

CABELA'S 65AT/H TOUR SERIES

65 lbs Thrust

24 Volt

48" Shaft

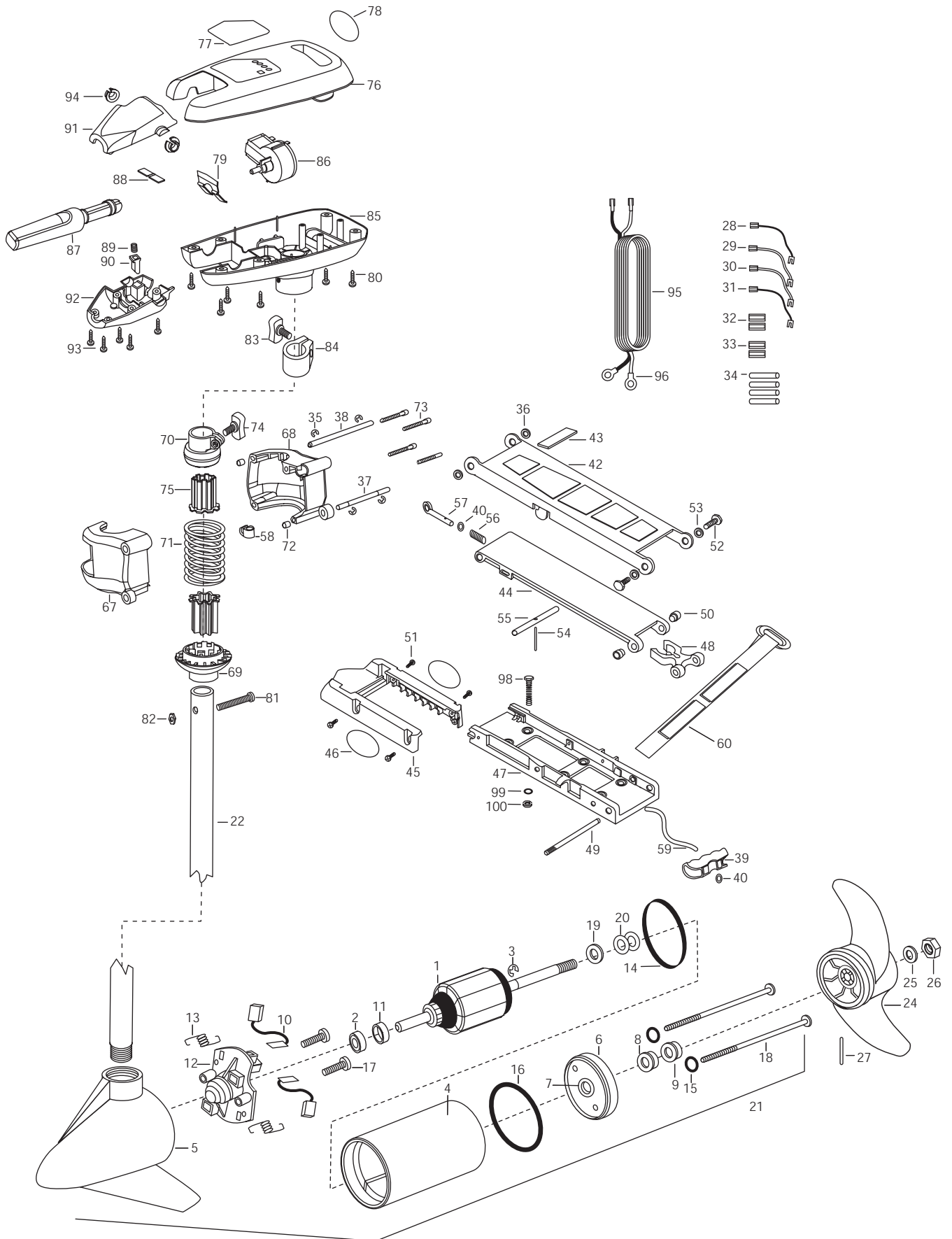

1	2-100-009	ARMATURE ASSEMBLY 24V 3.625 65#	35	2263010	E-RING 3/8 DIA SHAFT [4,EA]	74	2011365	SCREW-COLLAR/NEW KNOB
2	140-010	BEARING-BALL	36	2293500	BUSHING-SHOULDER UPR ARM [2.EA]	75	2264702	INSERT- TUBE 2PER
3	788-015	RETAINING RING	37	2260530	HINGE-PIN LOWER SS	76	2060290	COVER-CONTROL BOX GREY
4	431-005	CENTER HOUSING ASSEMBLY	38	2260520	HINGE-PIN UPPER SS	77	2265658	DECAL-COVER 65AT/H CABELA
5	2-300-039	BRUSH END HOUSING ASSEMBLY SPDCO	39	2150400	PULL-GRIP	78	2005601	DECAL- CABELA'S TOUR SERIES
6	2-400-101	PLAIN END HOUSING ASSEMBLY	40	2151700	WASHER-EYE SHAFT .562 OD [2.EA]	79	2302743	SPRING-DETENT HANDLE-TILT
7	144-049	BEARING- FLANGE SERVICE ONLY	■	2991872	BOW MOUNT ASSEMBLY 65AT	80	2303412	SCREW-6-20 X 5/8 SELF TAP [6.EA]
8	880-003	**SEAL	42	2264221	ARM-UPPER, STD, FW	81	2033400	SCREW-10-24 X 1-3/4]
9	880-006	**SEAL-W/SHIELD	43	2265120	BUMPER UPPER ARM	82	2013110	NUT-10-24 HEX (ZCP)
10	188-036	BRUSH ASSEMBLY [2.EA]	44	2254353	ARM-LWR AT FW MACH'D BG360	83	2011365	SCREW-COLLAR/NEW KNOB
11	725-050	TUBE- BRUSH RETENTION	45	2263900	MOTOR REST A/T	84	2031520	COLLAR-DEPTH W/O INSERT
12	738-036	BRUSH PLATE WITH HOLDER	46	2005601	DECAL- CABELA'S TOUR SERIES	85	2062551	CONTROL BOX PLAS W/HAND
13	975-040	SPRING- TORSION [2.EA]	47	2251922	BOW PLATE-MACHINED	86	2064023	SWITCH-FWD/REV 5SP
14	337-036	**GASKET	48	2293801	TUBE LOCK-'D'	87	2990912	HANDLE ASSEMBLY-W/U-JOINT 5SP
15	701-008	**O-RING THRU BOLT [2.EA]	49	2260506	HINGE-PIN (HEADLESS) ZINC [2.EA]	88	2302742	SPRING-DETENT OFF
16	701-081	**O-RING	50	2236000	BEARING NYLINER- [2.EA]	89	2302745	SPRING-RELEASE BUTTON
17	830-007	#8-32 SCREW [2.EA]	51	2303431	SCREW 1/4-20X5/8'PPH [4.EA]	90	2303720	RELEASE BUTTON-HANDLE
18	830-008	THRU BOLT 10-32X9.205 [2.EA]	52	2293511	BOLT-UPPER ARM W/LOCTITE [2.EA]	91	2060408	HANDLE- TOP HALF
19	990-067	WASHER- STEEL THRUST	53	2293500	BUSHING-SHOULDER UPR ARM [2.EA]	92	2060415	HANDLE- LOWER HALF
20	990-070	WASHER-NYLATRON [2.EA]	54	2152610	SPRING-PIN LOCKBAR	93	2303412	SCREW-6-20 X 5/8 SELF TAP [5.EA]
21	2098034	MOTOR ASSEMBLY 24V F/W 3.625 5SPCO	55	2233600	LOCK BAR- BOW MOUNT	94	2060005	BEARING-HANDLE PIVOT [2.EA]
22	2032054	TUBE- COMPOSITE-48"	56	2152700	SPRING- LOCKBAR CAD.PLTH	95	2090650	LEADWIRE -10 GA RINGS
■	1378122	PROPELLER KIT	57	2153600	EYE SHAFT-CAD.PLATE	96	2020700	TERMINAL RING, 3/8' [2.EA]
*24	2091150	PROPELLER- W/WEDGE	58	2262310	GUIDE-ROPE	■	2994838	BAG ASSEMBLY-BOLTS NUTS WASHERS
*25	2151726	WASHER- 5/16 SS	59	2251601	ROPE- 40"	*98	2263462	SCREW 1/4-20X2 SS [6.EA]
*26	2053101	NUT-PROP NYLOC MEDIUM	60	2263805	VELCRO STRAP	*99	2261713	WASHER-1/4 FLAT 18-18 [6.EA]
*27	2092600	PIN-DRIVE 95-4HP'S	■	2991873	BOWGUARD ASSEMBLY 65AT/H	*100	2263103	NUT- 1/4-20 NYLOC-JAM [6.EA]
28	2030312	WIRE EXTENSION 18"-16GA N	67	2261981	BRACKET BASE-LEFT			
29	2030313	WIRE EXTENSION 18"-18GA YEL	68	2261986	BRACKET BASE-RGHT			
30	2030316	WIRE EXTENSION 18"- BLK	69	2261535	SPRING SLEEVE LWR			
31	2030317	WIRE EXTENSION 18" - RED	70	2261525	SPRING-SLEEVE UPPER			
32	2030710	CONNECTOR BUTT [2.EA]	71	2262711	SPRING-BOWGUARD HAND CT			
33	2030711	CONNECTOR BUTT [2.EA]	72	2267300	BUSHING-DOWEL [2.EA]			
34	2375400	SHRINK TUBE 1/4ODX1-3/4 [4.EA]	73	2263470	SCREW-1/4-20 X 1-3/4 [4.EA]			

65AT/H Tournament Series Wiring Diagram

