

**MAXXUM 101**  
101 lbs Thrust  
36 Volt 37 Amps  
42" SHAFT

for use with motors with serial numbers beginning MKAE  
3-year warranty from the date of purchase

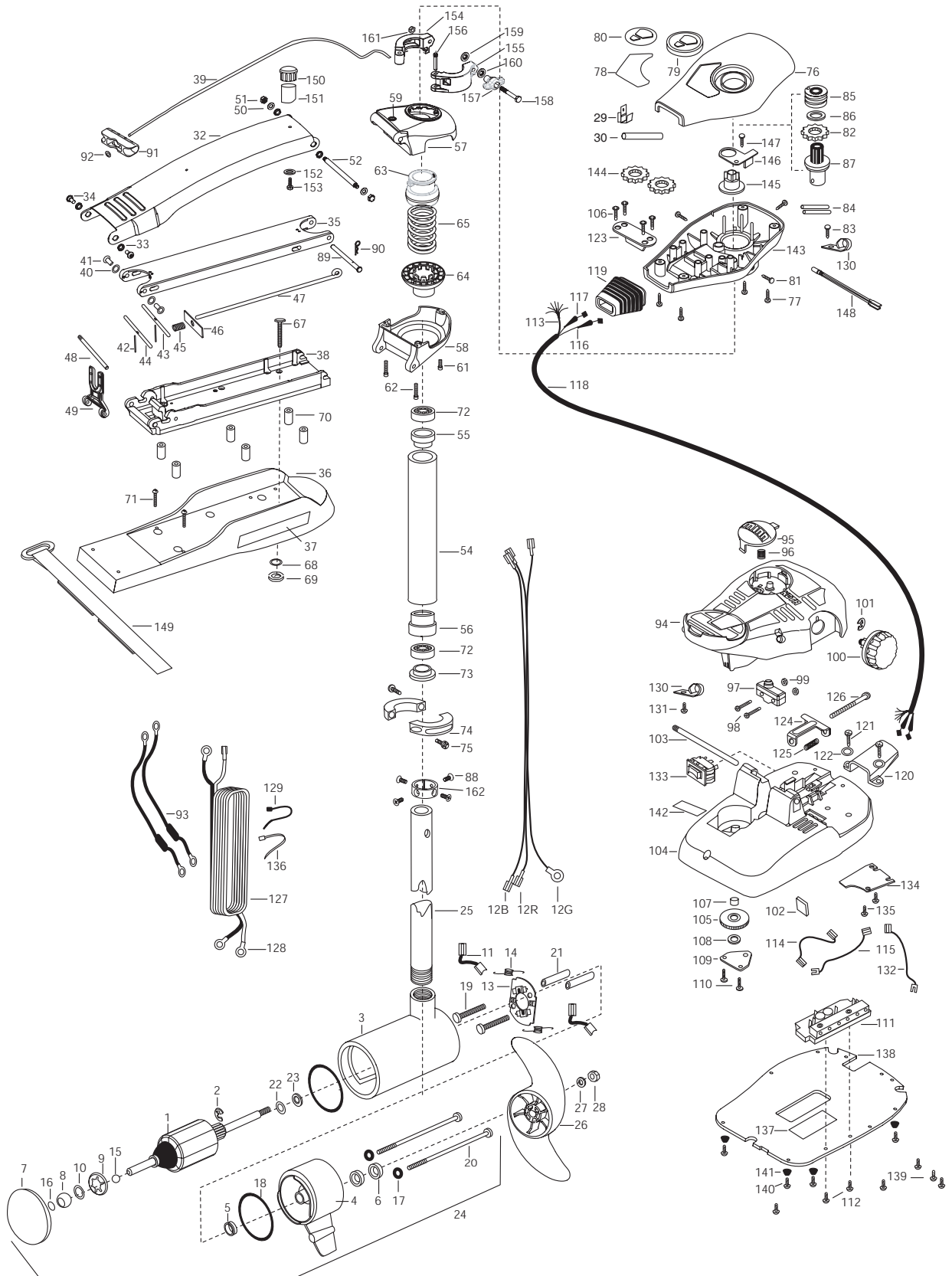

1	2-100-110	ARMATURE ASSEMBLY 36V 4 VARS TXT	54	2272069	TUBE OUTER -21" 4 HOLES	110	2301310	SCREW-8-18 X 1/2" SS [2.EA]
2	788-040	RETAINING RING	55	2266260	BEARING RACE- 565T	111	2264012	CONTROL BOARD ASSEMBLY- MAX101
3	431-110	CENTER HOUSING ASSEMBLY 4.0 FW TXT 101	56	2266220	BEARING RACE-STEEL	112	2053414	SCREW 8-32 X 1/2 TRI-LOBE [2.EA]
4	2-300-160	BRUSH END HOUSING ASSEMBLY 4.0 FW TXT	■	2991824	BOWGUARD ASSEMBLY-FT CT FW	113	2261218	WIRE HARNESS MAX 101
5	144-017	BEARING -FLANGE (SERVICE ONLY)	57	2772315	BRACKET BASE TOP/EYELET	114	2260325	WIRE,BLK W/GRN STRIPE 11 1/4"
6	880-025	**SEAL [2.EA]	58	2991993	BRACKET BOTTOM/BEARING ASSEMBLY	115	2260326	WIRE,RED W/YEL STRIPE 16 1/2"
7	2-400-160	PLAIN END HOUSING ASSEMBLY 4.0	59	2772352	EYELET KIT -ROPE	116	2267500	CABLE ASSEMBLY-RIGHT 5'
8	144-021	BEARING -SPHERICAL	61	2263402	SCREW 1/4-20 X 3/4" ZINC	117	2267510	CABLE ASSEMBLY-LEFT 5'
9	784-025	BEARING RETAINER	62	2263404	SCREW, 1/4-20 X 2-1/4" SHCP [2.EA]	118	2265430	CABLE JACKET 5'
10	991-040	FELT WASHER	63	2071541	SPRING-SLEEVE UPPER	119	2265110	BOOT-CONTROL BOX
11	186-094	BRUSH 4" [2.EA]	64	2071535	SPRING SLEEVE, LOWER	120	2265115	BOOT-FOOT PEDAL BASE
12B	640-014	BRUSH WIRE- BLACK 10 AWG 54 1/2	65	2262706	SPRING, BOWGUARD, NIK	121	2372100	SCREW-8-18 X 5/8",THDT [2.EA]
12R	640-118	BRUSH WIRE- RED 10 AWG 56 XLP	■	2994830	BAG ASSEMBLY-MAXXUM	122	2261714	WASHER-MAXXUM FT PDL [2.EA]
12G	640-302	GROUND WIRE- GREEN 10 AWG 54 1/2	*67	2263431	SCREW 1/4-20 X 3.5" PPH [6.EA]	123	2261901	BRACKET-CONDUIT AT/MAX
13	738-004	BRUSH PLATE - 4" TERMINAL	*68	2261713	WASHER-1/4" FLAT S/S [6.EA]	124	2263210	BRACKET-CONDUIT ADJUST
14	975-041	SPRING -TORSION [2.EA]	*69	2263103	NUT -NYLOCK JAM 1/4-20 S/S [6.EA]	125	2262720	SPRING-CONDUIT ADJUST
15	116-025	BALL-STEEL	70	2261505	SPACER, MOTOR REST [6.EA]	126	2263463	SCREW-1/4-20 X 2" STL PPH
16	303-043	THRUST DISC- METAL	71	2263434	SCREW, 8-18 X 1" PPH [2.EA]	127	2261227	LEADWIRE A/T VARIABLE
17	701-009	**O-RING -THRU BOLT [2.EA]	72	2266000	BEARING, BALL-STEEL [2.EA]	128	2020700	TERMINAL RING, 3/8" [2.EA]
18	701-043	**O-RING [2.EA]	73	2266115	BEARING CONE	129	2256300	TIE WRAP-5.5" BLACK
19	830-027	SCREW -SELF TREADED 10-32 X 2" [2.EA]	74	2261619	COLLAR HALF-ZINC-2 PER	130	2263201	CLAMP WIRE HARNESS MICRO [2.EA]
20	830-096	THRU BOLT 12-24 X 11.56" SS [2.EA]	75	2263452	SCREW- 1/4-20X3/4 SHCP SS [2.EA]	131	2332103	SCREW-6-20 X 3/8" THD
21	973-025	SPACER -BRUSH PLATE [2.EA]	76	2260283	CONTROL BOX COVER-MAX	132	2260312	WIRE,BLK W/WHT STRIPE 19 1/4"
22	990-051	WASHER-THRUST, STEEL	77	2372100	SCREW-8-18 X 5/8" THD SS [4.EA]	133	2254031	SWITCH-MOM/OFF/COM
23	990-052	WASHER- NYLATRON	78	2265539	DECAL COVER, MAXXUM 101	134	2266412	SWITCH PLATE, FT PEDAL
24	2317050	MOTOR ASSEMBLY 36V 4 VARS TXT	79	2260150	POINTER DISC TRNSLCNT	135	2332103	SCREW-6-20 X 3/8" THD [2.EA]
25	2032003	TUBE (COMP) W/CSK HOLE 43 3/4	80	2265800	DECAL-INDICATOR	136	2256301	TIE WRAP-5.5" WHITE [2.EA]
■	1378130	PROPELLER KIT (includes 26-28)	81	2053414	SCREW-8-32 X 1/2" TRI-LOBE [3.EA]	137	2365109	INSULATING PAD 2.4 X 4.7"
26	2331130	PROPELLER (W.WEDGE)	82	2267800	GEAR INDICATOR	138	2264511	BOTTOM PLATE, MAX 101
27	2091701	WASHER-PROP (LARGE) MAX 101	83	2301310	SCREW-8-18 X 1/2" SS	139	9953104	SCREW-8 X 1/2" SS [5.EA]
28	2093101	NUT-PROP (LARGE) MAX 101	84	2355410	SHRINK TUBE-3/8 OD X 2" [2.EA]	140	2263455	SCREW #12-14 X 1/2" THR FRM [4.EA]
29	2020713	TERMINAL- ADAPTOR MAX50/S	85	2232360	PULLEY-CABLE DRUM	141	2265126	BUMPER PAD, FOOT PEDAL [4.EA]
30	2335400	SHRINK TUBE 1/4ODX2"	86	2261730	WASHER-NYLON A/T	142	2266610	DECAL-ON/OFF SWITCH
■	2771840	MOUNT, BOW ASSEMBLY, FW STD MAX 101	87	2996247	TOP BEARING RACE /PINION DRIVE ASSEMBLY	143	2262535	CONTROL BOX-PLASTIC
32	2264241	ARM-UPPER FW STD	88	2223468	SCREW-8-32 X 7/16" ZINC PLATE [4.EA]	144	2267800	GEAR-INDICATOR [2.EA]
33	2293501	BUSHING, STAINLESS STEEL [4.EA]	89	2262607	PIN- CLEVIS ZN PL	145	2262220	INDICATOR-DRIVE
34	2263500	BOLT, SHOULDER [2.EA]	90	2260801	SPRING CLIP ZN PL	146	2261905	BRACKET/INDICATOR
35	2994307	ARM-LOWER ASSEMBLY, STD, FW EXT	91	2150400	PULL-GRIP	147	2301310	SCREW-8-18 X 1/2" SS
36	2263912	MOTOR REST STD, MAXXUM	92	2151700	WASHER-EYE SHAFT .562"	148	2264015	LIGHT/INDICATOR
37	2265514	DECAL- MOTOR REST [2.EA]	93	2998200	CIRCUIT BREAKER ASSEMBLY 36V-101 [2.EA]	149	2263802	STRAP- HOLD DOWN 30.5 VELCRO]
38	2773987	BOWPLATE/INSERT- STD FW	94	2790002	FOOT PEDAL/PLUG ASSEMBLY	■	2994833	BAG ASSEMBLY- MAXXUM STABILIZER
39	2251601	ROPE 40" MAXXUM	95	2263700	PUSH-BUTTON FOOT PEDAL	*150	2268400	SHAFT- SUPPORT
40	2261708	WASHER-3/8 X 1/2 X.010" SS [2.EA]	96	2302732	SPRING-LOWER PEDAL SS	*151	2268401	BUMPER- SHAFT
41	2236000	BEARING NYLINER [2.EA]	97	2264023	SWITCH-SEALED ASSEMBLY	*152	2263465	SCREW 1/4-10X1" HHD Z/P
42	2152610	SPRING-PIN (LOCKBAR) [2.EA]	98	2262114	SCREW-MOUNTING/SWITCH [2.EA]	*153	2261716	WASHER- CONICAL ID.28 SS
43	2233600	LOCK BAR- (BOW MOUNT)	■	2991550	NUT-SWITCH MOUNT [2.EA]	154	2071550	CLAMP COLLAR ASSEMBLY
44	2233602	LOCK BAR, REAR - ZINC	100	2260160	KNOB-SPEED CONTROL	155	2071555	CLAMP COLLAR "A"
45	2152700	SPRING -LOCKBAR	101	2263000	E-RING TRU-ARC#5133-43	156	2072621	CLAMP COLLAR "B"
46	2262703	SPRING STOP	102	2266413	TENSION SCREW PLATE FT	157	2070120	PIN-KNURLED
47	2153602	EYE SHAFT -2LOCKBAR STD PLTD	103	2260511	PIN-PIVOT A/T FT PDL	158	2073412	KNOB-CLAMP COLLAR
48	2260506	HINGE-PIN HEADLESS ZINC	104	2992102	FOOT PEDAL BASE/PIN ASSEMBLY	159	2071718	SCREW 1/4-28 X 2 3/4" SS
49	2293811	YOKE, MAXXUM MOUNT POLYPROPYLENE	105	2262300	PULLEY FOOT PEDAL	160	2071716	WASHER #10 NYLON RETAINING
50	2261722	WASHER SS [2.EA]	106	2223430	SCREW- #8 X3/4" PPH TYPE 25 SS [4.EA]	161	2073102	WASHER - FLAT SS
51	2263100	NUT- TENSION 5/16-18 SS [2.EA]	107	2260000	BEARING-PULLEY	162	2071560	NUT - HEX 1/4 - 28 SS
52	2262605	PIN- BWGRD UPPER THREADED ZP	108	2261705	WASHER-NYLATRON A/T			SPLIT COLLAR
■	2772012	TUBE W/BEARING RACE ASSEMBLY	109	2266400	COVER-PULLEY STAMPING			

\*\* Seal & Oring Kit P/N 2889460

\* This item is part of an assembly. This item cannot be sold separately due to machining and /or assembly that is required.

P/N 2264933 REV.E

7-01

