

MAXXUM 55/H/SC- 3X STEERING
BOWGUARD 360°® MOUNT
55 LBS THRUST
12 VOLT 45 AMPS
52" SHAFT

for use with motors with serial numbers beginning MKAE
3-year warranty from the date of purchase

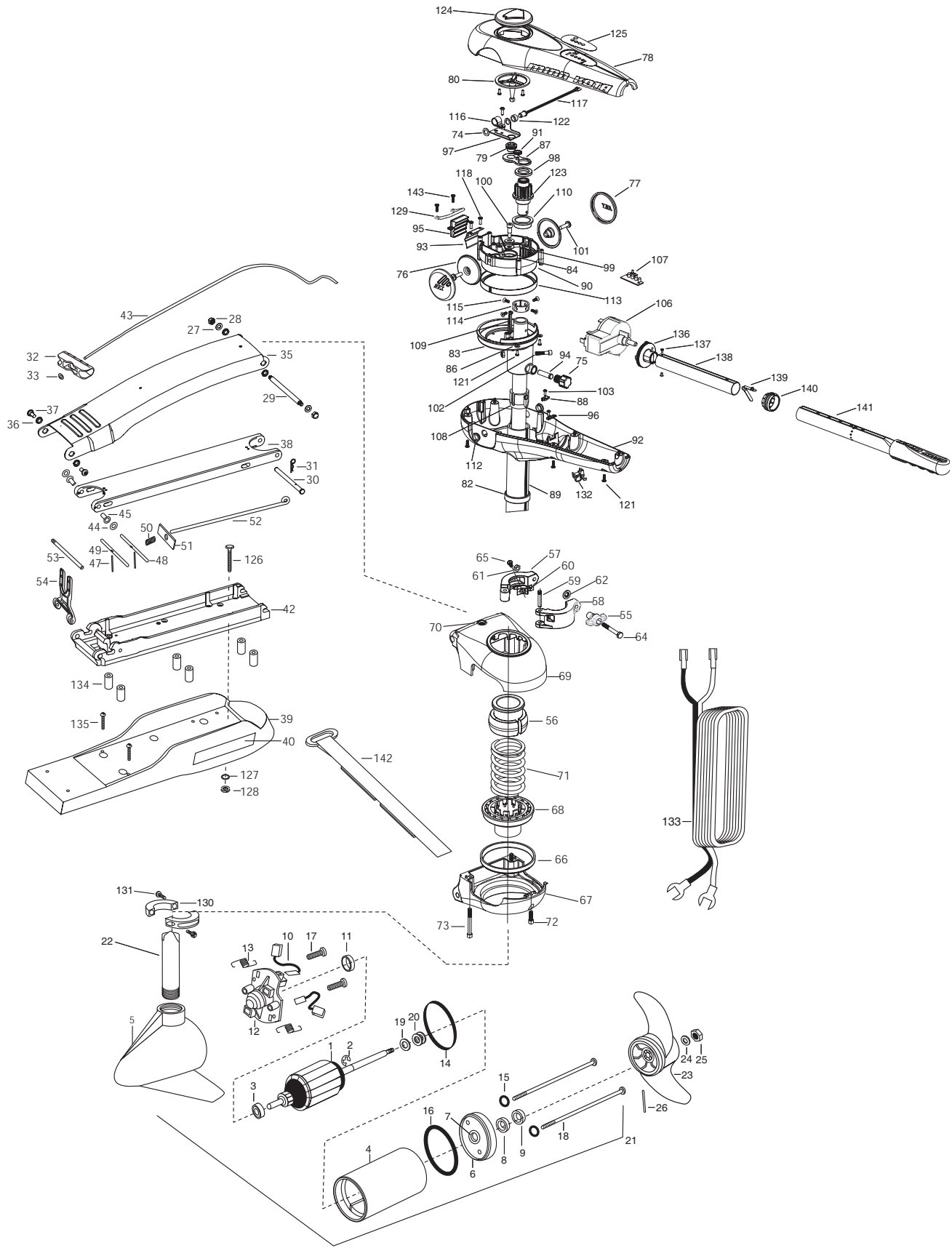

1	2-100-013	ARMATURE ASSEMBLY 12V 3.625 5SPC 55#	48	2233620	LOCK BAR- BOW MOUNT	97	2072900	RETAINER COUPLER
2	788-015	RETAINING RING	49	2233622	LOCK BAR, REAR - ZINC	98	2073000	RING PRELOAD
3	140-010	BALL BEARING	50	2152700	SPRING-LOCKBAR CAD.PLTD	99	2073100	HEX NUT - NYLOC [2 EA.]
4	2-200-101	CENTER HOUSING ASSEMBLY 3.625 FW TXT	51	2262703	SPRING STOP	100	2073400	SCREW 5/16" X 1/2" SHOULDER
5	2-300-200	BRUSH END HOUSING ASSEMBLY 3.62 SPCO	52	2153602	EYE SHAFT-2LOCKBAR STD-PL	101	2073408	SCREW [2 EA.]
6	2-400-101	PLAIN END HOUSING ASSEMBLY	53	2260506	HINGE-PIN HEADLESS ZINC	102	2073410	SCREW
7	144-049	BEARING - FLANGE (SERVICE ONLY)	54	2293811	YOKE,MAX MNT-POLYPROPYLENE	106	2064023	SWITCH 5 SPD FOR / REV
8	880-003	**SEAL	55	2070120	KNOB CLAMP COLLAR	107	2074070	BATTERY METER
9	880-006	**SEAL WITH SHIELD	56	2071541	SPRING SLEEVE UPPER	108	2075100	TENSION SLEEVE
10	188-036	BRUSH ASSEMBLY [2.EA]	■	2991555	COLLAR/CLAMP ASSEMBLY	109	2076700	KEY - TUBE
11	725-050	BRUSH RETENTION- PAPER TUBE	57	2071550	COLLAR CLAMP "A"	110	2077305	BEARING UPPER
12	738-036	BRUSH PLATE W/HOLDER	58	2071555	COLLAR CLAMP "B"	112	2077316	BUSHING [2 EA.]
13	975-040	SPRING - TORSION [2.EA]	59	2072621	PIN KNURLED	113	2077320	BEARING - GEAR CARRIER
14	337-036	**GASKET	60	2072821	ORIENTATION BLOCK	114	2071560	COLLAR TUBE
15	701-008	**O-RING, THRU-BOLT [2.EA]	61	2073100	NUT - NYLOC	115	2223468	SCREW 8-32 [4 EA.]
16	701-081	**O-RING	62	2071718	WASHER #10 NYLOK	116	2263201	CLAMP WIRE HARNESS
17	830-007	SCREW-8-32 [2.EA]	64	2073412	SCREW 1/4 - 20"HHC	117	2264015	LIGHT INDICATOR
18	830-042	THRU-BOLT 10-32X8.83" [2.EA]	65	2223454	SCREW 10-32 SS	118	2372100	SCREW 8-18 SS [2 EA.]
19	990-067	WASHER- STEEL THRUST	■	2991893	BOWGUARD ASSEMBLY	X	X	
20	990-070	WASHER - NYLATRON [2.EA]	■	2991999	BRACKET/BEARING ASSEMBLY	121	2303412	SCREW 6-20 X 5/8" [8 EA.]
21	2099102	MOTOR ASSEMBLY 12V 3.62 5 SPD F/W	*66	2261534	BEARING	122	2071525	SPACER-INDICATOR LIGHT
22	2072006	TUBE- COMPOSITE 3:1 52"	*67	2262045	BRACKET BASE BOTTOM	123	2992205	PINION - MAIN
■	1378122	PROPELLER KIT (includes 23-26)	68	2261535	SPRING SLEEVE LOWER	124	2998600	INDICATOR ASSEMBLY
23	2091150	PROPELLER W/WEDGE	69	2261971	BRACKET BASE TOP	125	2075620	DECAL COVER MAX 55 W/3X
24	2151726	WASHER-5/16 SS	70	2262315	EYELET ROPE	■	2994830	BAG ASSEMBLY - MAXXUM VECTOR
25	2053101	NUT-PROP NYLOC	71	2262712	SPRING BOWGUARD	*126	2263431	1/4-20X3.5" PPH [6.EA]
26	2092600	PIN-DRIVE	72	2263402	SCREW 1/4 - 20" ZINC	*127	2261713	WASHER 1/4 FLAT SS [6.EA]
27	2261722	WASHER FLAT [2.EA]	73	2263404	SCREW 1/4 - 20" SHCP SS [2 EA.]	*128	2263103	NUT 1/4-20 NYLOC-JAM SS [6.EA]
28	2223100	NUT- TENSION 5/16-18 SS [2 .EA]	74	2013100	SPEED NUT	129	2072815	BRACKET-TILT STOP
29	2262605	PIN- BWGRD UPPER THREADED	75	2070105	KNOB-TENSION	130	2261622	COLLAR HALF [2 EA.]
30	2262607	CLEVIS PIN ZP MAXXUM BWGRD	76	2070110	PIVOT KNOB [2 EA.]	131	2263453	SCREW 1/4-20 X 1" [2 EA.]
31	2260801	SPRING CLIP	77	2070117	COVER-PIVOT KNOB [2 EA.]	132	2052900	STRAIN RELIEF
32	2150400	PULL-GRIP	78	2070201	COVER 3:1	133	2090650	LEADWIRE
33	2151700	WASHER-EYE SHAFT(.562 OD)	79	2070800	COUPLER SOCKET	■	2994832	BAG ASSEMBLY-MAXXUM VECTOR
■	2991854	MOUNT, BOW ASSEMBLY	80	2070810	COUPLER DRIVE	*134	2261505	SPACER, MOTOR REST [6.EA]
35	2264241	ARM-UPPER FW,STD.	82	2071500	COLLAR LOWER SUPPORT	*135	2263434	SCREW, 8-18 X 1" PPH SS [2.EA]
36	2293501	BUSHING, STAINLESS STEEL [4.EA]	83	2071512	YOKE-GEAR CARRIER	136	2070406	PIVOT-HANDLE
37	2263500	BOLT- SHOULDER (MAXXUM) [2.EA]	84	2071710	WASHER NYLATRON [2 EA.]	137	2072102	SCREW #6 X 1/4" [2 EA.]
38	2994307	ARM-LOWER ASSEMBLY,STD,FW,EXT	85	2071712	WASHER SS	138	2070425	HANDLE TUBE
39	2263912	MOTOR REST STD MAXXUM	86	2071714	WASHER FLAT #6 [2 EA.]	139	2070411	LATCH-BUTTON
40	2265514	DECAL-MAXXUM,MOTOR REST [2.EA]	87	2071900	IDLER PLATE	140	2070010	BEARING
41	2261505	SPACER, MOTOR REST [6.EA]	89	2072080	OUTER TUBE 3:1 52"	141	2990935	HANDLE ASSEMBLY-EXT.
42	2993987	BOWPLATE,STD. FW-MACH/INSERT	90	2072210	GEAR CARRIER	142	2263804	STRAP-HOLD DOWN
43	2251601	ROPE (40"), MAXXUM MOUNT	91	2072215	GEAR- IDLER	143	2332101	SCREW #8-32 X 1/2" SS [2 EA.]
44	2261707	WASHER-3/8X1/2X.010" SS [2.EA]	92	2072501	CONTROL BOX			
45	2236000	BEARING NYLINER-[2.EA]	93	2072705	SPRING DETENT			
46	2263434	SCREW, 8-18 X 1" PPH SS [2.EA]	94	2072710	SPRING TENSION SLEEVE			
47	2152612	SPRING-PIN LOCKBAR [2.EA]	95	2072810	DETENT BLOCK-TILT			

**Seal & Oring Kit P/N 2888460

* This item is part of an assembly. This item cannot be sold separately due to machining and /or assembly that is required.

P/N 2074910

REV.A 7-03

