

MAXXUM 65/H - 3X STEERING
BOWGUARD 360° MOUNT
65 LBS THRUST
24 VOLT 38 AMPS
52" SHAFT

for use with motors with serial numbers beginning MKAE
3-year warranty from the date of purchase

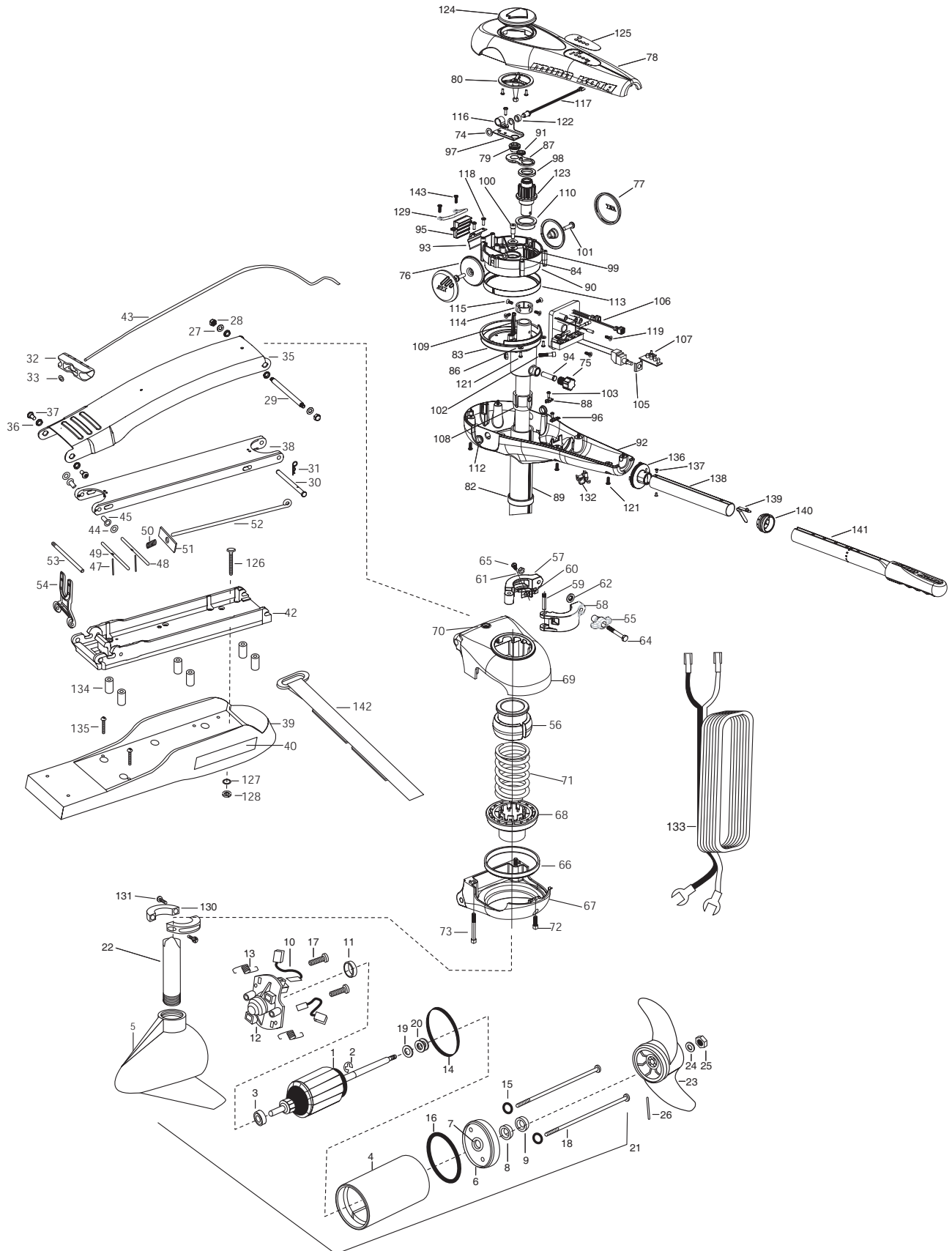

1	2-100-009	ARMATURE ASSEMBLY	49	2263622	LOCK BAR, REAR - ZINC	96	2072811	DETENT BLOCK-SWITCH
2	140-010	BALL BEARING	50	2152700	SPRING-LOCKBAR CAD.PLTD	97	2072900	RETAINER COUPLER
3	788-015	RETAINING RING	51	2262703	SPRING STOP	98	2073000	RING PRELOAD
4	2-200-005	HOUSING ASSEMBLY CENTER 3.62 TXT	52	2153602	EYE SHAFT-2LOCKBAR STD-PL	99	2073100	NUT - NYLOC
5	421-065	HOUSING -BRUSH END 3.62 TXT	53	2260506	HINGE-PIN HEADLESS ZINC	100	2073400	SCREW 5/16" X 1/2" SHOULDER
6	2-400-101	PLAIN END HOUSING ASSEMBLY 3.625	54	2293811	YOKE,MAX MNT-POLYPROPYLENE	101	2073408	SCREW [2 EA.]
7	144-049	BEARING - FLANGE (SERVICE ONLY)	55	2070120	KNOB CLAMP COLLAR	102	2073410	SCREW
8	880-003	**SEAL	56	2071541	SPRING SLEEVE UPPER	103	2073414	SCREW 6-32 PPH [2 EA.]
9	880-006	**SEAL WITH SHIELD	■	2991555	COLLAR/CLAMP ASSEMBLY	105	2074000	POT CLIP
10	188-036	BRUSH ASSEMBLY [2.EA]	57	2071550	COLLAR CLAMP "A"	106	2074061	CONTROL BOARD ASSEMBLY
11	725-050	BRUSH RETENTION- PAPER TUBE	58	2071555	COLLAR CLAMP "B"	107	2074071	BATTERY METER
12	738-036	BRUSH PLATE W/HOLDER	59	2072621	PIN KNURLED	108	2075100	TENSION SLEEVE
13	975-040	SPRING - TORSION [2.EA]	60	2072821	ORIENTATION BLOCK	109	2076700	KEY - TUBE
14	337-036	**GASKET	61	2073100	HEX NUT - NYLOC	110	2077305	BEARING UPPER
15	701-008	**O-RING, THRU-BOLT [2.EA]	62	2071718	WASHER-#10 NYLON	112	2077316	BUSHING [2 EA.]
16	701-081	**O-RING	64	2073412	SCREW 1/4 - 20"HHC	113	2077320	BEARING - GEAR CARRIER
17	830-007	SCREW-8-32 [2.EA]	65	2223454	SCREW 10-32 SS	114	2071560	COLLAR TUBE
18	830-008	THRU-BOLT 10-32X8.83 [2.EA]	■	2991893	BOWGUARD ASSEMBLY	115	2223468	SCREW 8-32 [4 EA.]
19	990-067	WASHER- STEEL THRUST	■	2991999	BRACKET/BEARING ASSEMBLY	116	2263201	CLAMP WIRE HARNESS
20	990-070	WASHER - NYLATRON [2.EA]	*66	2261534	BEARING	117	2264015	LIGHT INDICATOR
21	2098032	MOTOR ASSEMBLY 12V 3.62 VARS F/W	*67	2262045	BRACKET BASE BOTTOM	118	2372100	SCREW 8-18 SS [2 EA.]
22	2072006	TUBE- COMPOSITE 3:1 52"	68	2261535	SPRING SLEEVE LOWER	119	2332101	SCREW 8-32 SS [4 EA.]
■	1378122	PROPELLER KIT (includes 23-26)	69	2261971	BRACKET BASE TOP	X	X	
23	2091150	PROPELLER W/WEDGE	70	2262315	EYELET ROPE	121	2303412	SCREW 6-20 X 5/8" [8 EA.]
24	2151726	WASHER-5/16 SS	71	2262712	SPRING BOWGUARD	122	2071525	SPACER-LIGHT INDICATOR
25	2053101	NUT-PROP NYLOC	72	2263402	SCREW 1/4 - 20" ZINC	123	2992205	PINION - MAIN
26	2092600	PIN-DRIVE	73	2263404	SCREW 1/4 - 20" SHCP SS [2 EA.]	124	2998600	INDICATOR ASSEMBLY
27	2261722	WASHER FLAT [2.EA]	74	2013100	SPEED NUT	125	2075621	DECAL MAX 65 W/3X
28	2223100	NUT- TENSION 5/16-18 SS [2 .EA]	75	2070105	KNOB-TENSION	■	2994830	BAG ASSEMBLY - MAXXUM VECTOR
29	2262605	PIN- BWGRD UPPER THREADED	76	2070110	PIVOT KNOB [2 EA.]	*126	2263431	1/4-20X3.5" PPH [6.EA]
30	2262607	CLEVIS PIN ZP MAXXUM BWGRD	77	2070117	COVER-PIVOT KNOB [2 EA.]	*127	2261713	WASHER 1/4 FLAT SS [6.EA]
31	2260801	SPRING CLIP	78	2070201	COVER 3:1	*128	2263103	NUT 1/4-20 NYLOC-JAM SS [6.EA]
32	2150400	PULL-GRIP	79	2070800	COUPLER SOCKET	129	2072815	BRACKET-TILT STOP
33	2151700	WASHER-EYE SHAFT(.562 OD)	80	2070810	COUPLER DRIVE	130	2261622	COLLAR HALF [2 EA.]
■	2991854	MOUNT, BOW ASSEMBLY STD.	82	2071500	COLLAR-LOWER SUPPORT	131	2263453	SCREW 1/4-20 X 1" [2 EA.]
■	2771866	STD. MOUNT	83	2071512	YOKE-PIVOT	132	2052900	STRAIN RELIEF
35	2264241	ARM-UPPER FW,STD.	84	2071710	WASHER NYLATRON [2 EA.]	133	2090650	LEADWIRE
36	2293501	BUSHING, STAINLESS STEEL [4.EA]	85	2071712	WASHER SS	■	2994832	BAG ASSEMBLY-MAXXUM VECTOR
37	2263500	BOLT- SHOULDER (MAXXUM) [2.EA]	86	2071714	WASHER FLAT #6 [2 EA.]	*134	2261505	SPACER, MOTOR REST [6.EA]
38	2994307	ARM-LOWER ASSEMBLY,STD,FW,EXT	87	2071900	IDLER PLATE	*135	2263434	SCREW, 8-18 X 1" PPH SS [2.EA]
39	2263912	MOTOR REST,STD. MAXXUM	88	2071905	BRACKET- SENSOR SWITCH	136	2990404	PIVOT HANDLE ASSEMBLY
40	2265514	DECAL-MAXXUM,MOTOR REST [2.EA]	89	2072080	OUTER TUBE 3:1 52"	137	2072102	SCREW #6 X 1/4" [2 EA.]
42	2993987	BOWPLATE,STD. FW-MACH/INSERT	90	2072210	GEAR CARRIER	138	2070425	TUBE-HANDLE
43	2251601	ROPE (40"), MAXXUM MOUNT	91	2072215	GEAR- IDLER	139	2070411	LATCH-BUTTON
44	2261707	WASHER-3/8X1/2X.010" SS [2.EA]	92	2072501	CONTROL BOX	140	2070010	BEARING
45	2236000	BEARING NYLINER-[2.EA]	93	2072705	SPRING DETENT	141	2990930	HANDLE ASSEMBLY-EXT.
47	2152612	SPRING-PIN LOCKBAR [2.EA]	94	2072710	SPRING TENSION SLEEVE	142	2263804	STRAP-HOLD DOWN
48	2263620	LOCK BAR- BOW MOUNT	95	2072810	DETENT BLOCK-TILT	143	2332101	SCREW #8-32 X1/2" SS [2EA.]

**Seal & Oring Kit P/N 2888460 * This item is part of an assembly. This item cannot be sold separately due to machining and /or assembly that is required.

P/N 2074911

REV.A 7-03

