

MAXXUM 70/H - 3X STEERING
BOWGUARD 360° MOUNT
70 LBS THRUST
24 VOLT 42 AMPS
52" SHAFT

for use with "WWAF" serial numbers
3-year warranty from the date of purchase

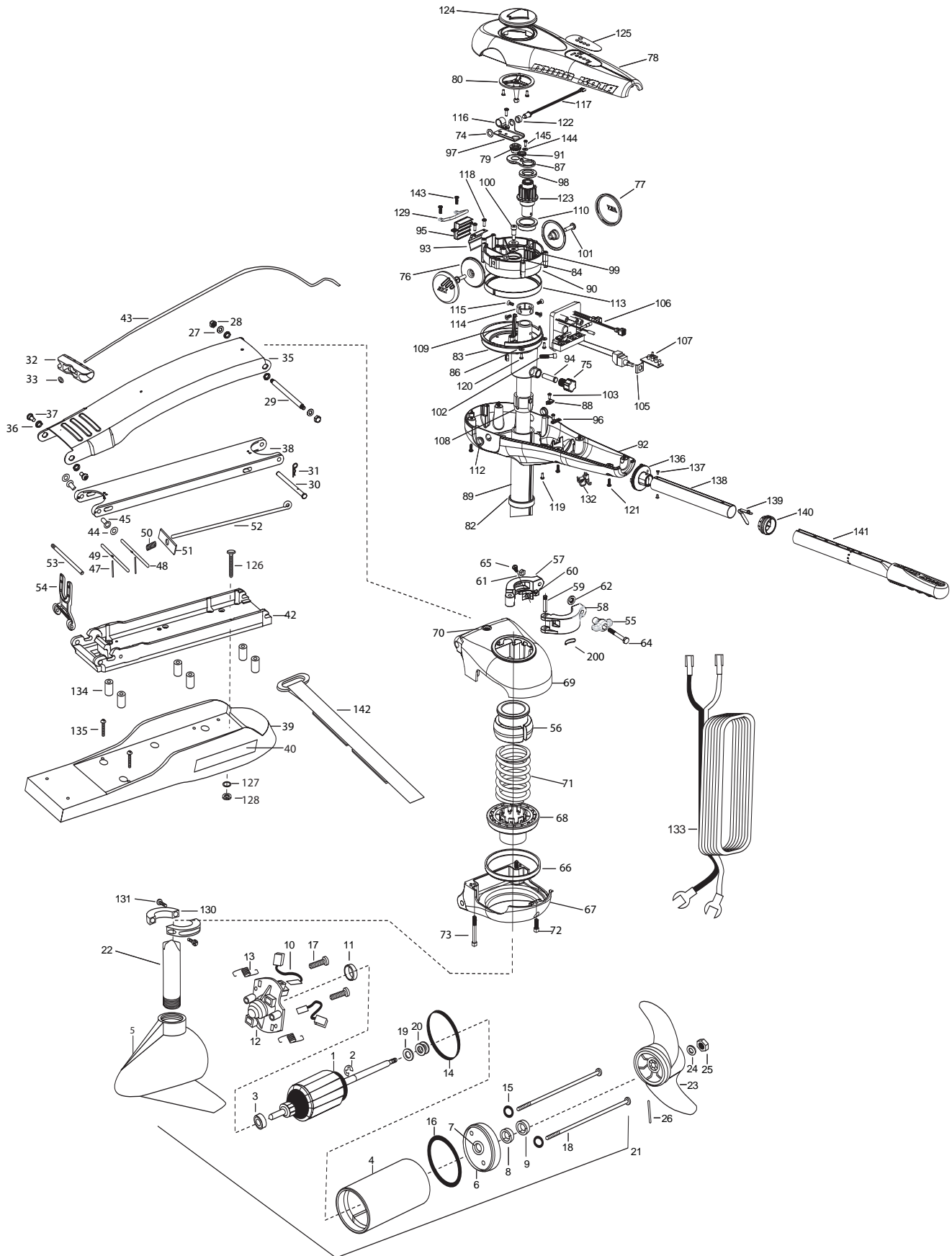

1	92-100-119	ARMATURE ASSEMBLY	50	2152700	SPRING-LOCKBAR CAD.PLTD	98	2073000	RING PRELOAD
2	140-010	BALL BEARING	51	2262703	SPRING STOP	99	2073100	NUT - NYLOC
3	788-015	RETAINING RING	52	2153602	EYE SHAFT-2LOCKBAR STD-PL	100	2073400	SCREW 5/16" X 1/2" SHOULDER
4	2-200-005	HOUSING ASSEMBLY CENTER 3.62 TXT	53	2260506	HINGE-PIN HEADLESS ZINC	101	2073408	SCREW [2 EA.]
5	421-065	HOUSING -BRUSH END 3.62 TXT	54	2293811	YOKE,MAX MNT-POLYPROPYLENE	102	2073410	SCREW
6	2-400-101	PLAIN END HOUSING ASSEMBLY 3.625	55	2070120	KNOB CLAMP COLLAR	103	2073414	SCREW 6-32 PPH [2 EA.]
7	144-049	BEARING - FLANGE (SERVICE ONLY)	56	2071541	SPRING SLEEVE UPPER	105	2074000	POT CLIP
8	880-003	SEAL	■	2991555	COLLAR/CLAMP ASSEMBLY	106	2074061	CONTROL BOARD ASSEMBLY
9	880-006	SEAL WITH SHIELD	57	2071550	COLLAR CLAMP "A"	107	2074071	BATTERY METER
10	188-036	BRUSH ASSEMBLY [2.EA]	58	2071555	COLLAR CLAMP "B"	108	2075100	TENSION SLEEVE
11	725-050	BRUSH RETENTION- PAPER TUBE	59	2072621	PIN KNURLED	109	2076701	KEY - TUBE
12	738-036	BRUSH PLATE W/HOLDER	60	2072821	ORIENTATION BLOCK	110	2077305	BEARING UPPER
13	975-040	SPRING - TORSION [2.EA]	61	2073102	HEX NUT	112	2077316	BUSHING [2 EA.]
14	337-036	GASKET	62	2071718	WASHER-#10 NYLON	113	2077320	BEARING - GEAR CARRIER
15	701-008	O-RING, THRU-BOLT [2.EA]	64	2073412	SCREW 1/4 - 28"HHC	114	2071560	COLLAR TUBE
16	701-081	O-RING	65	2073418	SCREW 10-32 SS	115	2223468	SCREW 8-32 [4 EA.]
17	830-007	SCREW-8-32 [2.EA]	■	2991762	BOWGUARD ASSEMBLY	116	2263201	CLAMP WIRE HARNESS
18	830-008	THRU-BOLT 10-32X8.83 [2.EA]	■	2991771	BRACKET/BEARING ASSEMBLY	117	2264015	LIGHT INDICATOR
19	990-067	WASHER- STEEL THRUST	*66	2261534	BEARING	118	2372100	SCREW 8-18 SS [2 EA.]
20	990-070	WASHER - NYLATRON [2.EA]	*67	2262050	BRACKET BASE BOTTOM	119	2073416	SCREW 8-32 SS SHCS [2 EA.]
21	2096032	MOTOR ASSEMBLY 12V 3.62 VARS F/W	68	2261535	SPRING SLEEVE LOWER	120	2304012	SCREW 6-20 [2 EA.]
22	2072006	TUBE- COMPOSITE 3:1 52"	69	2772319	BRACKET BASE TOP W/ WYELET	121	2304012	SCREW 8-18 X 5/8" [6 EA.]
■	1378131	PROPELLER KIT	70	2262315	EYELET ROPE	122	2071525	SPACER-LIGHT INDICATOR
23	2091160	PROPELLER W/WEDGE 2	71	2262712	SPRING BOWGUARD	123	2992205	PINION - MAIN
24	2151726	WASHER-5/16 SS	72	2263423	SCREW 5/16-18 X 1" SHCS ZINC	124	2998600	INDICATOR ASSEMBLY
25	2053101	NUT-PROP NYLOC	73	2263425	SCREW 5/16-18 X 2-1/2" SHCS [2 EA.]	125	2075624	DECAL MAX 70 W/3X
26	2092600	PIN-DRIVE	74	2013100	SPEED NUT	■	2994830	BAG ASSEMBLY - MAXXUM VECTOR
27	2261722	WASHER FLAT [2.EA]	75	2070105	KNOB-TENSION	*126	2263431	1/4-20X3.5" PPH [6.EA]
28	2223100	NUT- TENSION 5/16-18 SS [2 .EA]	76	2070110	PIVOT KNOB [2 EA.]	*127	2261713	WASHER 1/4 FLAT SS [6.EA]
29	2262605	PIN- BWGRD UPPER THREADED	77	2070117	COVER-PIVOT KNOB [2 EA.]	*128	2263103	NUT 1/4-20 NYLOC-JAM SS [6.EA]
30	2262607	CLEVIS PIN ZP MAXXUM BWGRD	78	2070201	COVER 3:1	129	2072815	BRACKET-TILT STOP
31	2260801	SPRING CLIP	79	2070800	COUPLER SOCKET	130	2261622	COLLAR HALF [2 EA.]
32	2150400	PULL-GRIP	80	2070810	COUPLER DRIVE	131	2263453	SCREW 1/4-20 X 1" [2 EA.]
33	2151700	WASHER-EYE SHAFT,(562 OD)	82	2071500	COLLAR-LOWER SUPPORT	132	2052900	STRAIN RELIEF
■	2991854	MOUNT, BOW ASSEMBLY STD.	83	2071512	YOKE-PIVOT	133	2090650	LEADWIRE
■	2771866	STD. MOUNT	84	2071710	WASHER NYLATRON [2 EA.]	■	2994832	BAG ASSEMBLY-MAXXUM VECTOR
35	2264241	ARM-UPPER FW,STD.	85	2071712	WASHER SS	*134	2261505	SPACER, MOTOR REST [6.EA]
36	2293501	BUSHING, STAINLESS STEEL [4.EA]	86	2071714	WASHER FLAT #6 [2 EA.]	*135	2263434	SCREW, 8-18 X 1" PPH SS [2.EA]
37	2263500	BOLT- SHOULDER (MAXXUM) [2.EA]	87	2071900	IDLER PLATE	136	2990404	PIVOT HANDLE ASSEMBLY
38	2994307	ARM-LOWER ASSEMBLY,STD.,FW,EXT	88	2071905	BRACKET- SENSOR SWITCH	137	2072102	SCREW #6 X 1/4" [2 EA.]
39	2263912	MOTOR REST,STD. MAXXUM	89	2072080	OUTER TUBE 3:1 52"	138	2070425	TUBE-HANDLE
40	2265514	DECAL-MAXXUM,MOTOR REST [2.EA]	90	2072210	GEAR CARRIER	139	2070411	LATCH-BUTTON
42	2993987	BOWPLATE,STD. FW-MACH/INSERT	91	2072215	GEAR- IDLER	140	2070010	BEARING
43	2251601	ROPE (40"), MAXXUM MOUNT	92	2072501	CONTROL BOX	141	2990930	HANDLE ASSEMBLY-EXT.
44	2261707	WASHER-3/8X1/2X.010" SS [2.EA]	93	2072705	SPRING DETENT	142	2263804	STRAP-HOLD DOWN
45	2236000	BEARING NYLINER-[2.EA]	94	2072710	SPRING TENSION SLEEVE	143	2332101	SCREW #8-32 X1/2" SS [2EA.]
47	2152612	SPRING-PIN LOCKBAR [2.EA]	95	2072810	DETENT BLOCK-TILT	144	2071720	#4 WASHER SS
48	2263620	LOCK BAR- BOW MOUNT	96	2072811	DETENT BLOCK-SWITCH	145	2373440	#4 SCREW SS
49	2263622	LOCK BAR, REAR - ZINC	97	2072900	RETAINER COUPLER	200	2075120	URETHANE PAD

