

RT80/B/H - 3X STEERING
BOWGUARD 360° MOUNT
80 LBS THRUST
24 VOLT 56 AMPS
52" SHAFT

for use with "WWAF" serial numbers
 3-year warranty from the date of purchase

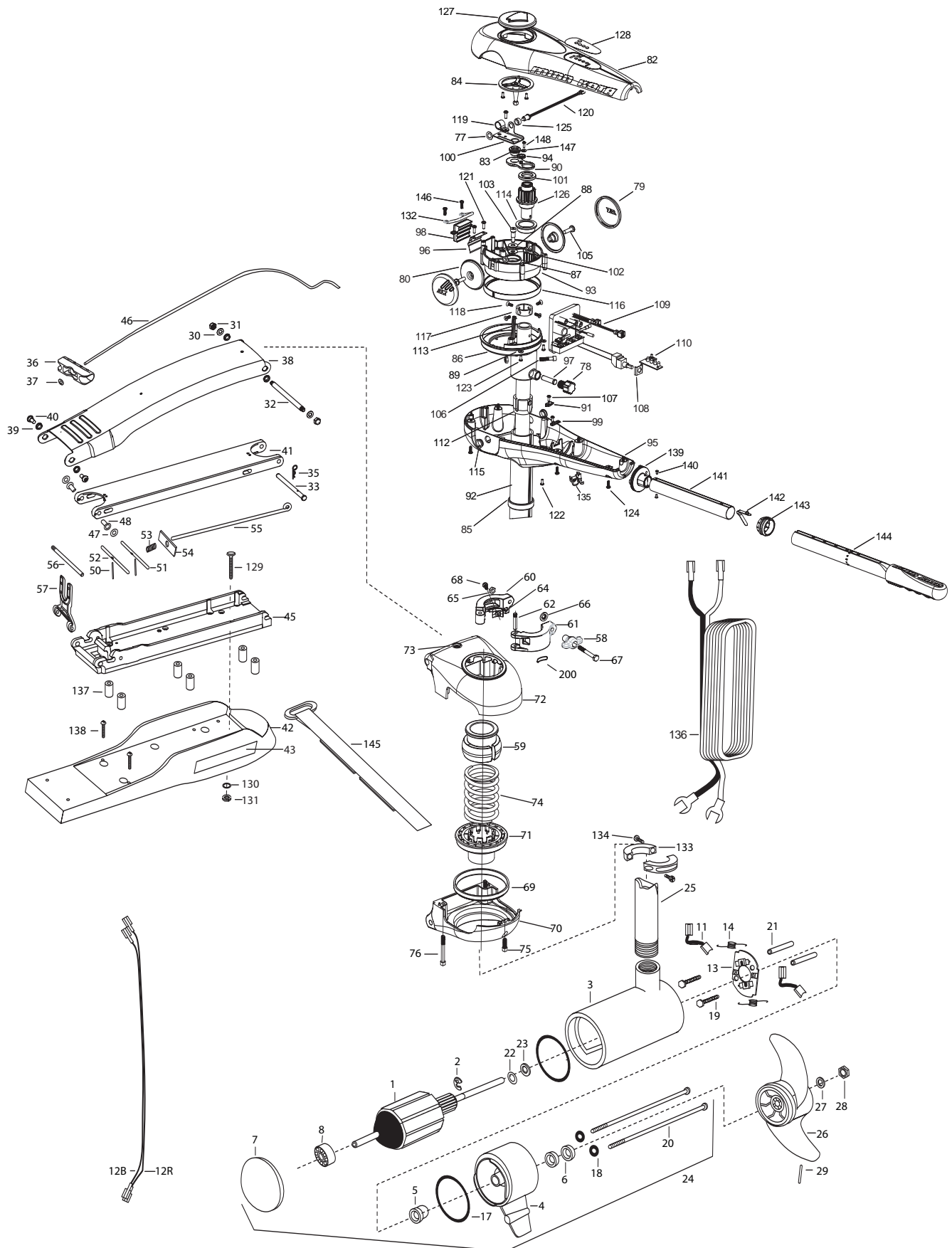

1	2-100-213	ARMATURE ASSEMBLY 24V 4"	54	2262703	SPRING STOP	102	2073100	HEX NUT - NYLOC
2	788-040	RETAINING RING	55	2153603	EYE SHAFT-2LOCKBAR-SS	103	2073400	SCREW 5/16" X 1/2" SHOULDER
3	2-200-397	CENTER HOUSING ASSEMBLY 4.0 TXT	56	2260505	HINGE-PIN HEADLESS-SS	105	2073408	SCREW [2 EA.]
4	2-300-340	BRUSH END HOUSING ASSEMBLY	57	2293811	YOKE,MAX MNT-POLYPROPYLENE	106	2073410	SCREW
5	144-017	BEARING- FLANGE (SERVICE ONLY)	■	2991765	BOWGUARD ASSEMBLY	107	2073414	SCREW 6-32 PPH [2 EA.]
6	880-025	SEAL [2.EA]	58	2070120	KNOB CLAMP COLLAR	108	2074000	POT CLIP
7	421-360	PLAIN END HOUSING ASSEMBLY	59	2071541	SPRING SLEEVE-UPPER	109	2074061	CONTROL BOARD ASSEMBLY
8	140-010	BALL BEARING	■	2991555	COLLAR/CLAMP ASSEMBLY	110	2074081	BATTERY METER
11	186-094	BRUSH [2.EA]	60	2071550	COLLAR CLAMP "A"	112	2075100	TENSION SLEEVE
12B	640-021	LEADWIRE-BLACK 10 AWG 68 1/2" (52")	61	2071555	COLLAR CLAMP "B"	113	2076701	KEY - TUBE
12R	640-126	LEADWIRE-RED 10 AWG 74" (52")	62	2072621	PIN KNURLED	114	2077305	BEARING UPPER
13	738-004	BRUSH PLATE 4"	64	2072821	ORIENTATION BLOCK	115	2077316	BUSHING-PIVOT [2 EA.]
14	975-041	SPRING- TORSION [2.EA]	65	2073102	NUT	116	2077320	BEARING - GEAR CARRIER
17	701-043	O-RING [2.EA]	66	2071718	WASHER NYLON	117	2071560	COLLAR TUBE
18	701-009	O-RING —THRU BOLT [2.EA]	67	2073412	SCREW 1/4 - 28"HHC	118	2223468	SCREW 8-32 [4 EA.]
19	830-027	SCREW -SELF THREAD 10-32X2 [2.EA]	68	2073418	SCREW 10-32 SS	119	2263201	CLAMP WIRE HARNESS
20	830-094	THRU BOLT 12-24X10.31 [2.EA]	■	2991772	BRACKET/BEARING ASSEMBLY	120	2264015	LIGHT INDICATOR
21	973-025	SPACER- BRUSH PLATE [2.EA]	*69	2261531	BEARING	121	2372100	SCREW 8-18 SS [2 EA.]
22	990-051	WASHER- STEEL	*70	2262051	BRACKET BASE BOTTOM	122	2073416	SCREW 8-32 SS SHCS [2 EA.]
23	990-052	WASHER- NYLATRON	71	2261535	SPRING SLEEVE	123	2303412	SCREW 6-20 [2 EA.]
24	2316246	MOTOR ASSEMBLY 24V 4" VARS 52"	72	2772318	BRACKET BASE TOP W/ EYELET	124	2303412	SCREW 6-20 X 5/8" [6 EA.]
25	2072011	TUBE- COMPOSITE 3:1 52"	73	2262315	EYELET ROPE	125	2071525	SPACER-INDICATOR LIGHT
■	1378132	PROPELLER KIT	74	2262705	SPRING BOWGUARD	126	2992205	PINION - MAIN
26	2331160	PROPELLER W/WEDGE 2	75	2263422	SCREW 5/16-18" X 1" SHCS SS	127	2998601	INDICATOR ASSEMBLY
27	2091701	WASHER-5/16 SS	76	2263424	SCREW 5/16-18" X 2-1/2" SHCS SS [2 EA.]	128	2075618	DECAL COVER RT 80 W/3X
28	2198401	ANODE	77	2333100	SPEED NUT	■	2994830	BAG ASSEMBLY - MAXXUM VECTOR
29	2262658	PIN-DRIVE	78	2070105	KNOB-TENSION SLEEVE	*129	2263431	1/4-20X3.5" PPH [6.EA]
30	2261722	WASHER 1/4 FLAT SS [2.EA]	79	2070118	COVER-PIVOT KNOB [2 EA.]	*130	2261713	WASHER 1/4 FLAT SS [6.EA]
31	2223100	NUT- TENSION 5/16-18 SS [2 EA.]	80	2070110	PIVOT KNOB [2 EA.]	*131	2263103	NUT 1/4-20 NYLOC-JAM SS [6.EA]
32	2262604	PIN- BWGRD UPPER THREADED	82	2070206	COVER 3:1	132	2072815	BRACKET-TILT STOP
33	2262606	CLEVIS PIN MAXXUM BWGRD-SS	83	2070800	COUPLER SOCKET	133	2261622	COLLAR HALF [2 EA.]
35	2260800	SPRING CLIP-SS	84	2070810	COUPLER DRIVE	134	2263453	SCREW 1/4-20 X 1" [2 EA.]
36	2150400	PULL-GRIP	85	2071500	COLLAR-LOWER	135	2052900	STRAIN RELIEF
37	2151700	WASHER-EYE SHAFT(.562 OD)	86	2071513	YOKE-PIVOT SUPPORT	136	2090650	LEADWIRE
■	2991857	MOUNT, BOW ASSEMBLY	87	2071710	WASHER NYLATRON [2 EA.]	■	2994832	BAG ASSEMBLY-MAXXUM VECTOR
38	2264244	ARM-UPPER SW,STD.	88	2071712	WASHER SS	*137	2261505	SPACER, MOTOR REST [6.EA]
39	2293501	BUSHING, STAINLESS STEEL [4.EA]	89	2071714	WASHER FLAT #6 [2 EA.]	*138	2263434	SCREW, 8-18 X 1" PPH SS [2.EA]
40	2263500	BOLT- SHOULDER (MAXXUM) [2.EA]	90	2071900	IDLER PLATE	139	2990404	PIVOT HANDLE ASSEMBLY
41	2994310	ARM-LOWER ASSEMBLY,STD.,SW,EXT	91	2071905	BRACKET- SENSOR SWITCH	140	2072102	SCREW #6 X 1/4" [2 EA.]
42	2263914	MOTOR REST STD. MAXXUM	92	2072091	OUTER TUBE 3:1 52"	141	2070425	HANDLE TUBE
43	2065676	DECAL-MAXXUM,MOTOR REST [2.EA]	93	2072210	GEAR CARRIER	142	2070411	LATCH-BUTTON
45	2993983	BOWPLATE,STD.,SW-MACH/INSERT	94	2072215	GEAR- IDLER	143	2070010	BEARING
46	2251601	ROPE (40"), MAXXUM MOUNT	95	2072502	CONTROL BOX	144	2990930A	HANDLE ASSEMBLY-EXT.
47	2261707	WASHER-3/8X1/2X.010" SS [2.EA]	96	2072705	SPRING DETENT	145	2263804	STRAP-HOLD DOWN
48	2236000	BEARING NYLINER-[2.EA]	97	2072710	SPRING TENSION SLEEVE	146	2332101	SCREW #8-32 X 1/2"SS [2 EA.]
50	2152612	SPRING-PIN LOCKBAR [2.EA]	98	2072810	DETENT BLOCK-TILT	147	2071720	#4 WASHER SS
51	2233621	LOCK BAR- BOW MOUNT	99	2072811	DETENT BLOCK-SWITCH	148	2373440	#4 SCREW SS
52	2233623	LOCK BAR, REAR - SS	100	2072900	RETAINER COUPLER	200	2075120	URETHANE PAD
53	2152701	SPRING-LOCKBAR-SS	101	2073000	RING PRELOAD			

