

RT 80/B
80 LBS THRUST
24 VOLT 56 AMPS
52" or 62" SHAFT

for use with "WWAF" serial numbers
3-year warranty from the date of purchase

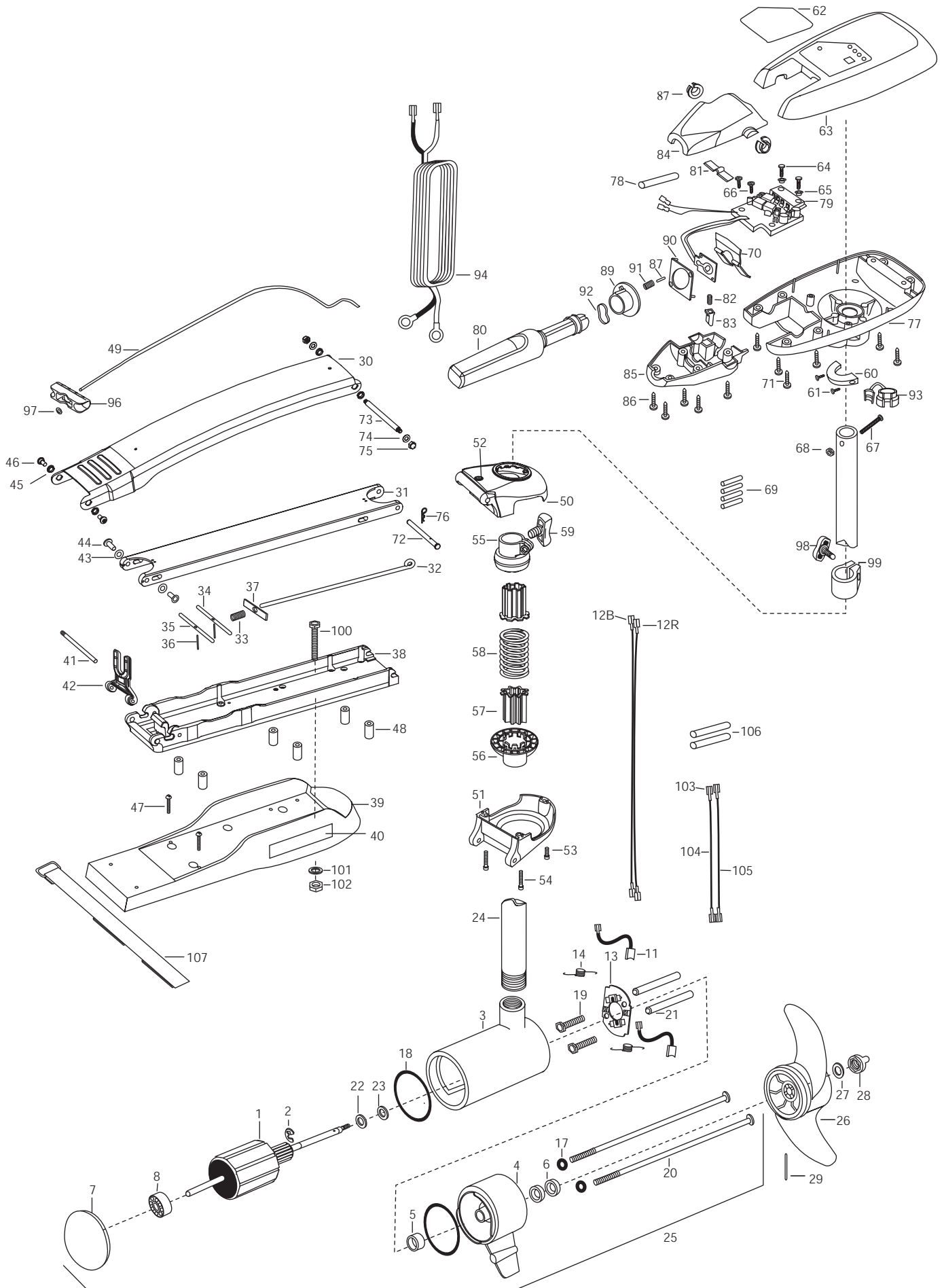

1	2-100-213	ARMATURE ASSEMBLY 24V 4.0 74#	38	2993982	BOWPLATE/INSERT LONG, SW- 62"	74	2261722	WASHER- FLAT 5.16-18 SS [2.EA]
2	788-040	RETAINING RING		2993983	BOWPLATE/INSERT STD, SW- 52"	75	2223100	NUT- TENSION 5/16 [2.EA]
3	2-200-397	CENTER HOUSING ASSEMBLY 4.0 MAGNE	39	2263915	MOTOR REST LONG-MAXXUM WHITE - 62"	76	2260806	CLIP- HAIR SPRING
4	2-300-340	BRUSH END HOUSING ASSEMBLY 4.0 SW		2263914	MOTOR REST STD- MAXXUM WHITE - 52"	77	2062596	CONTROL BOX- SW WHT
5	144-017	BEARING- FLANGE	40	2065676	DECAL- MOTOR REST RT W [2.EA]	78	2305410	SHRINK TUBING
6	880-025	SEAL [2.EA]	41	2260505	PIN- HINGE (HEADLESS) SS	79	2344006	CONTROL BOARD ASSEMBLY SW (HC)
7	421-360	PLAIN END HOUSING ASSEMBLY 4.0	42	2293811	YOKE- MAX MOUNT- POLYPROPYLENE	80	2990915	HANDLE ASSEMBLY W/O U- JOINT
8	140-010	BALL BEARING	43	2261708	WASHER- 3/8 X 1/2 X .010 SS [2.EA]	81	2302742	SPRING- DETENT (OFF) SS
11	186-094	BRUSH 4" W/TERMINAL [2.EA]	44	2236000	BEARING- NYLINER [2.EA]	82	2302745	SPRING- RELEASE BUTTON SS
12B	640-017	BRUSH WIRE 10 AWG- BLACK 61	45	2293501	BUSHING- STAINLESS STEEL [4.EA]	83	2303720	RELEASE BUTTON- HANDLE
12R	640-121	BRUSH WIRE 10 AWG- RED 62.5	46	2263500	BOLT- SHOULDER (MAXXUM) [2.EA]	84	2060411	HANDLE TOP HALF- MAXIMIZE
13	738-004	BRUSH PLATE- 4" TERMINAL	47	2263434	SCREW- #8-18X1 PPH SS [2.EA] --52"	85	2060415	HANDLE LOWER HALF
14	975-041	SPRING- TORSION [2.EA]	48	2261505	SPACER- MOTOR REST [6.EA] --52"	86	2303412	SCREW - 6-20 X 5/8 SELF TAP [5.EA]
17	701-009	O-RING- THRU BOLT [2.EA]	49	2251601	ROPE- 40", MAXXUM MOUNT	87	2060005	BEARING- HANDLE PIVOT [2.EA]
18	701-043	O-RING [2.EA]	■	2994833	BAG ASSEMBLY, MAX STABILIZER KIT - 62"	88	2302600	PIN- ACTUATOR
19	830-027	SCREW- SELF-THREAD 10-32 X 2 [2.EA]	■	2991846	BOWGUARD ASSEMBLY SW WHT HCT	89	2302850	ACTUATOR- CAM
20	830-094	THRU BOLT- 12-24 X 10.31 [2.EA]	50	2261968	BRACKET BASE TOP/EYELET ASSMBLY WHT	90	2302851	ACTUATOR- FWD/REV
21	973-025	SPACER- BRUSH PLATE [2.EA]	51	2991877	BRACKET BOTTOM/BEARING ASSMBLY WHT	91	2302740	SPRING- ACTUATOR
22	990-051	WASHER- STEEL THRUST	52	2772352	EYELET KIT -ROPE	92	2302741	SPRING- CAM (ZNC PLT STEEL)
23	990-052	WASHER- NYLATRON	53	9954533	SCREW- 1/4-20 X 3/4 SS SHC	93	2052900	STRAIN RELIEF- C.CORD/C
24	2032085	TUBE- COMPOSITE - WHT - 62"	54	2263404	SCREW- 1/4-20 X 2-1/4 SHCP, SS [2.EA]	94	2090650	LEADWIRE- 10 GA (RINGS)
	2032034	TUBE- COMPOSITE- WHT - 52"	■	2884701	SLEEVE/INSERT KIT	96	2150400	PULL- GRIP
25	2316244	MOTOR ASSEMBLY 24V 4 VARS SW 74W	55	2261525	SPRING- SLEEVE, UPPER	97	2151700	WASHER- EYE SHAFT (.562 OD)
■	1378132	PROPELLER KIT	56	2261535	SPRING- SLEEVE, LOWER	98	2011366	SCREW- COLLAR/NEW KNOB SS
26	2331160	PROPELLER- W/WEDGE 2	57	2264702	INSERT- TUBE (2 PER) B.MNT	99	2031520	COLLAR- DEPTH (W/O INSERT)
27	2091701	WASHER (LARGE)	58	2262705	SPRING- BOWGUARD, SS	■	2994832	BAG ASSEMBLY- MAX- 62"
28	2198401	ANODE-ZINC 4.0 LWR UNIT	59	2011366	SCREW- COLLAR/NEW KNOB SS	■	2994830	BAG ASSEMBLY- MAXXUM
29	2262658	PIN- DRIVE SS	60	2061517	COLLAR- CTRL BOX SW WHITE	*100	2263431	SCREW- 1/4-20 X 3.5 PPH [6.EA]
■	2771844	MOUNT, BOW ASMB, SW LONG - 62" W/BG	61	2263434	SCREW- #8X1" PPH TYPE 25 SS	*101	2261713	WASHER- 1/4 FLAT SS [6.EA]
	2771843	MOUNT, BOW ASMB, SW STD - 52" W/BG	62	2095684	DECAL- COVER RT80/B/HC	*102	2263103	NUT- 1/4-20 NYLOCK JAM SS [6.EA]
30	2264249	ARM UPPER- SW LNG WHT - 62"	63	2300219	COVER- CONTROL BOX RIPTIDE WHITE	103	2030710	CONNECTOR BUTT- 62" [2.EA]
	2264244	ARM UPPER- SW STD WHT- 52"	64	2301310	SCREW- #8-18 X1/2 SS [2.EA]	104	2030317	WIRE EXTENSION- 18" RED - 62"
31	2994320	ARM- LOWER ASSEMBLY LG WHT SW- 62"	65	2301710	WASHER- INSUL. (TRANSF.BAR) [2.EA]	105	2030316	WIRE EXTENSION- 18" BLACK - 62"
	2994310	ARM- LOWER ASSEMBLY STD WHT SW-52"	66	2372100	SCREW- #8-18X5/8 THD SS [2.EA]	106	2305401	SHRINK TUBE- .374 X 1 1/2"-62" [2.EA]
32	2153605	EYE SHAFT- 2LOCKBAR LONG SS- 62"	67	2263406	SCREW- #10-24 ZP 2 SS	107	2263802	STRAP- HOLD DOWN VELCRO 62"
	2153603	EYE SHAFT- 2LOCKBAR STD SS - 52"	68	2333101	NUT- HEX #10-24 UNC NYLOCK SS			
33	2152701	SPRING- LOCKBAR SS	69	2305401	SHRINK TUBE- .374 X 1.50 [4 EA.]			
34	2233601	LOCKBAR SS	70	2302743	SPRING- DETENT (HANDLE-TILT)			
35	2233603	LOCKBAR- REAR- SS	71	2303412	SCREW- #6-20 X 5/8 SELF TAP [6.EA]			
36	2152610	SPRING- PIN LOCKBAR [2.EA]	72	2262606	PIN- CLEVIS SS MAXXUM BWGRD			
37	2262703	SPRING STOP MAXXUM	73	2262604	PIN - BWGRD UPPER THREADED SS			

BLACK LEADS B-

CONTROL BOARD

POT BOARD

RED M+

RED M+

BLACK M-

BLACK M-

RED LEADS B+

CONNECTING WIRE

