

VECTOR 70

for use with "WWAF" serial numbers
2-year warranty from the date of purchase

70LBS. THRUST
24 VOLT 42 AMPS
42" SHAFT

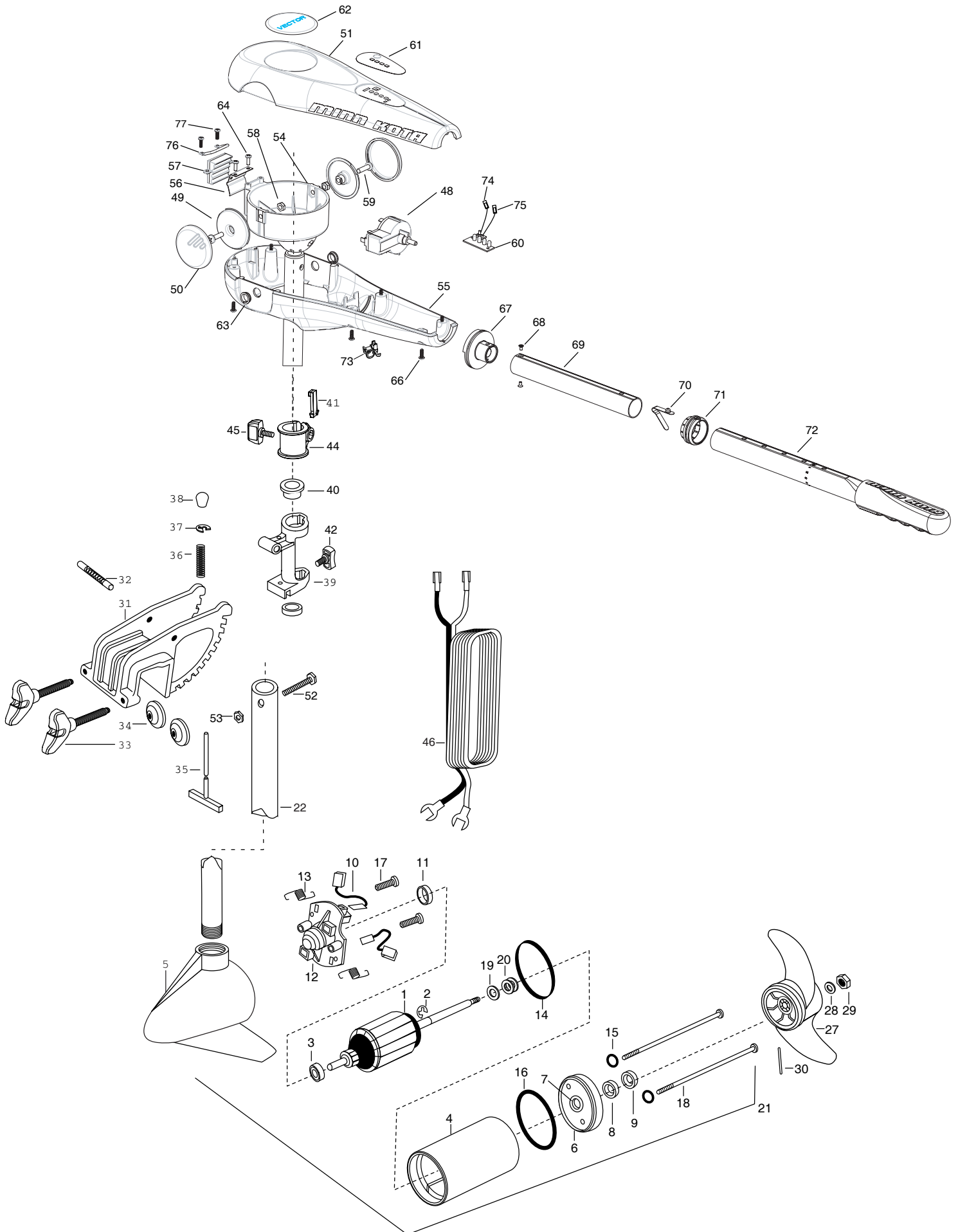

1	2-100-119	ARMATURE ASSEMBLY 24V 3.625 5SPC 65#	41	2062800	TENSION BLOCK- SNAP IN
2	788-015	RETAINING RING	42	2011385	SCREW-TENSION/NEW KNOB
3	140-010	BALL BEARING	44	2061520	COLLAR-DEPTH ((ENDURA)
4	2-200-005	CENTER HOUSING ASSEMBLY 3.625 FW TXT	45	2011365	SCREW-COLLAR W/NEW KNOB
5	2-300-039	BRUSH END HOUSING ASSEMBLY 3.62 SPCO	46	2050609	LEADWIRE 10 GA SPADE TERM
6	2-400-101	PLAIN END HOUSING ASSEMBLY	48	2064023	SWITCH - 5 SPD.
7	144-049	BEARING - FLANGE (SERVICE ONLY)	49	2070110	PIVOT KNOB [2 EA.]
8	880-003	SEAL	50	2070115	COVER PIVOT KNOB [2 EA.]
9	880-006	SEAL WITH SHIELD	51	2070211	CONTROL BOX COVER
10	188-036	BRUSH ASSEMBLY [2.EA]	52	2033401	SCREW 10-24 X 1-3/4"
11	725-050	BRUSH RETENTION- PAPER TUBE	53	2013110	NUT-HEX ZINC/CAD PLATE
12	738-036	BRUSH PLATE W/HOLDER	54	2071520	YOKE PIVOT
13	975-040	SPRING - TORSION [2.EA]	55	2072501	CONTROL BOX
14	337-036	GASKET	56	2072705	SPRING DETENT
15	701-008	O-RING, THRU-BOLT [2.EA]	57	2072810	DETENT BLOCK, TILT
16	701-081	O-RING	58	2073100	NUT, 1/4-20" NYLOK [2 EA.]
17	830-007	SCREW-8-32 [2.EA]	59	2073408	SCREW 1/4-20" [2 EA.]
18	830-042	THRU-BOLT 10-32X8.83" [2.EA]	60	2074071	BATTERY METER
19	990-067	WASHER- STEEL THRUST	61	2075604	DECAL-COVER 70T VECTOR
20	990-070	WASHER - NYLATRON [2.EA]	62	2075605	DECAL-COVER PLUG
21	2096034	MOTOR ASSEMBLY 24V 3.62 5 SPD F/W 42"	63	2077316	BUSHING
22	2032053	TUBE- COMPOSITE 42"	64	2372100	SCREW 8-18 X 1/2" [2 EA.]
■	1378131	PROP KIT	66	2012100	SCREW 8-18 X 5/8" [6 EA.]
27	2091160	PROP- WEEDLESS WEDGE 2	67	2070407	PIVOT HANDLE
28	2151726	WASHER- 5/15 STD SS	68	2072102	SCREW #6 X 1/4"
29	2053101	NUT-PROP NYLOC 5/16 SS	69	2070425	HANDLE TUBE
30	2092600	PIN-DRIVE SS	70	2070411	LATCH, BUTTON
■	2991908	BRACKET & HINGE ASSEMBLY	71	2070010	BEARING-FRONT
■	2771901	BRACKET W/CLAMP SCREW ASSEMBLY (INCL.31,33,34)	72	2990941A	HANDLE ASSEMBLY-EXT.
*31	2031931	BRACKET DIE CAST	73	2052900	STRAIN RELIEF
32	2010511	PIN-HINGE- ENDURA	74	2070304	WIRE BATTERY METER BLACK
*33	2061300	SCREW- CLAMP [2 EA.]	75	2070305	WIRE BATTERY METER RED
*34	2011710	WASHER- CLAMP SCREW 1.5OD [2 EA.]	76	2072815	BRACKET - TILT STOP
35	2033601	T-BAR METAL	77	2332101	SCREW #8-32 X 1/2" SS [2 EA.]
36	2012700	SPRING- T-BAR ENDURA			
37	2013000	E-RING			
38	2010100	TILT KNOB			
39	2031852	HINGE-MACHINED			
40	2037301	BUSHING-HINGE [2.EA]			

