

55 AT / H
55 lbs Thrust
12 Volt 50 Amps
52" Shaft

for use with "WWAG" serial numbers
2-year warranty from the date of purchase

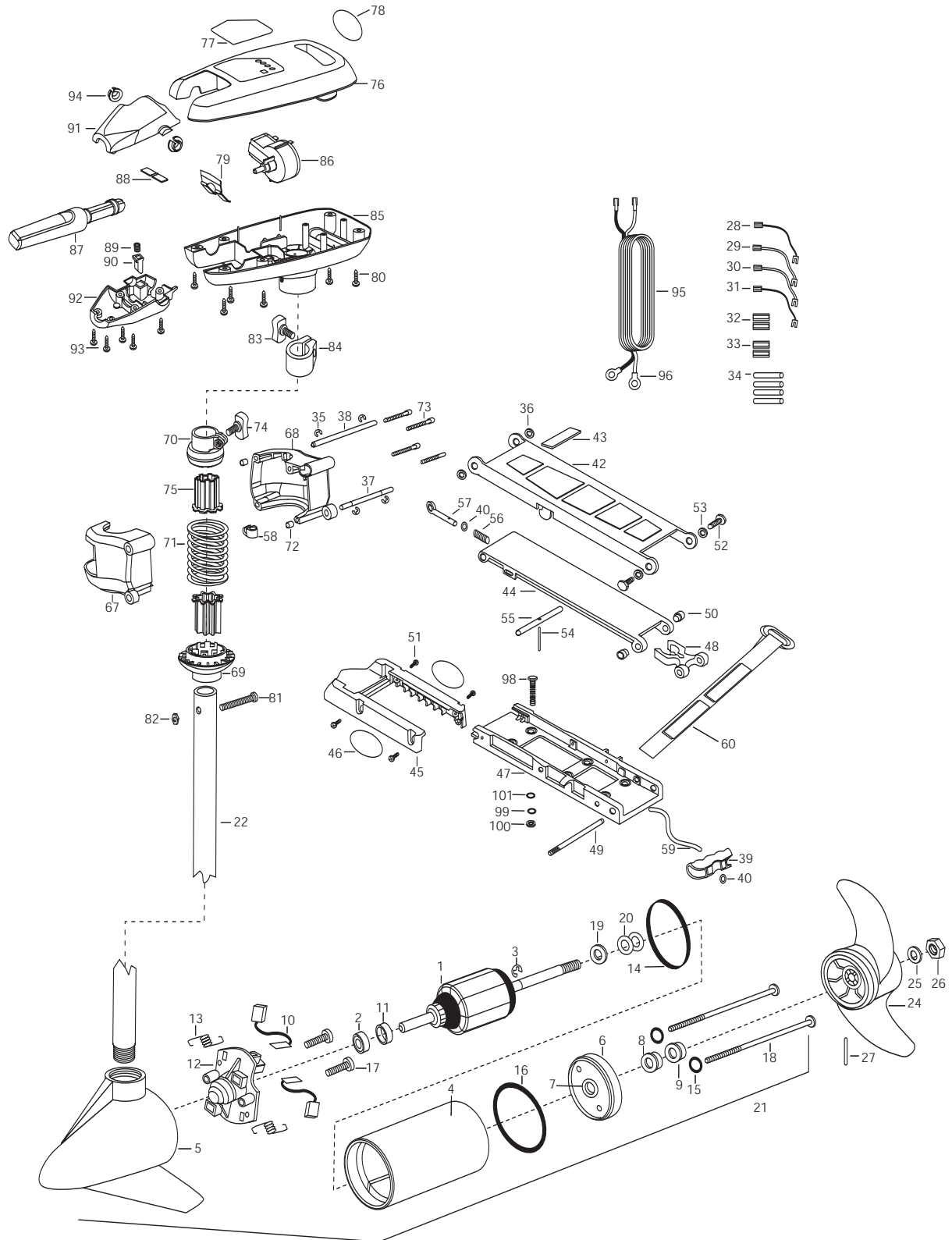

1	2-100-115	ARMATURE ASSEMBLY 24V 3.625 65#	35	2263010	E-RING 3/8 DIA SHAFT [4,EA]	69	2261535	SPRING SLEEVE LWR
2	140-010	BEARING-BALL	36	2293500	BUSHING-SHOULDER UPR ARM [2.EA]	70	2261525	SPRING-SLEEVE UPPER
3	788-015	RETAINING RING	37	2260530	HINGE-PIN LOWER SS	71	2262704	SPRING-BOWGUARD HAND CT
4	431-101	CENTER HOUSING ASSEMBLY	38	2260520	HINGE-PIN UPPER SS	72	2267300	BUSHING-DOWEL [2.EA]
5	2-300-196	BRUSH END HOUSING ASSEMBLY SPDCO	39	2150400	PULL-GRIP	73	2263470	SCREW-1/4-20 X 1-3/4 [4.EA]
6	2-400-101	PLAIN END HOUSING ASSEMBLY	40	2151700	WASHER-EYE SHAFT .562 OD [2.EA]	74	2011365	SCREW-COLLAR/NEW KNOB
7	144-049	BEARING- FLANGE SERVICE ONLY	■	2771873	BOW MOUNT ASSEMBLY	75	2264702	INSERT- TUBE 2PER
8	**880-003	SEAL	42	2264221	ARM-UPPER, STD, FW	76	2060283	COVER-CONTROL BOX
9	**880-006	SEAL-W/SHIELD	43	2265120	BUMPER UPPER ARM	77	2185609	DECAL-COVER 55AT/H
10	188-036	BRUSH ASSEMBLY [2.EA]	44	2254353	ARM-LWR AT FW MACH'D BG360	79	2302743	SPRING-DETENT HANDLE-TILT
11	725-050	TUBE- BRUSH RETENTION	45	2263900	MOTOR REST A/T	80	2303412	SCREW-6-20 X 5/8 SELF TAP [6.EA]
12	738-036	BRUSH PLATE WITH HOLDER	46	2265631	DECAL- MOTOR REST [2 EA.]	81	2033400	SCREW-10-24 X 1-3/4]
13	975-040	SPRING- TORSION [2.EA]	47	2251937	BOW PLATE-MACHINED	82	2013110	NUT-10-24 HEX (ZCP)
14	**337-036	GASKET	48	2293801	TUBE LOCK-'D'	83	2011365	SCREW-COLLAR/NEW KNOB
15	**701-008	O-RING THRU BOLT [2.EA]	49	2260506	HINGE-PIN (HEADLESS) ZINC [2.EA]	84	2031520	COLLAR-DEPTH W/O INSERT
16	**701-081	O-RING	50	2236000	BEARING NYLINER- [2.EA]	85	2062551	CONTROL BOX PLAS W/HAND
17	830-007	#8-32 SCREW [2.EA]	51	2303431	SCREW 1/4-20X5/8'PPH [4.EA]	86	2064023	SWITCH-FWD/REV 5SP
18	830-042	THRU BOLT 10-32X9.205 [2.EA]	52	2293511	BOLT-UPPER ARM W/LOCTITE [2.EA]	87	2990912	HANDLE ASSEMBLY-W/U-JOINT 5SP
19	990-067	WASHER- STEEL THRUST	53	2293500	BUSHING-SHOULDER UPR ARM [2.EA]	88	2302742	SPRING-DETENT OFF
20	990-070	WASHER-NYLATRON [2.EA]	54	2152610	SPRING-PIN LOCKBAR	89	2302745	SPRING-RELEASE BUTTON
21	2097099	MOTOR ASSEMBLY 12V F/W 3.625 5SPCO	55	2233600	LOCK BAR- BOW MOUNT	90	2303720	RELEASE BUTTON-HANDLE
22	2032068	TUBE- COMPOSITE-52"	56	2152700	SPRING- LOCKBAR CAD.PLTH	91	2060408	HANDLE- TOP HALF
■	1378131	PROPELLER KIT	57	2153600	EYE SHAFT-CAD.PLATE	92	2060415	HANDLE- LOWER HALF
*24	2091160	PROPELLER- W/WEDGE 2	58	2262310	GUIDE-ROPE	93	2303412	SCREW-6-20 X 5/8 SELF TAP [5.EA]
*25	2151726	WASHER- 5/16 SS	59	2251600	ROPE- 31'	94	2060005	BEARING-HANDLE PIVOT [2.EA]
*26	2053101	NUT-PROP NYLOC MEDIUM	60	2267200	LATCH LEVER	95	2090600	LEADWIRE -10 GA RINGS
*27	2092600	PIN-DRIVE 95-4HP'S	61	2263800	STRAP-HOLD DOWN	96	2020700	TERMINAL RING, 3/8' [2.EA]
28	2030312	WIRE EXTENSION 18"-16GA N	62	2261910	BRACKET HOLD DOWN STRAP	■	2994838	BAG ASSEMBLY-BOLTS NUTS WASHERS
29	2030313	WIRE EXTENSION 18"-18GA YEL	63	2260500	PIN-ROLL LATCH LEVER [2.EA]	*98	2263462	SCREW 1/4-20X2 SS [6.EA]
30	2030316	WIRE EXTENSION 18"- BLK	64	2263440	SCREW-10-24 X 3/4	*99	2261713	WASHER-1/4 FLAT 18-18 [6.EA]
31	2030317	WIRE EXTENSION 18" - RED	65	2333101	NUT-HEX 3HP-SS NYLOC	*100	2263103	NUT- 1/4-20 NYLOC-JAM [6.EA]
32	2030710	CONNECTOR BUTT [2.EA]	■	2991873	BOWGUARD ASSEMBLY 65AT/H			
33	2030711	CONNECTOR BUTT [2.EA]	67	2261921	BRACKET BASE-LEFT			
34	2375400	SHRINK TUBE 1/4ODX1-3/4 [4.EA]	68	2261931	BRACKET BASE-RGHT			

**Seal & Oring Kit P/N 2888460 * This item is part of an assembly. This item cannot be sold separately due to machining and /or assembly that is required.

