

65AT
65 lbs Thrust, 24 volt, 40 amps
42", 45", 48", 52" Shaft

for use with "AG" serial numbers
2-year warranty from the date of purchase

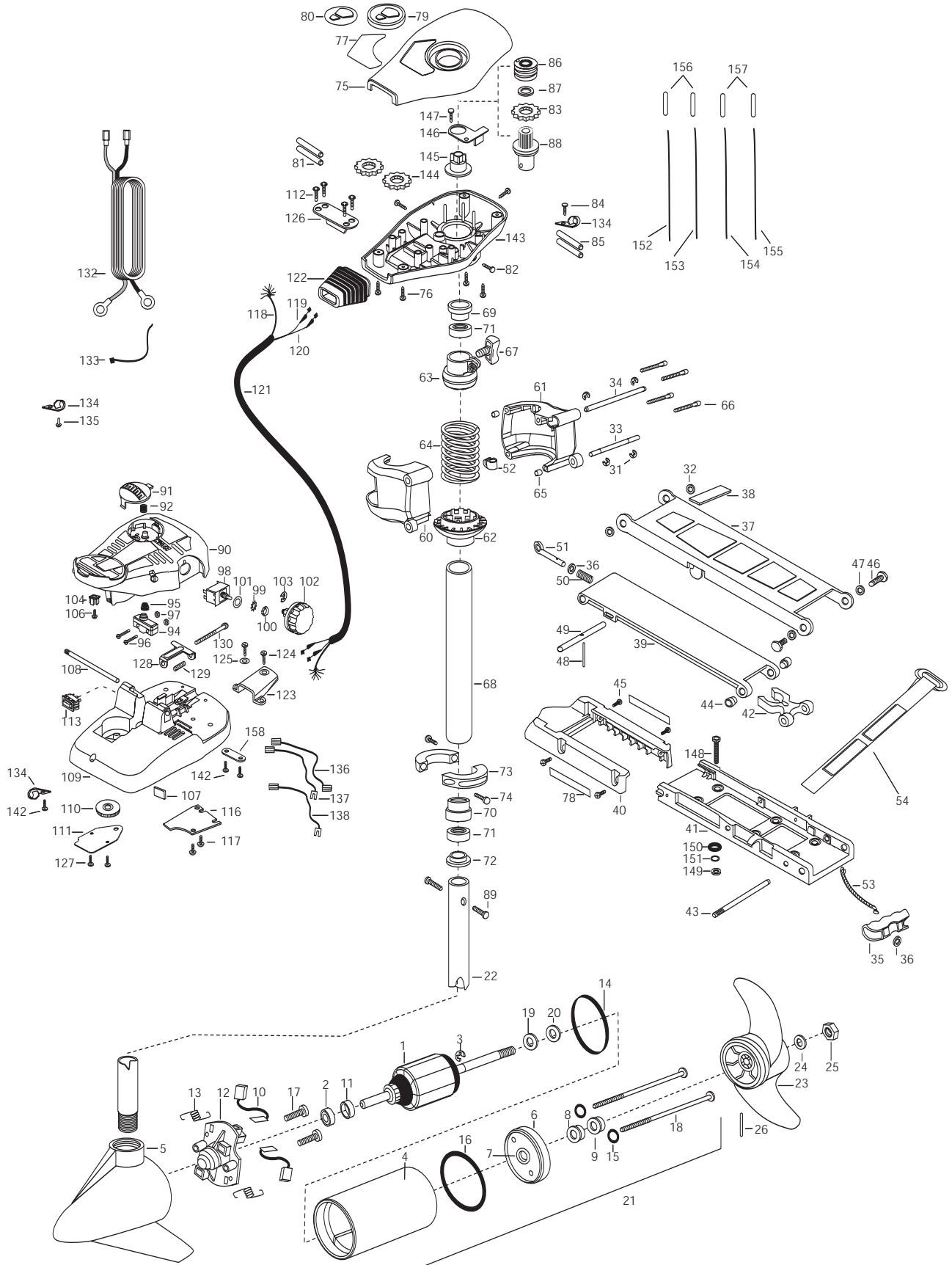

1	2-100-119	ARMATURE ASSEMBLY 24V 3.625 65#	51	2153600	EYE SHAFT-CAD.PLATE	103	2263000	E-RING TRU-ARC
2	140-010	BEARING-BALL	52	2262310	GUIDE-ROPE	104	2260730	CONNECTOR 1/4 MALE TAB
3	788-015	RETAINING RING	53	2251601	ROPE- 39"	106	2332103	SCREW-6-20 X 3/8 THD SS
4	431-005	CENTER HOUSING ASSEMBLY	54	2263805	VELCRO STRAP	107	2266413	TENSION SCREW PLATE- FTPEL
5	2-300-039	BRUSH END HOUSING 3.625 SPD CO	■	2991944	BOWGUARD ASSEMBLY FW 360	108	2060511	PIN- PIVOT A/T FT PDL
6	2-400-101	PLAIN END HOUSINGASSEMBLY 3.625	60	2261981	BRACKET BASE-LEFT	109	2992104	FT PED BASE/PIN ASSEMBLY
7	144-049	BEARING- FLANGE SERVICE ONLY	61	2261986	BRACKET BASE-RGHT	110	2262301	PULLEY FOOT PEDAL
8	880-003	**SEAL	62	2261535	SPRING SLEEVE, LOWER	111	2266401	COVER-PULLEY STAMPING
9	880-006	**SEAL-W/SHIELD	63	2261525	SPRING-SLEEVE UPPER	112	2223430	SCREW #8X3/4 PPH TYPE 25 [4.EA]
10	188-036	BRUSH ASSEMBLY [2.EA]	64	2262712	SPRING, BOWGUARD, NIK PL	113	2254031	SWITCH-MOM/OFF/COM
11	725-050	TUBE- BRUSH RETENTION	65	2267300	BUSHING-DOWEL [2.EA]	116	2266412	SWITCH PLATE, FT PEDAL
12	738-036	BRUSH PLATE WITH HOLDER	66	2263470	SCREW-1/4-20 X 1-3/4 SS [4.EA]	117	2332103	SCREW-6-20 X 3/8 THD SS [2.EA]
13	975-040	SPRING- TORSION [2.EA]	67	2011365	SCREW-COLLAR/NEW KNOB	118	2261208	WIRE HARNESS, A/T FT. PED
14	337-036	**GASKET	■	2992015	TUBE W/BEARING RACE ASSEMBLY 18"	119	2267505	CABLE ASSEMBLY-RIGHT 5'
15	701-008	**O-RING THRU BOLT [2.EA]		2992012	TUBE W/BEARING RACE ASSEMBLY 21"	120	2267515	CABLE ASSEMBLY-LEFT 5'
16	701-081	**O-RING		2992016	TUBE W/BEARING RACE ASSEMBLY 24"	121	2265430	CABLE JACKET 5"
17	830-007	#8-32 SCREW [2.EA]	68	2272066	TUBE OUTER-18" 4 HOLES	122	2265110	BOOT-CONTROL BOX
18	830-008	THRU BOLT 10-32X9.205 [2.EA]		2272069	TUBE OUTER-21" 4 HOLES	123	2265115	BOOT-FOOT PEDAL BASE
19	990-067	WASHER- STEEL THRUST		2272067	TUBE OUTER-24" 4 HOLES	124	2372100	SCREW-8-18 X 5/8 THD [2.EA]
20	990-070	WASHER-NYLATRON [2.EA]	69	2266260	BEARING RACE	125	2261714	WASHER-MAXXUM FT PDL [2.EA]
21	2096034	MOTOR ASSEMBLY 24V 3.625 5SPC FW 42"	70	2266220	BEARING RACE-STEEL	126	2261901	BRACKET-CONDUIT AT/MAX
	2096039	MOTOR ASSEMBLY 24V 3.625 5SPD FW 52"	71	2266000	BEARING BALL-STEEL [2.EA]	127	2301310	SCREW-8-18 X 1/2 [2.EA]
22	2032063	TUBE- COMPW/CSK HOLE-42"	72	2266115	BEARING CONE	128	2263210	BRACKET-CONDUIT ADJUSTMENT
	2032061	TUBE-COMP W/CSK HOLE- 45"	73	2261622	COLLAR HALF-ZINC-2 PER	129	2262720	SPRING-CONDUIT ADJUSTMENT
	2032064	TUBE- COMP W/CSK HOLE-48"	74	2263453	SCREW-1/4-20 X 3/4 [2.EA]	130	2263466	SCREW-1/4-20 X 2 STL PPH
	2032067	TUBE- COMPW/CSK HOLE-52"	75	2260284	COVER- CONTROL BOX AT/FC BLK	131	2335400	SHRINK TUBE-1/2 OD X 2
■	1378131	PROPELLER KIT	76	2372100	SCREW-8-18 X 5/8 THD SS [4.EA]	132	2261235	LEADWIRE
23	2091160	PROPELLER- W/WEDGE 2	77	2265659	DECAL-COVER 65AT	133	2256300	TIE WRAP-5.5' BLACK
24	2151726	WASHER- 5/16 SS	78	2265631	DECAL- MOTOR REST [2.EA]	134	2263201	CLAMP WIRE HARNESS MICRO [3.EA]
25	2053101	NUT-PROP NYLOC MEDIUM	79	2260150	POINTER DISC TRNSLCNT RED	135	2332103	SCREW-6-20 X 3/8 THD SS
26	2092600	PIN-DRIVE 95-4HP'S	80	2265800	DECAL-INDICATOR	136	2260301	CONNECTING WIRE SWITCH
31	2263010	E-RING 3/8 DIA. SHAFT [4.EA]	81	2375400	SHRINK TUBE-1/4OD X 1-3/4 [2.EA]	137	2260312	WIRE,BLK W/WHT STRP 19 1/2"
32	2293500	BUSHING-SHOULDER UPPER ARM [2.EA]	82	2053414	SCREW-#8-32 X 1/2 TRI-LOBE [3.EA]	138	2260322	WIRE,BLK W/BLUE STRP-12"
33	2260530	HINGE PIN-LOWER SS	83	2267800	GEAR-INDICATOR	142	9953104	SCREW-8 X 1/2 S/S [3.EA]
34	2260520	HINGE PIN-UPPER	84	2301310	SCREW-8-18 X 1/2	143	2262535	CONTROL BOX-PLASTIC A/Ts
35	2150400	PULL-GRIP	85	2355410	SHRINK TUBE-3/8 OD X 2 [2.EA]	144	2267800	GEAR-INDICATOR [2.EA]
36	2151700	WASHER-EYE SHAFT.562 OD	86	2232360	PULLEY-CABLE DRUM	145	2262220	INDICATOR-DRIVE
■	2771987	BOW MOUNT ASSEMBLY w/BOWGUARD 360	87	2261730	WASHER-NYLON A/T CON B	146	2261905	BRACKET/INDICATOR
37	2264221	ARM-UPPER STD FW	88	2776246	TOP BEARING RACE /PINION DRIVE	147	2301310	SCREW-8-18 X 1/2 SS
38	2265120	BUMPER- UPPER ARM	89	2263410	SCREW-8-32 X 5/16 ZN PL [2.EA]	■	2994838	BAG ASSEMBLY-BOLTS,NUTS,WASHER
39	2254353	ARM- LWR FW MCHD	90	2790002	FOOT PEDAL/PLUG ASSEMBLY AT	*148	2263462	SCREW- 14-20X2 SS [6.EA]
40	2263900	MOTOR REST	91	2263700	PUSH-BUTTON FOOT PEDAL	*149	2153103	NUT- 1/4-20 NYLOC JAM [6.EA]
41	2251937	BOW PLATE-D/C MCHD	92	2302732	SPRING-LOWER PEDAL SS	*150	2301720	WASHER- MOUNTING RUBBER [6.EA]
42	2293801	TUBE LOCK-D	94	2264020	SWITCH MOMENTARY	*151	2261713	WASHER- 1/4 FLAT 18-18 [6.EA]
43	2260506	HINGE-PIN HEADLESS ZINC	95	2265140	BOOT-MICROSWITCH	152	2260330	WIRE EXTENSION 10GA BLK. 9"
44	2236000	BEARING NYLINER- [2.EA]	96	2262114	SCREW-MOUNTING/SWITCH [2.EA]	153	2260331	WIRE EXTENSION 10GA RED 9"
45	2303431	SCREW 1/4-20X5/8 PPH [4.EA]	97	2233100	NUT-SWITCH MOUNT [2.EA]	154	2260332	WIRE EXTENSION 10GA WHITE
46	2293511	BOLT-UPPER ARM W/LOCTITE [2.EA]	98	2264026	SWITCH-5 SPEED AT	155	2260333	WIRE EXTENSION 10GA YELLOW
47	2293500	BUSHING-SHOULDER UPPER ARM [2.EA]	99	2261701	LOCKWASHER -STAR	156	2355410	SHRINK TUBE 3/8"OD X 2"
48	2152610	SPRING-PIN LOCKBAR	100	2263105	NUT-HEX	157	2375400	SHRINK TUBE 1/4"OD X 1 3/4"
49	2233600	LOCK BAR- BOW MOUNT	101	2261715	SPACER-SWITCH 5 SP MODELS	158	2263205	LEADWIRE CLAMP
50	2152700	SPRING-LOCKBAR CAD.PLTD	102	2260170	KNOB-SPEED CONTROL 5 SPD			

45"/48"/52"
MODELS

** Seal & Oring Kit P/N 2888460 * This item is part of an assembly. This item cannot be sold separately due to machining and /or assembly that is required.

P/N 2274973 REV. C 5-05

65AT is 24-volts!

