

MAXXUM 70 HC / SC
70 LBS THRUST
24 VOLT 42 AMPS
52" SHAFT

for use with "AG" serial numbers
3-year warranty from the date of purchase

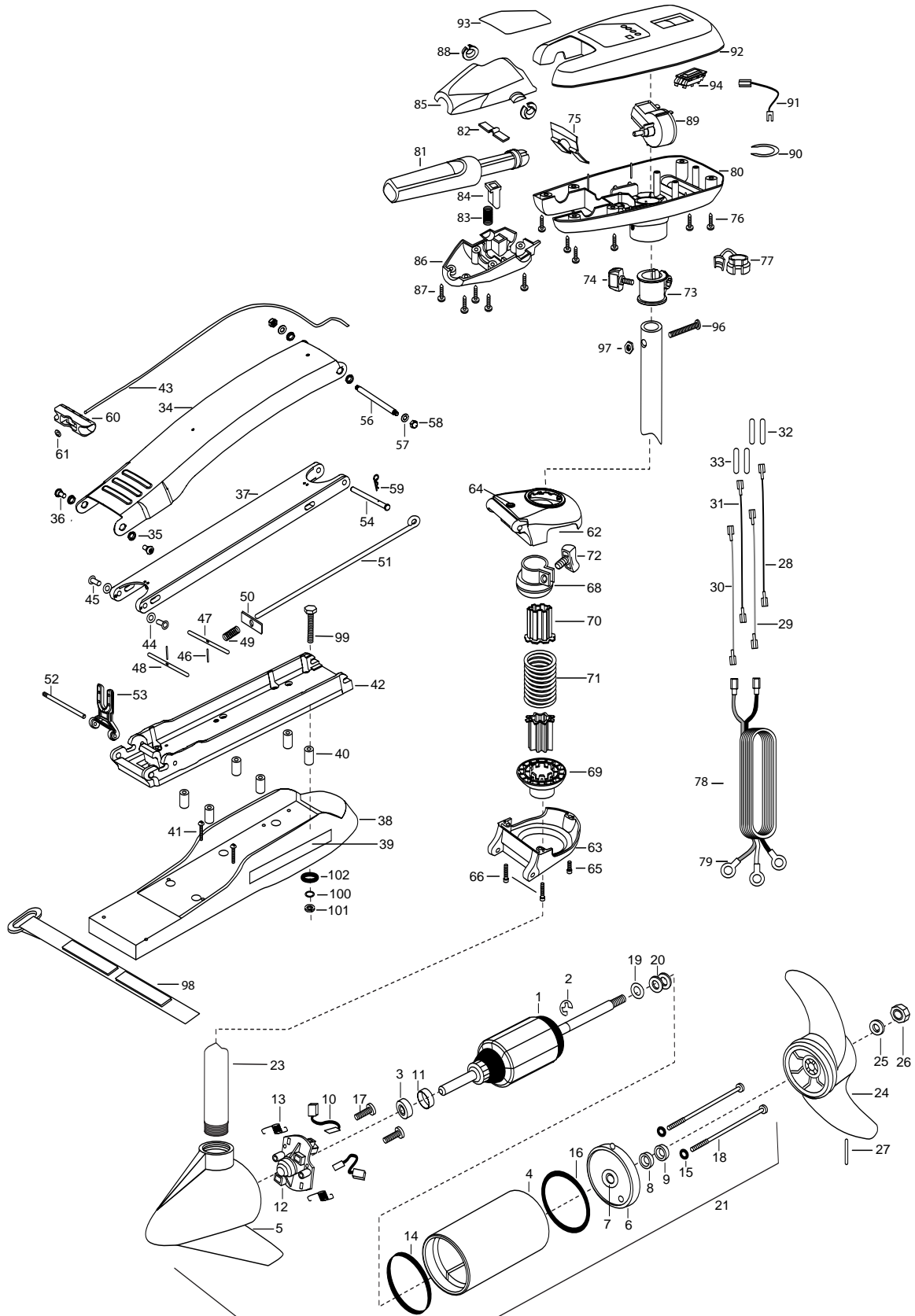

1	2-100-119	ARMATURE ASSEMBLY 12V 3.625 5SPC 55#	34	2264241	ARM-UPPER FW,STD	69	2261535	SPRING SLEEVE, LOWER
2	788-015	RETAINING RING	35	2293501	BUSHING, STAINLESS STEEL [4.EA]	70	2264702	INSERT-TUBE 2 PER B.MNT
3	140-010	BALL BEARING	36	2263500	BOLT, SHOULDER MAXXUM [2.EA]	71	2262704	SPRING, BOWGUARD, HAND CT
4	2-200-005	CENTER HOUSING ASSEMBLY 3.625 FW TXT	37	2774307	ARM-LOWER ASSEMBLY, STD, FW,	72	2011365	SCREW-COLLAR/NEW KNOB
5	2-300-139	BRUSH END HOUSING ASSEMBLY 3.62 SPCO	38	2263912	MOTOR REST MAXXUM	73	2031520	COLLAR-DEPTH W/O INSERT
6	2-400-101	PLAIN END HOUSING ASSEMBLY	39	2265514	DECAL- MAXXUM MOTOR REST [2.EA]	74	2011365	SCREW-COLLAR/NEW KNOB
7	144-049	BEARING - FLANGE (SERVICE ONLY)	40	2261505	SPACER, MOTOR REST [6.EA]	75	2302743	SPRING-DETENT HANDLE-TILT
8	880-003	**SEAL	41	2263434	SCREW- #8-18 X 1 PPH SS [2.EA]	76	2303412	SCREW-#6-20 X 5/8 SELF TAP [6.EA]
9	880-006	SEAL WITH SHIELD	42	2773987	BOWPLATE W/INSERT	77	2052900	STRAIN RELIEF-C.CORD/SP.C
10	188-036	BRUSH ASSEMBLY [2.EA]	43	2251601	ROPE (40'), MAXXUM MOUNT	78	2090612	LEADWIRE 12/24V (10 GA) RINGS
11	725-050	BRUSH RETENTION- PAPER TUBE	44	2261708	WASHER-3/8X1/2X.010 [2.EA]	79	2020700	TERMINAL RING, 3/8 [3.EA]
12	738-036	BRUSH PLATE W/HOLDER	45	2236000	BEARING NYLINER- [2.EA]	80	2062565	CONTROL BOX
13	975-040	SPRING - TORSION [2.EA]	46	2152610	SPRING-PIN LOCKEAR [2.EA]	81	2990912	HANDLE ASSEMBLY W/O U-JOINT 5SP
14	337-036	**GASKET	47	2233600	LOCK BAR- BOW MOUNT	82	2302742	SPRING-DETENT (OFF)
15	701-008	**O-RING, THRU-BOLT [2.EA]	48	2233602	LOCK BAR, REAR - ZINC	83	2302745	SPRING-RELEASE BUTTON
16	701-081	**O-RING	49	2152700	SPRING-(LOCKBAR) CAD.PLTD	84	2303720	RELEASE BUTTON-HANDLE
17	830-007	SCREW-8-32 [2.EA]	50	2262703	SPRING STOP MAXXUM	85	2060408	HANDLE -TOP HALF
18	830-008	THRU-BOLT 10-32X9.21" [2.EA]	51	2153602	EYE SHAFT-2LOCKBAR STD PLTD	86	2060415	HANDLE -LOWER HALF
19	990-067	WASHER- STEEL THRUST	52	2260506	HINGE-PIN (HEADLESS) ZINC	87	2303412	SCREW- #6-20 X 5/8 SELF TAP [5.EA]
20	990-070	WASHER - NYLATRON [2.EA]	53	2293811	YOKE,MAX MNT-POLYPROPYLENE	88	2060005	BEARING-HANDLE PIVOT [2.EA]
21	2096039	MOTOR ASSEMBLY 12V 3.625 5SPC FW 70#	54	2262607	PIN-CLEVIS ZP MAXXUM BG	89	2064023	SWITCH- FWD REV 5 SP
23	2032068	TUBE COMPOSITE 52"	56	2262605	PIN-BWGRD UPPER THREADED ZP	90	2303001	RING- PIG #2
■	1378131	PROPELLER KIT WW2	57	2261722	WASHER- FLAT [2.EA]	91	2250322	CONNECTING WIRE 7"
*24	2091160	PROPELLER (W.WEDGE 2)	58	2223100	NUT- TENSION 5/16-18 SS [2.EA]	92	2060286	CTRL BOX CVR- BLACK
*25	2151726	WASHER-5/16 STD SS	59	2260805	CLIP- SPRING ZP MAX BG	93	2185612	DECAL-COVER MAX70SC/HC
*26	2053101	NUT-PROP,NYLOC (MED) 5/16 SS	60	2150400	PULL-GRIP	94	2254032	SWITCH- 12V/OFF/24V 65AT
*27	2092600	PIN-DRIVE (95-4HP'S) SS	61	2151700	WASHER-EYE SHAFT .562 OD	96	2033400	SCREW-#10-24 X1-3/4 PPH ZINC
28	2030330	WIRE EXTENSION-9" -BLACK	■	2991760	BOWGUARD ASSEMBLY-HAND CTRL	97	2013110	NUT-10-24 HEX
29	2030331	WIRE EXTENSION-9" -RED	62	2261976	BRKT BASE TOP	98	2263804	STRAP- HOLD DWN 30.5 VELC
30	2030332	WIRE EXTENSION-9" -WHITE	63	2991770	BRKT BTM/BEARING FW ASEMBLY	■	2994830	BAG ASSEMBLY-MAXXUM
31	2030333	WIRE EXTENSION-9" -YELLOW	64	2772352	EYELET- KIT	*99	2263431	SCREW 1/4-20 X 3.5 PPH [6.EA]
32	2355410	SHRINK TUBE-3/8 OD X 2 [2.EA]	65	2263423	SCREW 5/16-18 X 1 SHCS ZINC	*100	2261713	WASHER-1/4 FLAT S/S [6.EA]
33	2375400	SHRINK TUBE-1/4 OD X 1-3/4 [2.EA]	66	2263425	SCREW-5/16-18 X 2 1/2 SHCS [2.EA]	*101	2263103	NUT-1/4-20 NYLOCK-JAM S/S [6.EA]
■	2991840	MOUNT, BOW ASSEMBLY W/BOWGRD	68	2261525	SPRING-SLEEVE UPPER	*102	2301720	WASHER-MOUNTING*RUBBER [6.EA]

** Seal & Oring Kit P/N 2888460

* This item is part of an assembly. This item cannot be sold separately due to machining and /or assembly that is required.

P/N 2184908 REV. B 8-05

