

**MAXXUM 80 FC**  
80 lbs Thrust  
24 volt 56 amps  
72" SHAFT

for use with "AG" serial numbers  
3-year warranty from the date of purchase

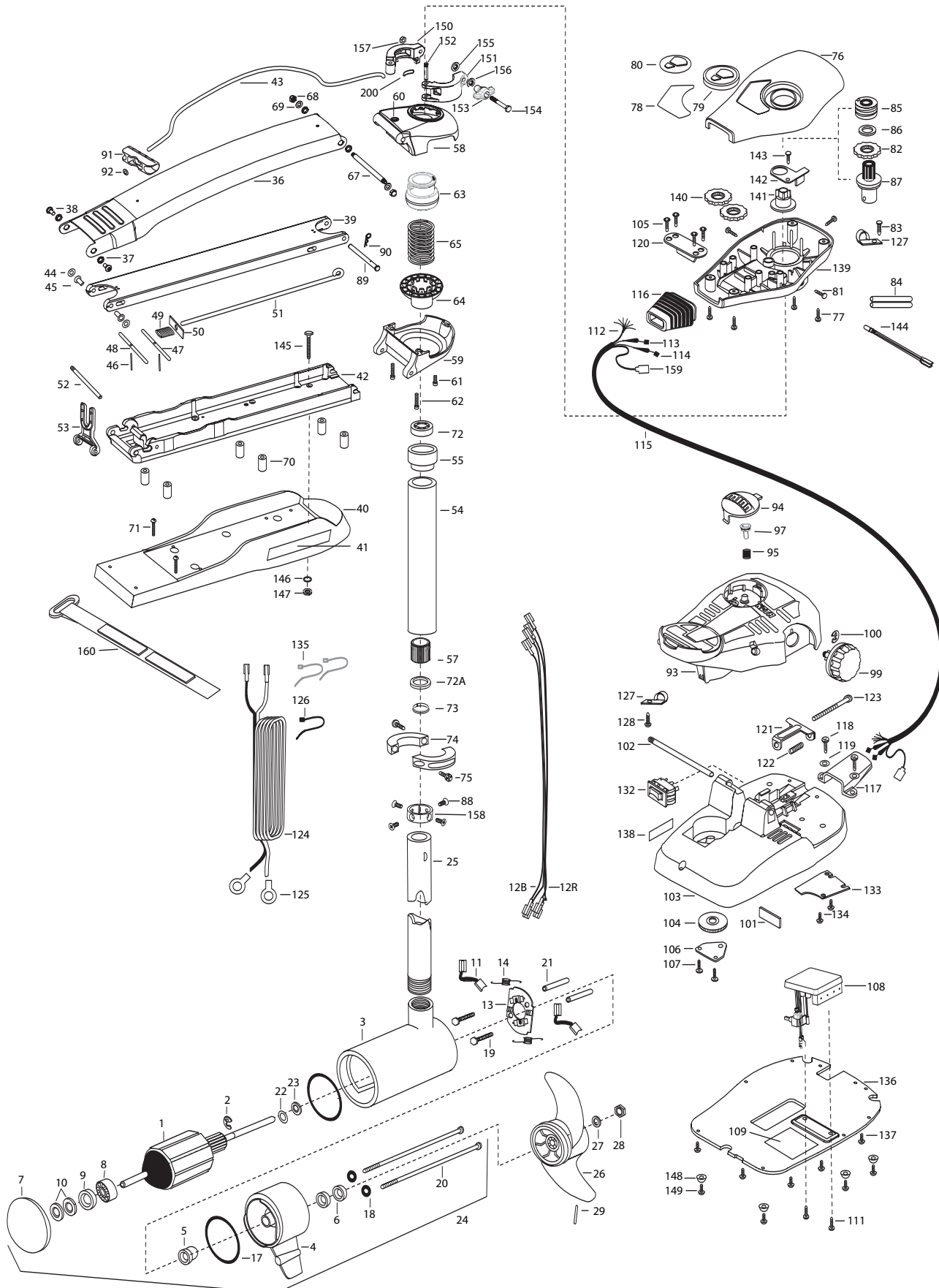

1	2-100-214	ARMATURE ASSEMBLY 24V 4"	64	2071535	SPRING SLEEVE, LOWER	125	2020700	TERMINAL RING, 3/8 [2.EA]
2	788-040	RETAINING RING	65	2262711	SPRING, BOWGUARD, FC PAINTED	126	2256300	TIE WRAP-5.5 BLACK
3	431-160	CENTER HOUSING ASSEMBLY 4.0 TXT	67	2262605	PIN- THREADED	127	2263201	CLAMP WIRE HARNESS MICRO [2.EA]
4	2-300-160	BRUSH END HOUSING ASSEMBLY	68	2223100	NUT - NYLOCK SS [2.EA]	128	2332103	SCREW-6-20 X 3/8 THD SS
5	144-017	BEARING- FLANGE (SERVICE ONLY)	69	2261722	WASHER [2.EA]	132	2254031	SWITCH-MOM/OFF/CON
6	880-025	**SEAL [2.EA]	■	2994832	BAG ASSEMBLY	133	2266412	SWITCH PLATE, PT PEDAL
7	421-276	PLAIN END HOUSING ASSEMBLY	*70	2261505	SPACER, MOTOR REST [6.EA]	134	2332103	SCREW-6-20 X 3/8 THD SS [2.EA]
8	140-010	BALL BEARING	*71	2263434	SCREW, 8-18 X 1 PPH SS [2.EA]	135	2256301	TIE WRAP-5.5 WHITE [2.EA]
9	990-045	THRUST SPACER	72	2266000	BEARING, BALL-STEEL	136	2264511	BOTTOM PLATE, MAXXUM PT
10	992-010	SPRING WASHER [2.EA]	72A	2266116	BEARING, CARTRIDGE	137	2372100	SCREW-8 X 1/2 SS [5.EA]
11	186-094	BRUSH [2.EA]	73	2266001	BEARING, SPLIT RING	138	2266610	DECAL-ON/OFF SWITCH
12B	640-024	LEADWIRE-BLACK 10 AWG 79"	74	2261622	COLLAR HALF-PAINTED-2 PER- KIT	139	2262535	CONTROL BOX-PLASTIC
12R	640-131	LEADWIRE-RED 10 AWG 80 1/2"	75	2263453	SCREW-1/4-20 X 3/4 SHCS SS [2.EA]	140	2267800	GEAR-INDICATOR [2.EA]
13	738-040	BRUSH PLATE 4"	76	2260283	CONTROL BOX COVER-MAXXUM	141	2262220	INDICATOR-DRIVE
14	975-041	SPRING- TORSION [2.EA]	77	2372100	SCREW-8-18 X 5/8 THD [4.EA]	142	2261905	BRACKET/INDICATOR
17	701-009	**O-RING —THRU BOLT [2.EA]	78	2265644	DECAL COVER, MAXXUM 80	143	2301310	SCREW-8-18 X 1/2 SS
18	701-043	**O-RING [2.EA]	79	2260150	POINTER DISC TRNSLCNT RED	144	2264015	LIGHT/INDICATOR
19	830-027	SCREW -SELF THREAD 10-32X2 [2.EA]	80	2265800	DECAL-INDICATOR	■	2994830	BAG ASSEMBLY-MAXXUM
20	830-094	THRU BOLT 12-24X10.31 [2.EA]	81	2053414	SCREW-#8-32 X 1/2 TRI-LOBE [3.EA]	*145	2263431	SCREW 1/4-20 X 3.5 PPH [6.EA]
21	973-025	SPACER- BRUSH PLATE [2.EA]	82	2267800	GEAR-INDICATOR	*146	2261713	WASHER-1/4 FLAT S/S [6.EA]
22	990-051	WASHER- STEEL	83	2301310	SCREW-8-18 X 1/2 SS	*147	2263103	NUT-1/4-20 NYLOCK-JAM [6.EA]
23	990-052	WASHER- NYLATRON	84	2355410	SHRINK TUBE-3/8 OD X 2- [2.EA]	148	2265126	BUMPER [4.EA]
24	2316229	MOTOR ASSEMBLY 24V 4" VARS TXT 62"	85	2232360	PULLEY-CABLE DRUM	149	2263455	SCREW #12 [4.EA]
25	2032008	TUBE COMP W/4 HOLE 72"	86	2261730	WASHER-NYLON	■	2991550	CLAMP COLLAR ASSEMBLY
■	1378132	PROPELLER KIT	87	2996247	PINION/RACE ASSEMBLY	150	2071550	CLAMP COLLAR "A"
26	2331160	PROPELLER W.WEDGE 2	88	2223468	SCREW-8-32 X 7/16 ZN PL [4.EA]	151	2071555	CLAMP COLLAR "B"
27	2091701	WASHER-PROP LARGE	89	2262607	PIN- CLEVIS ZN	152	2072621	PIN-KNURLED
28	2093101	NUT-PROP NYLOCK SS	90	2260805	SPRING CLIP ZN	153	2070120	KNOB-CLAMP COLLAR
29	2262658	PIN-DRIVE SS	91	2150400	PULL-GRIP	154	2073412	SCREW 1/4-28 X 2 3/4" SS
■	2991842	MOUNT,BOW ASSEMBLY, FW W/O BG	92	2151700	WASHER-EYE SHAFT .562 OD	155	2071718	WASHER #10 NYLON RETAINING
36	2264246	ARM UPPER-FW LONG	93	2790002	FOOT PEDAL/PLUG ASSEMBLY	156	2071716	WASHER - FLAT SS
37	2293501	BUSHING, STAINLESS STEEL [4.EA]	94	2993702	PUSH BUTTON / MAGNET ASSEMBLY	157	2073102	NUT - HEX 1/4 - 28 SS
38	2263500	BOLT, SHOULDER MAXXUM [2.EA]	95	2302732	SPRING-LOWER PEDAL SS	158	2071560	SPLIT COLLAR
39	2774317	ARM-LOWER ASSEMBLY,LG,FW,EXT	97	2260810	CLIP, REED SWITCH	160	2263804	STRAP - VELCRO 30.5"
40	2263913	MOTOR REST LONG MAXXUM	99	2260160	KNOB-SPEED CONTROL VAR	200	2075120	URETHANE PAD
41	2265514	DECAL-MAXXUM,MOTOR REST [2.EA]	100	2263000	E-RING TRU-ARC#5133-43			
42	2773986	BOWPLATE- FW LG MACH/INSERT	101	2266413	PLATE -TENSION SCREW FTPED.			
43	2251601	ROPE 40" MAXXUM MOUNT	102	2260511	PIN-PIVOT A/T PT PDL			
44	2261708	WASHER-3/8X1/2X.010 SS [2.EA]	103	2774550	FT PEDAL BASE/PIN ASSEMBLY			
45	2236000	BEARING NYLINER- [2.EA]	104	2262301	PULLEY- FOOT PEDAL			
46	2152610	SPRING-PIN LOCKBAR [2.EA]	105	2223430	SCREW #8X3/4 PPH TYPE 25 SS [4.EA]			
47	2233600	LOCK BAR- BOW MOUNT	106	2266400	COVER-PULLEY STAMPING			
48	2233602	LOCK BAR- REAR ZINC	107	2301310	SCREW-8-18 X 1/2 SS [2.EA]			
49	2152700	SPRING-LOCKBAR CAD.PLT	108	2264052	CONTROL BOARD ASSEMBLY 24V MAX			
50	2262703	SPRING STOP	109	2365107	INSULATING PAD 2.3 X 3.2			
51	2153604	EYE SHAFT-2LOCKBAR LG-PLTD	111	2223455	SCREW, 10-32 X 1/2 [2.EA]			
52	2260506	HINGE-PIN HEADLESS ZINC	112	2261221	WIRE HARNESS AT & MAX 82.5			
53	2293811	YOKE,MAX MNT-POLYPROPYLENE	113	2267506	CABLE ASSEMBLY-RIGHT 8'			
■	2772087	TUBE W/ 4 HOLES 34"	114	2267516	CABLE ASSEMBLY-LEFT 8'			
54	2272087	TUBE OUTER 34"	115	2265432	CABLE JACKET 8'			
55	2266260	BEARING RACE-(565T)	116	2265110	BOOT-CONTROL BOX			
57	2267307	BUSHING, OUTER TUBE	117	2265115	BOOT-FOOT PEDAL BASE			
■	2991759	BOWGUARD ASSEMBLY-FT CTRL,MAX 72	118	2372100	SCREW-8-18 X 5/8 THD SS [2.EA]			
58	2772319	BRACKET BASE TOP/EYELET ASSEMBLY	119	2261714	WASHER-MAXXUM PT PDL [2.EA]			
59	2991770	BRKT BOTTOM/BEARING FW ASSEMBLY	120	2261901	BRACKET-CONDUIT AT/MAX			
60	2772352	EYELET KIT -ROPE	121	2263210	BRACKET-CONDUIT ADJUSTMENT			
61	2263423	SCREW 5/16-18 X 1" SHCS	122	2262720	SPRING-CONDUIT AD			
62	2263425	SCREW 5/16-18 X 2-1/2 SHCS [2.EA]	123	2263466	SCREW-1/4-20 X 2 STL PPH			
63	2071541	SPRING-SLEEVE UPPER	124	2261233	LEADWIRE VARIABLE			

\*\* Seal & Oring Kit P/N 2889460

\* This item is part of an assembly. This item cannot be sold separately due to machining and/or assembly that is required.

P/N 2274969 REV. F 6-05

