

MAXXUM PRO 101 FC
101 LBS THRUST
36 VOLT 46 AMPS
42" SHAFT

for use with "AG" serial numbers
3-year warranty from the date of purchase

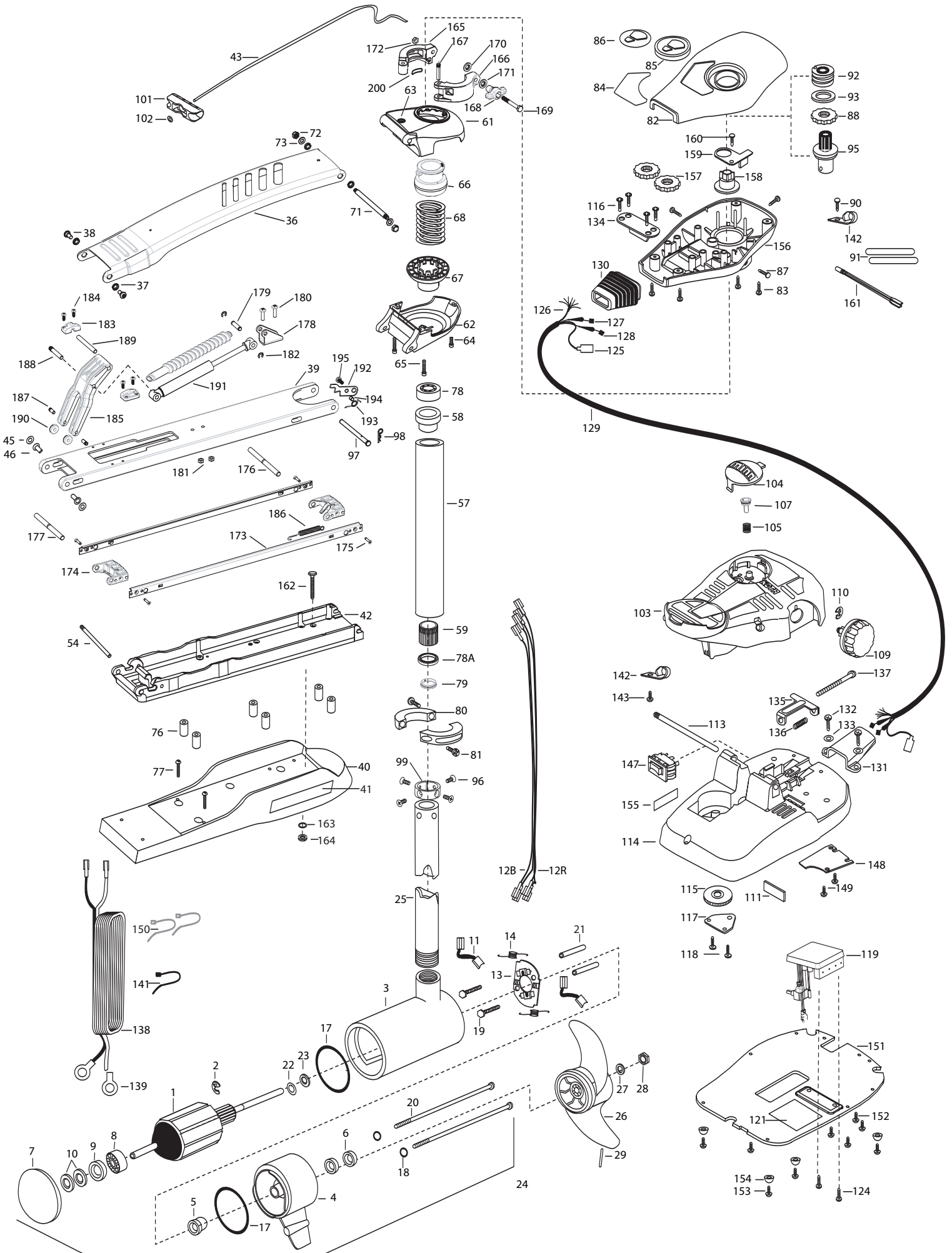

1	2-100-216	ARMATURE ASSEMBLY 36V 4"	72	2223100	NUT- NYLON [2.EA]	139	2020700	TERMINAL RING, 3/8 [2.EA]
2	788-040	RETAINING RING	73	2261722	WASHER [2.EA]	141	2256300	TIE WRAP-5.5 BLACK
3	2-200-110	HOUSING ASSEMBLY CENTER 4.0	■	2994832	BAG ASSEMBLY	142	2263201	CLAMP WIRE HARNESS MICRO [2.EA]
	2-200-120	HOUSING ASSEMBLY CENTER 4.0- SONAR	*76	2261505	SPACER, MOTOR REST [6.EA]	143	2332103	SCREW-6-20 X 3/8 THD SS
4	2-300-160	BRUSH END HOUSING ASSEMBLY	*77	2263434	SCREW, 8-18 X 1 PPH SS [2.EA]	147	2254031	SWITCH-MOM/OFF/COM
5	144-017	BEARING- FLANGE (SERVICE ONLY)	78	2266000	BEARING, BALL-STEEL	148	2266412	SWITCH PLATE, PT PEDAL
6	880-025	**SEAL [2.EA]	78A	2266001	BEARING, CARTRIDGE	149	2332103	SCREW-6-20 X 3/8 THD SS [2.EA]
7	9421-279	PLAIN END HOUSING ASSEMBLY- SONAR	79	2266116	BEARING, SPLIT RING	150	2256301	TIE WRAP-5.5 WHITE [2.EA]
	421-276	PLAIN END HOUSING ASSEMBLY	80	2771617	COLLAR HALF-ZINC-2 PER- KIT	151	2264511	BOTTOM PLATE, MAXXUM PT
8	140-010	BALL BEARING	81	2263452	SCREW-1/4-20 X 3/4 SHCS SS [2.EA]	152	9953104	SCREW-8 X 1/2 PPH SS [5.EA]
9	990-045	THRUST SPACER	82	2260283	CONTROL BOX COVER-MAXXUM	153	2263455	SCREW #12 [4.EA]
10	992-010	SPRING WASHER [2.EA]	83	2372100	SCREW-8-18 X 5/8 THD [4.EA]	154	2265126	BUMPER [4.EA]
11	186-094	BRUSH [2.EA]	84	2265642	DECAL COVER, MAXXUM 101	155	2266610	DECAL-ON/OFF SWITCH
12B	640-014	BRUSH LEAD BLK 10 AWG 51-1/2		2265649	DECAL COVER, MAXXUM 101-SONAR	156	2262535	CONTROL BOX-PLASTIC AT'S
12R	640-118	BRUSH LEAD RED 10 AWG 53	85	2260150	POINTER DISC TRNSLCNT RED	157	2267800	GEAR-INDICATOR [2.EA]
13	738-004	BRUSH PLATE 4"	86	2265800	DECAL-INDICATOR	158	2262220	INDICATOR-DRIVE
14	975-041	SPRING- TORSION [2.EA]	87	2053414	SCREW-#8-32 X 1/2 TRI-LOBE [3.EA]	159	2261905	BRACKET/INDICATOR
17	701-043	**O-RING [2.EA]	88	2267800	GEAR-INDICATOR	160	2301310	SCREW-8-18 X 1/2 SS
18	701-009	**O-RING —THRU BOLT [2.EA]	90	2301310	SCREW-8-18 X 1/2 SS	161	2264015	LIGHT/INDICATOR
19	830-027	SCREW -SELF THREAD 10-32X2 [2.EA]	91	2355410	SHRINK TUBE 3/8 OD X 2- [2.EA]	■	2994830	BAG ASSEMBLY-MAXXUM
20	830-094	THRU BOLT 12-24X10.31 [2.EA]	92	2232360	PULLEY-CABLE DRUM	*162	2263431	SCREW 1/4-20 X 3.5 PPH [6.EA]
21	973-025	SPACER- BRUSH PLATE [2.EA]	93	2261730	WASHER-NYLON	*163	2261713	WASHER-1/4 FLAT S/S [6.EA]
22	990-051	WASHER- STEEL	95	2996247	PINION/RACE ASSEMBLY	*164	2263103	NUT-1/4-20 NYLOCK-JAM [6.EA]
23	990-052	WASHER- NYLATRON	96	2223468	SCREW-8-32 X 7/16 ZN PL [4.EA]	■	2991550	CLAMP COLLAR ASSEMBLY
24	2316280	MOTOR ASSEMBLY 36V 4" VARS	97	2262607	PIN- CLEVIS ZP	165	2071550	CLAMP COLLAR "A"
	2326280	MOTOR ASSEMBLY 36V 4" VARS- SONAR	98	2260800	SPRING CLIP SS	166	2071555	CLAMP COLLAR "B"
25	2032003	TUBE COMP W/4 HOLE 42"	99	2071560	SPLIT COLLAR	167	2072621	PIN-KNURLED
■	1378132	PROPELLER KIT	101	2150400	GULL-GRIP	168	2070120	KNOB-CLAMP COLLAR
26	2331160	PROPELLER W.WEDGE 2	102	2151700	WASHER-EYE SHAFT .562 OD	169	2073412	SCREW 1/4-28 X 2 3/4" SS
27	2091701	WASHER-PROP LARGE	103	2790002	FOOT PEDAL/PLUG ASSEMBLY	170	2071718	WASHER #10 NYLON RETAINING
28	2093101	NUT-PROP NYLOCK SS	104	2993702	PUSH-BUTTON MAGNET ASSEMBLY	171	2071716	WASHER - FLAT SS
29	2262658	PIN-DRIVE SS	105	2302732	SPRING-LOWER PEDAL SS	172	2073102	NUT - HEX 1/4 - 28 SS
■	2991740	MOUNT,BOW ASSEMBLY, FW STD W/BG	107	2260810	CLIP, REED SWITCH	173	2263610	TIE RAIL SHORT [2 EA.]
36	2264250	ARM UPPER-FW STD	109	2260160	KNOB-SPEED CONTROL VAR	174	2262645	LATCH PIN HOLDER [2 EA.]
37	2293501	BUSHING, STAINLESS STEEL [4.EA]	110	2263000	E-RING TRU-ARC#5133-43	175	2263456	SCREW #8 - 3/4" BTFH SS [4 EA.]
38	2263500	BOLT, SHOULDER MAXXUM [2.EA]	*111	2266413	PLATE -TENSION SCREW FTPEL.	176	2262661	LATCH PIN, GROOVED FRONT SS
■	2774331	LOWER ARM ASSEMBLY,STD,FW,101#	113	2260511	PIN-PIVOT A/T PT PDL	177	2262663	LATCH PIN, GROOVED REAR SS
39	2264330	ARM-LOWER ASSEMBLY,STD,FW,EXT	114	2774550	FT PEDAL BASE/PIN ASSEMBLY	178	2261990	BRACKET, CYLINDER FRONT
40	2263912	MOTOR REST STD MAXXUM	115	2262301	PULLEY- FOOT PEDAL	179	2262665	PIN, FRONT SHOCK MOUNT
41	2265508	DECAL-MAXXUM,MOTOR REST [2.EA]	116	2223430	SCREW- 8X3/4 PPH TYPE 25 SS [4.EA]	180	2332104	SCREW 1/4-20 X 5/8" PH SS [2 EA.]
42	2773987	BOWPLATE- FW STD MACH/INSERT	117	2266400	COVER-PULLEY STAMPING	181	2073100	1/4-20" NUT SS [2 EA.]
43	2251601	ROPE 40" MAXXUM MOUNT	118	2301310	SCREW-8-18 X 1/2 SS [2.EA]	182	2263006	E-CLIP 5/16" SHAFT SS [2 EA.]
45	2261708	WASHER-3/8X1/2X.016 [2.EA]	119	2264052	CONTROL BOARD ASSEMBLY 24V MAX	183	2261995	BRACKET- REAR [2 EA.]
46	2236000	BEARING NYLINER- [2.EA]	121	2365107	INSULATING PAD 2.3 X 3.2	184	2223454	SCREW #10-32 X 1/2" PH SS [4 EA.]
54	2260506	HINGE-PIN HEADLESS ZINC	124	2263455	SCREW, 10-32 X 1/2 [2.EA]	185	2261545	YOKE-GAS ASSIST
■	2772085	TUBE W/BEARING RACE ASSEMBLY 42"	125	2211400	EXTENSION CABLE- SONAR	186	2262722	SPRING EXTENSION
57	2272085	TUBE -OUTER 21" 4 HOLES [FOR 42"]	126	2261220	WIRE HARNESS AT & MAX 82.5	187	2262635	PIN ROLLER SS [2 EA.]
58	2266260	BEARING RACE-(565T)	127	2267505	CABLE ASSEMBLY-RIGHT 5'	188	2262667	PIN-KNURLED SS
59	2267307	BUSHING, OUTER TUBE	128	2267515	CABLE ASSEMBLY-LEFT 5'	189	2262669	PIN-YOKE PIVOT SS
■	2991763	BOWGUARD ASSEMBLY-FT CTRL,MAX	129	2265430	CABLE JACKET 5'	190	2262320	ROLLER YOKE [2 EA.]
61	2772319	BRACKET BASE TOP/EYELETASSEMBLY	130	2265110	BOOT-CONTROL BOX	191	2998429	CYLINDER/SHOCK BOOT ASSEMBLY
62	2991770	BRKT BOTTOM/BEARING FW ASSEMBLY	131	2265115	BOOT-FOOT PEDAL BASE	192	2262670	LATCH PIN STOP LEVER
63	2262315	EYELET KIT -ROPE	132	2372100	SCREW-8-18 X 5/8 THD SS [2.EA]	193	2262723	SPRING, MAXXUM PRO
64	2263423	SCREW 5/16-18 X 1 SHCS	133	2261714	WASHER-MAXXUM PT PDL [2.EA]	194	2301700	SPACER-RELEASE LEVER BRASS
65	2263425	SCREW 5/15-18 X 2-1/2 SHCS [2.EA]	134	2261901	BRACKET-CONDUIT AT/MAX	195	2332104	SCREW 1/4-20 X 5/8" SS
66	2071541	SPRING-SLEEVE UPPER	135	2263210	BRACKET-CONDUIT ADJUSTMENT	200	2075120	URETHANE PAD
67	2071535	SPRING SLEEVE, LOWER	136	2262720	SPRING-CONDUIT			
68	2262712	SPRING, BOWGUARD, NIK PL	137	2263463	SCREW-1/4-20 X 2 STL PPH			
71	2262605	PIN- THREADED ZP	138	2261233	LEADWIRE VARIABLE			

