

MAXXUM 55T
55 LBS. THRUST
12 VOLT 50 AMPS
42" OR 36" SHAFT

for use with "AG" serial numbers
3-year warranty from the date of purchase

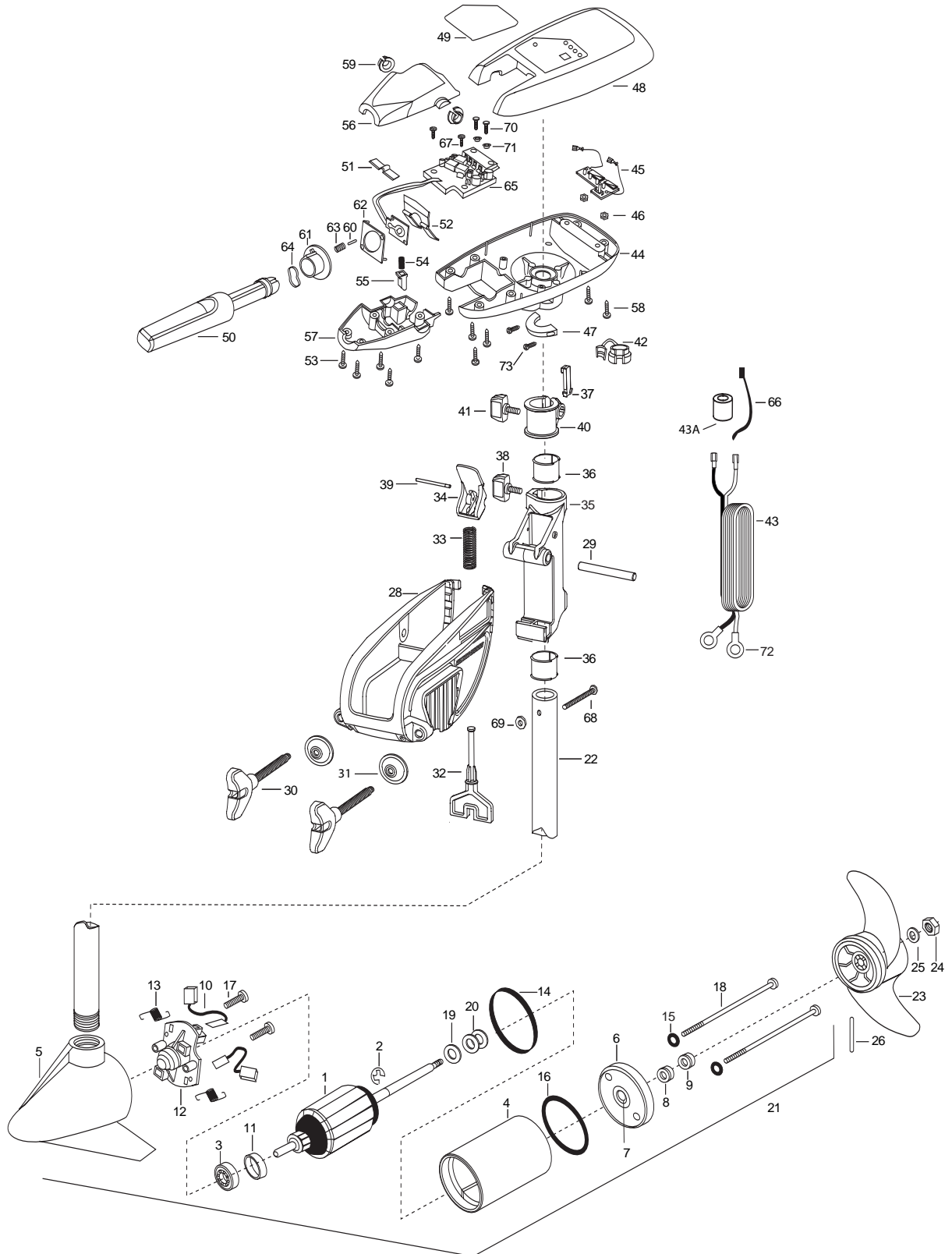

1	2-100-115	ARMATURE ASSEMBLY 12V F/W	36	2037301	BUSHING-HINGE [2.EA]
2	788-015	RETAINING RING	37	2062800	TENSION BLOCK-SNAP IN
3	140-010	BEARING -BALL	38	2011385	SCREW, TENSION/KNOB
4	431-101	HOUSING ASSEMBLY CENTER 3.62	39	2060515	PIN, TILT LEVER
5	421-065	HOUSING BRUSH END ASSEMBLY 3.62 TXT	40	2061520	COLLAR-DEPTH
6	2-400-101	PLAIN END HOUSING ASSEMBLY	41	2011365	SCREW-COLLAR/NEW
7	144-049	FLANGE BEARING (SERVICE ONLY)	42	2052900	STRAIN RELIEF C CORD/SP.C
8	880-003	**SEAL	43	2090600	LEADWIRE (10 GA) RINGS
9	880-006	**SEAL W/SHIELD	43A	2307310	BEAD - FERRITE (CE MODELS ONLY)
10	188-036	BRUSH ASSEMBLY	44	2062592	CONTROL BOX,FW, .725 BORE,
11	725-050	PAPER TUBE- BRUSH RETENTION	45	2074703	BATTERY GAUGE-12 VOLTS
12	738-036	BRUSH PLATE W/HOLDER	46	2303120	SPEED NUT [2.EA]
13	975-040	SPRING -TORSION [2.EA]	47	2061515	COLLAR-CTRL BOX (FRS-WTR)
14	337-036	**GASKET	48	2990294	CTRL BOX CVR/DECAL ASSEMBLY
15	701-008	**O-RING -THRU BOLT [2.EA]	49	2065663	DECAL-COVER MAX 55/T
16	701-081	**O-RING	50	2990914	HANDLE ASSEMBLY W/O U-JOINT
17	830-007	SCREW 8-32X1 [2.EA]	51	2302742	SPRING-DETENT (OFF) SS
18	830-042	THRU BOLT 10-32X8.83 (2 EA)	52	2302743	SPRING-DETENT (HANDLE-TILT
19	990-067	WASHER -STEEL THRUST	53	2303412	SCREW-6-20 X 5/8 SELF TAP [6.EA]
20	990-070	WASHER -NYLATRON [2.EA]	54	2302745	SPRING-RELEASE BUTTON SS
21	2097094	MOTOR ASSEMBLY -12V 3.625 F/W VARS TXT	55	2303720	RELEASE BUTTON-HANDLE
22	2032052	TUBE (COMPOSITE) 36"	56	2060409	HANDLE (TOP HALF) MAXIMIZE
	2032053	TUBE (COMPOSITE) 42"	57	2060415	HANDLE (LOWER HALF)
■	1378131	PROPELLER KIT	58	2303412	SCREW-6-20 X 5/8 SELF TAP [5.EA]
23	2091160	PROPELLER- WEEDLESS WEDGE 2	59	2060005	BEARING-HANDLE PIVOT [2.EA]
24	2151726	WASHER- 5/16 STD SS	60	2302600	PIN-ACTUATOR
25	2053101	NUT-PROP NYLOC 5/16 SS	61	2302850	ACTUATOR-CAM
26	2092600	PIN-DRIVE SS	62	2302851	ACTUATOR-FWD/REV
■	2771818	BRACKET & HINGE ASSEMBLY (INCLUDES- 28—39)	63	2302740	SPRING- (ACTUATOR)
■	2771910	BRACKET ASSEMBLY (INCLUDES- 28,30,31)	64	2302741	SPRING-CAM (ZNC PLTD STEEL)
*28	2061910	BRACKET- PLASTIC	65	2334006	CONTROL BOARD W/O LEAD 12V
29	2060510	PIN-HINGE	66	2256300	TIE WRAP-5.5 BLACK
■	2881300	SCREW-CLAMP, WASHER, RETAINER KIT [2.EA]	67	2372100	SCREW-8-18 X 5/8 THD SS [2.EA]
*30	2061300	SCREW-CLAMP [2.EA]	68	2383407	SCREW-10-24 X 2 PPH ZINC
*31	2011710	WASHER-CLAMP SCREW [2.EA]	69	2383124	NUT-10-24 NYLOCK ZINC
32	2063605	T-BAR, PLASTIC	70	2301310	SCREW-8-18 X 1/2 SS [2.EA]
33	2062706	SPRING- (T-BAR)	71	2301710	WASHER-INSUL. (TRANSF.BAR) [2.EA]
34	2067200	LEVER-TILT (RED)	72	2020700	TERMINAL- RING 3/8 [2.EA]
35	2061810	HINGE-PLASTIC	73	2263434	SCREW #8 X 1" PPH SS [2.EA]

** Seal & Oring Kit P/N 2888460 * This item is part of an assembly. This item cannot be sold separately due to machining and /or assembly that is required.

P/N 2064945 REV. B 4-05

