

MAXXUM 101
101 lbs Thrust
36 Volt 46 Amps
52 & 62" SHAFT

for use with "AH" serial numbers
3-year warranty from the date of purchase

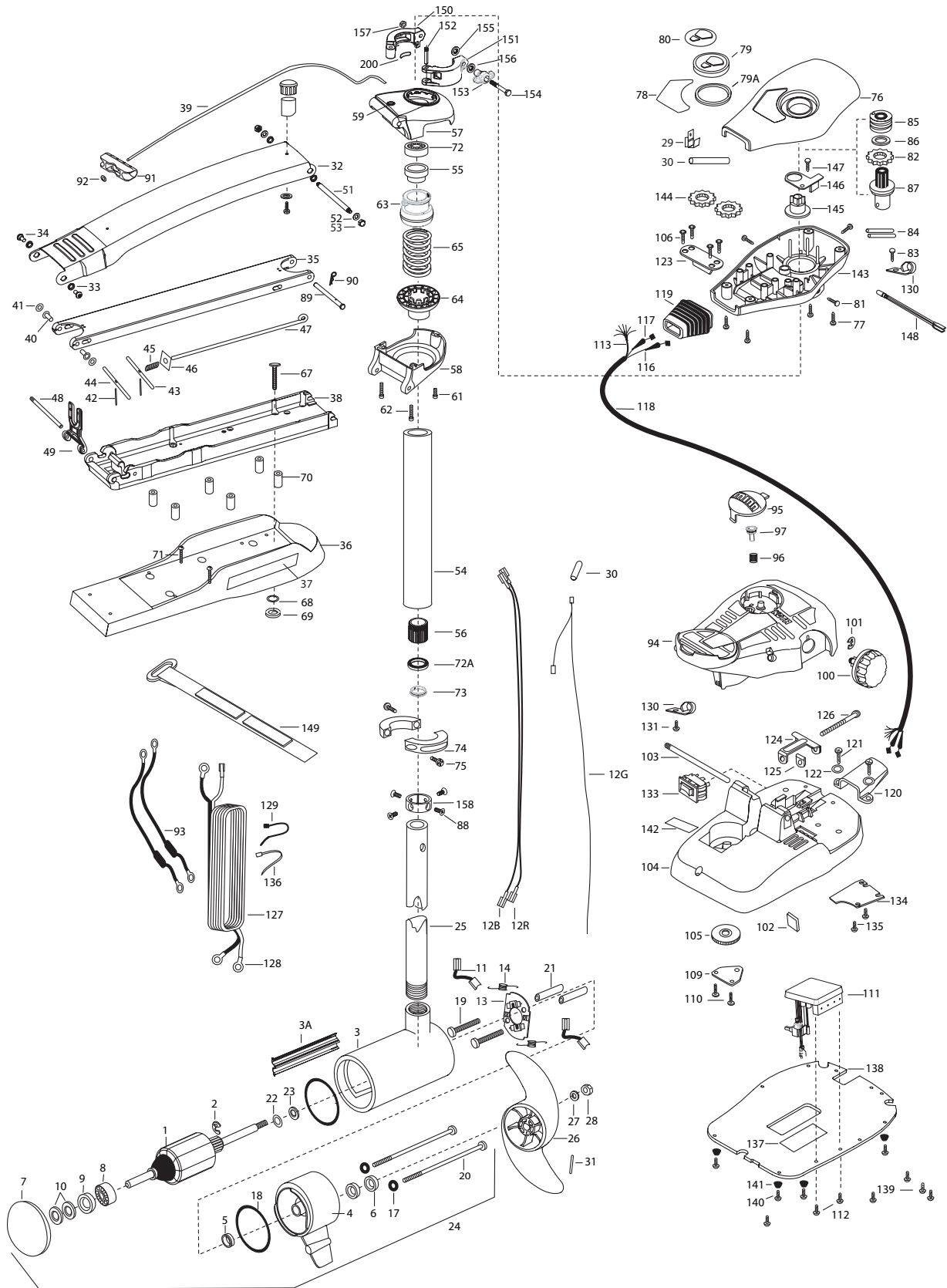

1	2-100-216	ARMATURE ASSEMBLY 36V 4 VARS FW 101#	49	2293811	YOKE, MAXXUM MOUNT POLYPROPYLENE	103	2260511	PIN-PIVOT A/T FT PDL
2	788-040	RETAINING RING	■	2994841	BAG ASSEMBLY- MAXXUM STABILIZER	104	2992102	FOOT PEDAL BASE/PIN ASSEMBLY
3	2-200-110	CENTER HOUSING ASSEMBLY 4.0 FW TXT MAX	51	2262605	PIN- BWGRD UPPER THREADED ZP	105	2262301	PULLEY FOOT PEDAL
3A	582-014	CLIP, RETAINING, US2	52	2261722	WASHER FLAT [2.EA]	106	2223430	SCREW- #8 X3/4" PPH TYPE 25 SS [4.EA]
4	2-300-160	BRUSH END HOUSING ASSEMBLY 4.0 FW TXT	53	2223100	NUT-TENSION 5/16-18 SS [2.EA]	109	2266401	COVER-PULLEY STAMPING
5	144-017	BEARING -FLANGE (SERVICE ONLY)	■	2772086	TUBE W/BEARING RACE ASSEMBLY 52"	110	2301310	SCREW-8-18 X 1/2" SS [2.EA]
6	880-025	SEAL [2.EA]		2772087	TUBE W/BEARING RACE ASSEMBLY 62"	111	2344054	CONTROL BOARD ASSEMBLY- MAX101
7	421-276	PLAIN END HOUSING ASSEMBLY 4.0	54	2272086	TUBE OUTER -24" 4 HOLES 52"	112	2263455	SCREW 10-32 X 1/2 [2.EA]
	9421-285	PLAIN END HOUSING ASSEMBLY 4.0 US2 52"		2272087	TUBE OUTER -34" 4 HOLES 62"	113	2261220	WIRE HARNESS MAX 101
	9421-286	PLAIN END HOUSING ASSEMBLY 4.0 US2 62"	55	2266260	BEARING RACE- 565T	116	2267505	CABLE ASSEMBLY-RIGHT 5'
8	140-010	BALL BEARING	56	2267307	BUSHING, OUTER TUBE	117	2267515	CABLE ASSEMBLY-LEFT 5'
9	990-045	THRUST SPACER	■	2991763	BOWGUARD ASSEMBLY-FT CTRL,MAX	118	2265430	CABLE JACKET 5'
10	992-010	SPRING WASHER	57	2772319	BRACKET BASE TOP/EYELET ASSEMBLY	119	2265110	BOOT-CONTROL BOX
11	188-094	BRUSH 4"W/TERMINAL [2.EA]	58	2771770	BRACKET BOTTOM/BEARING ASSEMBLY	120	2265115	BOOT-FOOT PEDAL BASE
12B	640-024	BRUSH WIRE- BLACK 10 AWG 79"	59	2772352	EYELET-ROPE KIT	121	2372100	SCREW-8-18 X 5/8",THDT [2.EA]
12R	640-131	BRUSH WIRE- RED 10 AWG 80-1/2"	61	2263423	SCREW 5/16-18 X 1" SHCS ZINC	122	2261714	WASHER-MAXXUM FT PDL [2.EA]
12G	640-306	GROUND WIRE 52"	62	2263425	SCREW 5/16-18 X 2-1/2" SHCS [2.EA]	123	2261901	BRACKET-CONDUIT AT/MAX
	640-307	GROUND WIRE 62"	63	2071541	SPRING-SLEEVE UPPER	124	2263210	BRACKET-CONDUIT ADJUST
13	738-004	BRUSH PLATE - 4" TERMINAL	64	2071535	SPRING SLEEVE, LOWER	125	2263104	NYLOCK KEEPER
14	975-041	SPRING -TORSION [2.EA]	65	2262706	SPRING, BOWGUARD, NIK	126	2263466	SCREW-1/4-20 X 2" STL PPH
17	701-009	O-RING -THRU BOLT [2.EA]	■	2994830	BAG ASSEMBLY-MAXXUM	127	2261238	LEADWIRE A/T VARIABLE
18	701-043	O-RING (2 REQ'D)	*67	2263431	SCREW 1/4-20 X 3.5" PPH [6.EA]	128	2020700	TERMINAL RING, 3/8" [2.EA]
19	830-027	SCREW -SELF TREADED 10-32 X 2" [2.EA]	*68	2261713	WASHER-1/4" FLAT S/S [6.EA]	129	2256300	TIE WRAP-5.5" BLACK
20	830-096	THRU BOLT 12-24 X 11.56" SS [2.EA]	*69	2263103	NUT -NYLOCK JAM 1/4-20 S/S [6.EA]	130	2263201	CLAMP WIRE HARNESS MICRO [2.EA]
21	973-025	SPACER -BRUSH PLATE [2.EA]	■	2994832	BAG ASSEMBLY	131	2332103	SCREW-6-20 X 3/8" THD
22	990-051	WASHER-THRUST, STEEL	70	2261505	SPACER, MOTOR REST [6.EA]	133	2254031	SWITCH-MOM/OFF/COM
23	990-052	WASHER- NYLATRON	71	2263434	SCREW, 8-18 X 1" PPH [2.EA]	134	2266412	SWITCH PLATE, FT PEDAL
24	2316285	MOTOR ASSEMBLY 36V VARS TXT (52")	72	2266000	BEARING, BALL-STEEL	135	2332103	SCREW-6-20 X 3/8" THD [2.EA]
	2316289	MOTOR ASSEMBLY 36V VARS TXT (62")	72A	2266116	BEARING, CARTRIDGE	136	2256301	TIE WRAP-5.5" WHITE [2.EA]
	2326286	MOTOR ASSEMBLY 36V VARS TXT US2 (52")	73	2266001	BEARING, SPLIT RING	137	2365107	INSULATING PAD 2.3 X 3.2"
	2326287	MOTOR ASSEMBLY 36V 4" VARS US2 (62")	74	2261619	COLLAR HALF-ZINC-2 PER	138	2264511	BOTTOM PLATE, MAX 101
25	2032006	TUBE (COMP) W/4 HOLE 52"	75	2263452	SCREW- 1/4-20X3/4 SHCP SS [2.EA]	139	2372100	SCREW-8 X 5/8" SS [5.EA]
	2032007	TUBE (COMP) W/4 HOLE 62"	76	2260283	CONTROL BOX COVER-MAX	140	2263455	SCREW #12-14 X 1/2" THR FRM [4.EA]
■	1378132	PROPELLER KIT	77	2372100	SCREW-8-18 X 5/8" THDT [4.EA]	141	2265126	BUMPER PAD, FOOT PEDAL [4.EA]
26	2331160	PROPELLER (W.WEDGE 2)	78	2265663	DECAL COVER, MAXXUM 101	142	2266610	DECAL-ON/OFF SWITCH
27	2091701	WASHER-PROP (LARGE) MAX 101		2265651	DECAL COVER, MAXXUM 101/SONAR	143	2262535	CONTROL BOX-PLASTIC
28	2093101	NUT-PROP (LARGE) MAX 101	79	2260150	POINTER DISC TRNSLCNT	144	2267800	GEAR-INDICATOR [2.EA]
29	2020713	TERMINAL- ADAPTOR MAX50/S	79A	2261733	WASHER-FOAM, INDICATOR	145	2262220	INDICATOR-DRIVE
30	2335400	SHRINK TUBE 1/4ODX2" [2.EA.]	80	2265800	DECAL-INDICATOR	146	2261905	BRACKET/INDICATOR
31	2262658	PROP PIN	81	2053414	SCREW-8-32 X 1/2" TRI-LOBE [3.EA]	147	2301310	SCREW-8-18 X 1/2" SS
■	2991841	MOUNT, BOW ASSEMBLY W/O BGRD FW MAX	82	2267800	GEAR INDICATOR	148	2264015	LIGHT/INDICATOR
32	2264246	ARM-UPPER FW LG	83	2301310	SCREW-8-18 X 1/2" SS	149	2263802	STRAP- HOLD DOWN 30.5 VELCRO
33	2293501	BUSHING, STAINLESS STEEL [4.EA]	84	2355410	SHRINK TUBE-3/8 OD X 2" [2.EA]	■	2991550	CLAMP COLLAR ASSEMBLY
34	2263500	BOLT, SHOULDER [2.EA]	85	2232360	PULLEY-CABLE DRUM	150	2071550	CLAMP COLLAR "A"
35	2774317	ARM-LOWER ASSEMBLY, LG, FW EXTR	86	2261730	WASHER-NYLON A/T	151	2071555	CLAMP COLLAR "B"
36	2263913	MOTOR REST LONG, MAXXUM	87	2996247	TOP BEARING RACE /PINION DRIVE ASSEMBLY	152	2072621	PIN-KNURLED
37	2265514	DECAL- MOTOR REST [2.EA]	88	2223468	SCREW-8-32 X 7/16" ZINC PLATE [4.EA]	153	2070120	KNOB-CLAMP COLLAR
38	2773986	BOWPLATE, LG FW /INSERT	89	2262607	PIN - CLEVIS ZP MAX BG	154	2073412	SCREW 1/4-28 X 2 3/4" SS
39	2251601	ROPE 40" MAXXUM	90	2260805	CLIP-SPRING ZP MAX BG	155	2071718	WASHER #10 NYLON RETAINING
41	2261708	WASHER-3/8 X 1/2 X.010" SS [2.EA]	91	2150400	PULL-GRIP	156	2071716	WASHER - FLAT SS
40	2267318	BEARING NYLINER [2.EA]	92	2151700	WASHER-EYE SHAFT .562"	157	2073102	NUT - HEX 1/4 - 28 SS
42	2152610	SPRING-PIN (LOCKBAR) [2.EA]	93	2998200	CIRCUIT BREAKER ASSEMBLY 36V-101 [2.EA]	158	2071560	SPLIT COLLAR
43	2233600	LOCK BAR- (BOW MOUNT)	94	2790002	FOOT PEDAL/PLUG ASSEMBLY	159	2211410	EXTENSION CABLE US2
44	2233602	LOCK BAR, REAR - ZINC	95	2993702	PUSH-BUTTON MAGNET ASSEMBLY	200	2075120	URETHANE PAD
45	2152700	SPRING -LOCKBAR	96	2302732	SPRING-LOWER PEDAL SS			
46	2262703	SPRING STOP	97	2260810	CLIP, REED SWITCH			
47	2153604	EYE SHAFT -2LOCKBAR STD PLTD	100	2260160	KNOB-SPEED CONTROL			
48	2260506	HINGE-PIN HEADLESS ZINC	101	2263000	E-RING TRU-ARC#5133-43			
			102	2266413	TENSION SCREW PLATE FT			

Seal & O-Ring Kit is p/n 2889460

* This item is part of an assembly. This item cannot be sold separately due to machining and /or assembly that is r equired.

P/N2274966 REV. K 11-06

Max 101 is 36-volt!

OPTIONAL BROWN WIRE FOR SONAR EQUIPPED MOTORS.
SEE BOAT WIRING DIAGRAM
FIL MARRON OPTIONNEL POUR MOTEURS
ÉQUIPÉS DE SONAR. VOYEZ LE SCHÉMA DE CÂBLAGE DU BATEAU.

