

MAXXUM 80
80 lbs Thrust
24 volt 56 amps
48", 52" & 62" SHAFT

for use with "AH" serial numbers
3-year warranty from the date of purchase

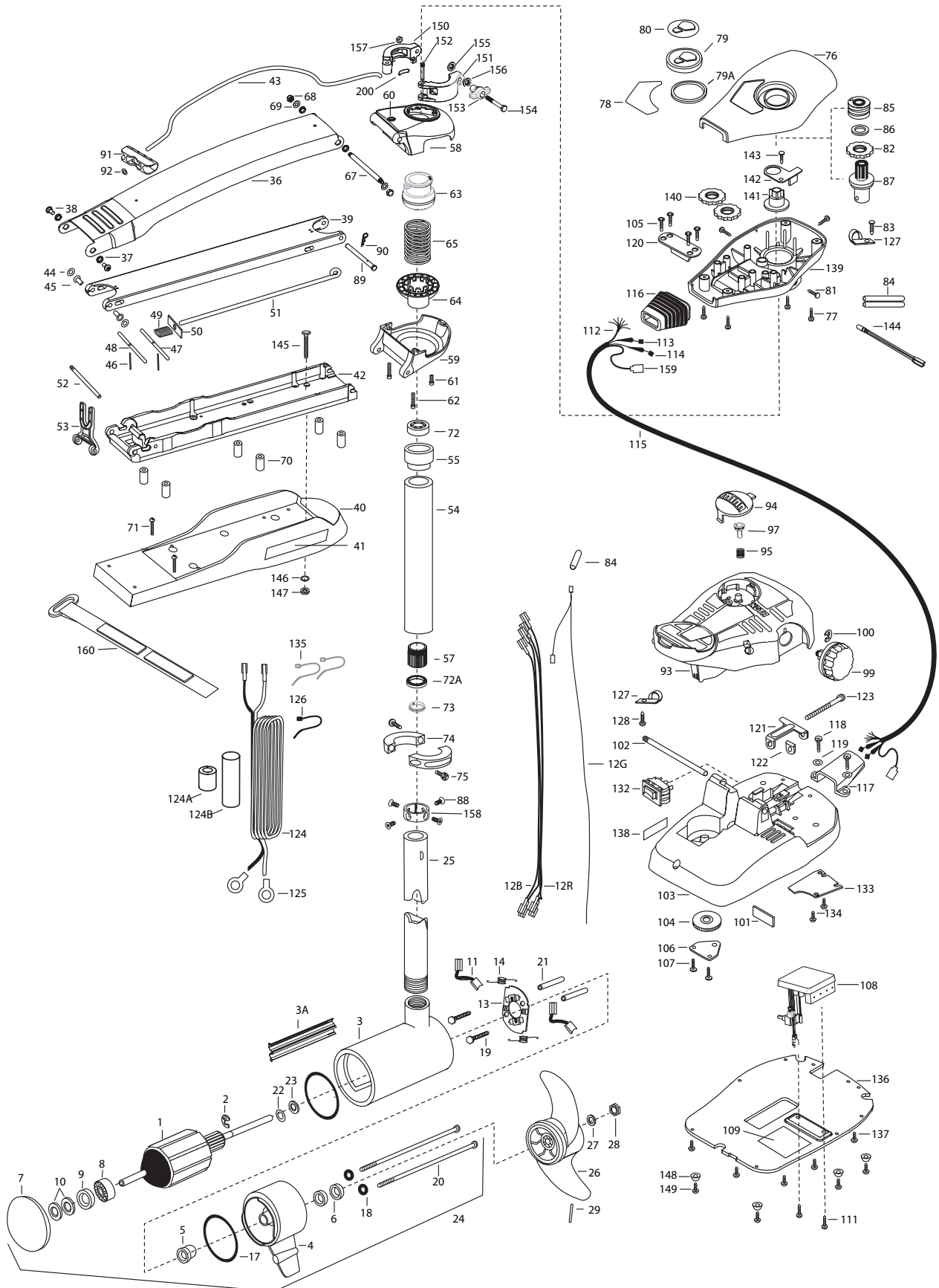

1	2-100-214	ARMATURE ASSEMBLY 24V 4"	52	2260506	HINGE-PIN HEADLESS ZINC	107	2301310	SCREW-8-18 X 1/2 SS [2.EA]
2	788-040	RETAINING RING	53	2293811	YOKE,MAX MNT-POLYPROPYLENE	108	2344054	CONTROL BOARD ASSY 24-36V MAX
3	431-160	CENTER HOUSING ASSEMBLY 4.0 TXT	■	2772087	TUBE W/BEARING RACE ASSEMBLY 34"	109	2365107	INSULATING PAD 2.3 X 3.2
3A	582-013	CLIP, RETAINING, US2		2772086	TUBE W/BEARING RACE ASSEMBLY 24"	111	2263455	SCREW, 10-32 X 1/2 [2.EA]
4	2-300-160	BRUSH END HOUSING ASSEMBLY	54	2272087	TUBE OUTER 34" 62	112	2261220	WIRE HARNESS AT & MAX 82.5
5	144-017	BEARING- FLANGE (SERVICE ONLY)		2272086	TUBE OUTER 24" 48"-52"	113	2267505	CABLE ASSEMBLY-RIGHT 5'
6	880-025	SEAL [2.EA]	55	2266260	BEARING RACE-(565T)	114	2267515	CABLE ASSEMBLY-LEFT 5'
7	421-276	PLAIN END HOUSING ASSEMBLY	57	2267307	BUSHING, OUTER TUBE	115	2265430	CABLE JACKET 5'
	9421-284	PLAIN END HOUSING ASSEMBLY US2 42"	■	2991763	BOWGUARD ASSEMBLY-FT CTRL,MAX 62	116	2265110	BOOT-CONTROL BOX
	9421-285	PLAIN END HOUSING ASSEMBLY US2 52"		2991762	BOWGUARD ASSEMBLY-FT CTRL,MAX 52	117	2265115	BOOT-FOOT PEDAL BASE
	9421-286	PLAIN END HOUSING ASSEMBLY US2 62"	58	2772319	BRACKET BASE TOP/EYELET ASSEMBLY	118	2372100	SCREW-8-18 X 5/8 THD SS [2.EA]
8	140-010	BALL BEARING	59	2991770	BRKT BOTTOM/BEARING FW ASSEMBLY 62	119	2261714	WASHER-MAXXUM PT PDL [2.EA]
9	990-045	THRUST WASHER		2991771	BRKT BOTTOM/BEARING FW ASSEMBLY 52	120	2261901	BRACKET-CONDUIT AT/MAX
10	992-010	SPRING WASHER [2.EA]	60	2772352	EYELET KIT -ROPE	121	2263210	BRACKET-CONDUIT ADJUSTMENT
11	186-094	BRUSH [2.EA]	61	2263423	SCREW 5/16-18 X 1" SHCS ZINC	122	2263104	NYLOCK KEEPER
12B	640-024	LEADWIRE-BLACK 10 AWG 79"	62	2263425	SCREW 5/16-20 X 2-1/2" SHCS [2.EA]	123	2263466	SCREW-1/4-20 X 2 STL PPH
12R	640-131	LEADWIRE-RED 10 AWG 80 1/2"	63	2071541	SPRING-SLEEVE UPPER	124	2261233	LEADWIRE VARIABLE
12G	640-305	GROUND WIRE 42"	64	2071535	SPRING SLEEVE, LOWER	124A	2307310	BEAD - FERRITE [2.EA] (CE MODELS ONLY)
	640-306	GROUND WIRE 52"	65	2262712	SPRING, BOWGUARD, FC PAINTED	124B	2075401	HEAT SHRINK 1.1" O.D. X 3.5"
	640-307	GROUND WIRE 62"	67	2262605	PIN- THREADED	125	2020700	TERMINAL RING, 3/8 [2.EA]
13	738-040	BRUSH PLATE 4"	68	2223100	NUT - NYLOC SS [2.EA]	126	2256300	TIE WRAP-5.5 BLACK
14	975-041	SPRING- TORSION [2.EA]	69	2261722	WASHER [2.EA]	127	2263201	CLAMP WIRE HARNESS MICRO [2.EA]
17	701-009	O-RING —THRU BOLT [2.EA]	■	2994832	BAG ASSEMBLY	128	2332103	SCREW-6-20 X 3/8 THD SS
18	701-043	O-RING [2.EA]	*70	2261505	SPACER, MOTOR REST [6.EA]	132	2254031	SWITCH-MOM/OFF/CON
19	830-027	SCREW -SELF THREAD 10-32X2 [2.EA]	*71	2263434	SCREW, 8-18 X 1 PPH SS [2.EA]	133	2266412	SWITCH PLATE, PT PEDAL
20	830-094	THRU BOLT 12-24X10.31 [2.EA]	72	2266000	BEARING BALL-STEEL	134	2332103	SCREW-6-20 X 3/8 THD SS [2.EA]
21	973-025	SPACER- BRUSH PLATE [2.EA]	72A	2266116	BEARING, CARTRIDGE	135	2256301	TIE WRAP-5.5 WHITE [2.EA]
22	990-051	WASHER- STEEL	73	2266001	BEARING, SPLIT RING	136	2264511	BOTTOM PLATE, MAXXUM PT
23	990-052	WASHER- NYLATRON	74	2261622	COLLAR HALF-PAINTED-2 PER- KIT	137	2372100	SCREW-8 X 1/2 SS [5.EA]
24	2316216	MOTOR ASSEMBLY 24V 4" VARS TXT 42"	75	2263453	SCREW-1/4-20 X 3/4 SHCS SS [2.EA]	138	2266610	DECAL-ON/OFF SWITCH
	2316217	MOTOR ASSEMBLY 24V 4" VARS TXT 52"	76	2260283	CONTROL BOX COVER-MAXXUM	139	2262535	CONTROL BOX-PLASTIC
	2316229	MOTOR ASSEMBLY 24V 4" VARS TXT 62"	77	2372100	SCREW-8-18 X 5/8 THD [4.EA]	140	2267800	GEAR-INDICATOR [2.EA]
	2326220	MOTOR ASSEMBLY 24V 4" VARS 42"SONAR	78	2265644	DECAL COVER, MAXXUM 80	141	2262220	INDICATOR-DRIVE
	2326221	MOTOR ASSEMBLY 24V 4" VARS 52" SONAR		2265694	DECAL COVER, MAXXUM 80 US2	142	2261905	BRACKET/INDICATOR
	2326222	MOTOR ASSEMBLY 24V 4" VARS 62" SONAR	79	2260150	POINTER DISC TRNSLCNT RED	143	2301310	SCREW-8-18 X 1/2 SS
25	2032007	TUBE COMP W/4 HOLE 62"	79A	2261733	WASHER-FOAM, INDICATOR	144	2264015	LIGHT/INDICATOR
	2032006	TUBE COMP W/4 HOLE 52"	80	2265800	DECAL-INDICATOR	■	2994830	BAG ASSEMBLY-MAXXUM
	2032005	TUBE COMP W/4 HOLE 48"	81	2053414	SCREW-#8-32 X 1/2 TRI-LOBE [3.EA]	*145	2263431	SCREW 1/4-20 X 3.5 PPH [6.EA]
■	1378132	PROPELLER KIT	82	2267800	GEAR-INDICATOR	*146	2261713	WASHER-1/4 FLAT S/S [6.EA]
26	2331160	PROPELLER W.WEDGE 2	83	2301310	SCREW-8-18 X 1/2 SS	*147	2263103	NUT-1/4-20 NYLOCK-JAM [6.EA]
27	2091701	WASHER-PROP LARGE	84	2355410	SHRINK TUBE-3/8 OD X 2- [3.EA]	148	2265126	BUMPER [4.EA]
28	2093101	NUT-PROP NYLOCK SS	85	2232360	PULLEY-CABLE DRUM	149	2263455	SCREW #12 [4.EA]
29	2262658	PIN-DRIVE SS	86	2261730	WASHER-NYLON	■	2991550	CLAMP COLLAR ASSEMBLY
■	2991842	MOUNT,BOW ASSEMBLY, FW 62 W/O BGRD	87	2996247	PINION/RACE ASSEMBLY	150	2071550	CLAMP COLLAR "A"
	2991841	MOUNT,BOW ASSEMBLY, FW 52 W/O BGRD	88	2223468	SCREW-8-32 X 7/16 ZN PL [4.EA]	151	2071555	CLAMP COLLAR "B"
36	2264246	ARM UPPER-FW LONG	89	2262607	PIN- CLEVIS ZN	152	2072621	PIN-KNURLED
37	2293501	BUSHING, STAINLESS STEEL [4.EA]	90	2260805	SPRING CLIP ZN	153	2070120	KNOB-CLAMP COLLAR
38	2263500	BOLT, SHOULDER MAXXUM [2.EA]	91	2150400	PULL-GRIP	154	2073412	SCREW 1/4-28 X 2 3/4" SS
39	2774317	ARM-LOWER ASSEMBLY,LG,FW,EXT	92	2151700	WASHER-EYE SHAFT .562 OD	155	2071718	WASHER #10 NYLON RETAINING
40	2263913	MOTOR REST LONG MAXXUM	93	2790002	FOOT PEDAL/PLUG ASSEMBLY	156	2071716	WASHER - FLAT SS
41	2265514	DECAL-MAXXUM,MOTOR REST [2.EA]	94	2993702	PUSH BUTTON / MAGNET ASSEMBLY	157	2073102	NUT - HEX 1/4 - 28 SS
42	2773986	BOWPLATE- FW LG MACH/INSERT	95	2302732	SPRING-LOWER PEDAL SS	158	2071560	SPLIT COLLAR
43	2251601	ROPE 40" MAXXUM MOUNT	97	2260810	CLIP, REED SWITCH	159	2211410	EXTENSION CABLE US2
44	2261708	WASHER-3/8X1/2X.010 SS [2.EA]	99	2260160	KNOB-SPEED CONTROL VAR	160	2263804	STRAP - VELCRO 30.5"
45	2267813	BEARING NYLINER- [2.EA]	100	2263000	E-RING TRU-ARC#5133-43	200	2075120	URETHANE PAD
46	2152610	SPRING-PIN LOCKBAR [2.EA]	101	2266413	PLATE -TENSION SCREW FTPED.			
47	2233600	LOCK BAR- BOW MOUNT	102	2260511	PIN-PIVOT A/T PT PDL			
48	2233602	LOCK BAR- REAR ZINC	103	2774550	FT PEDAL BASE/PIN ASSEMBLY			
49	2152700	SPRING-LOCKBAR CAD.PLT	104	2262301	PULLEY- FOOT PEDAL			
50	2262703	SPRING STOP	105	2223430	SCREW #8X3/4 PPH TYPE 25 SS [4.EA]			
51	2153604	EYE SHAFT-2LOCKBAR LG-PLTD	106	2266400	COVER-PULLEY STAMPING			

Seal & O-Ring Kit is p/n 2889460

* This item is part of an assembly. This item cannot be sold separately due to machining and /or assembly that is required. P/N 2274964 REV. N

11-06

Max 80 is 24-volt!

OPTIONAL BROWN WIRE FOR SONAR EQUIPPED MOTORS.
SEE BOAT WIRING DIAGRAM
FIL MARRON OPTIONNEL POUR MOTEURS
ÉQUIPÉS DE SONAR. VOYEZ LE SCHÉMA DE CÂBLAGE DU BATEAU.

