

DeckHand 15 & 25

2-year warranty from date of purchase

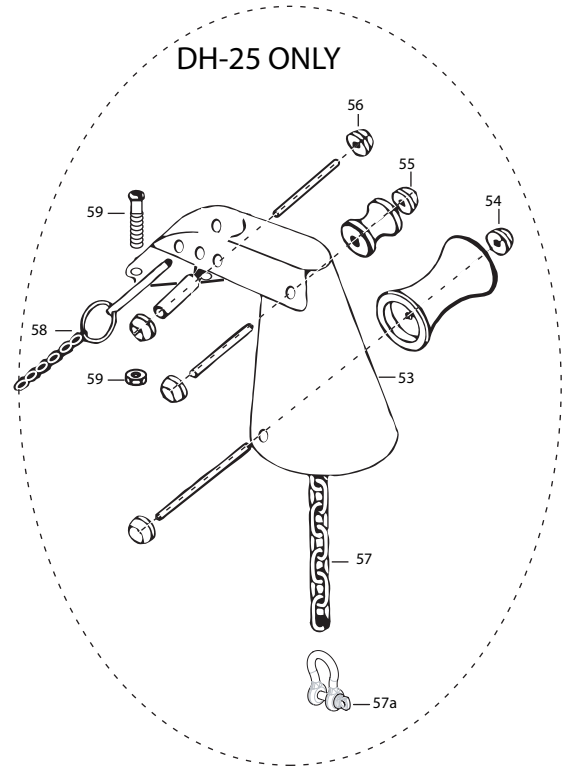

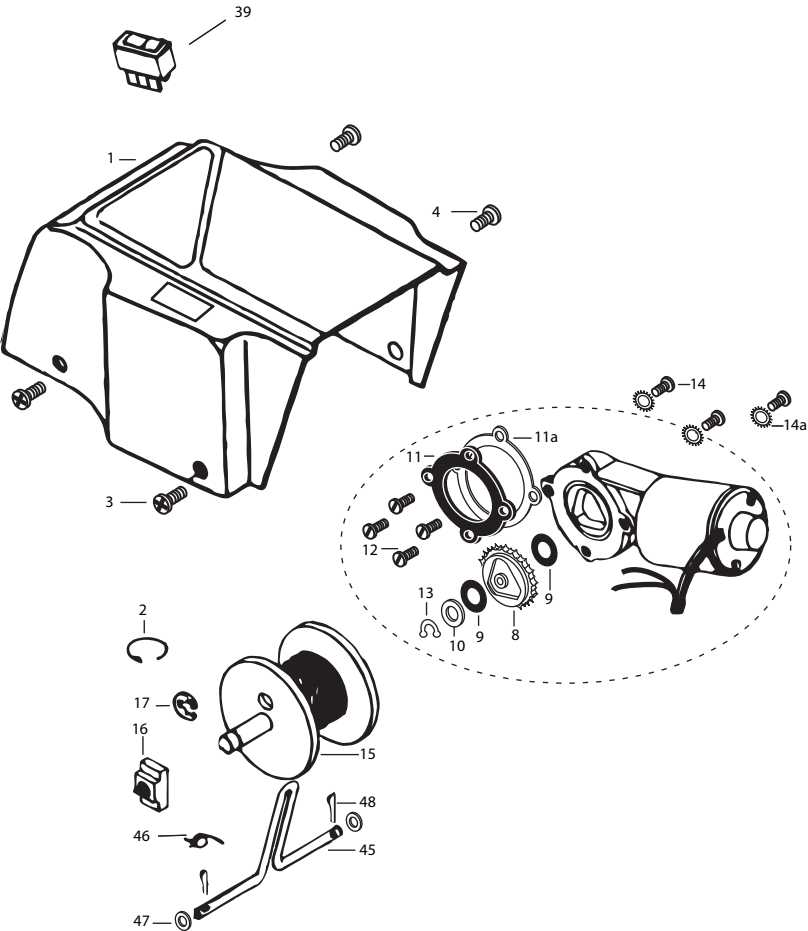
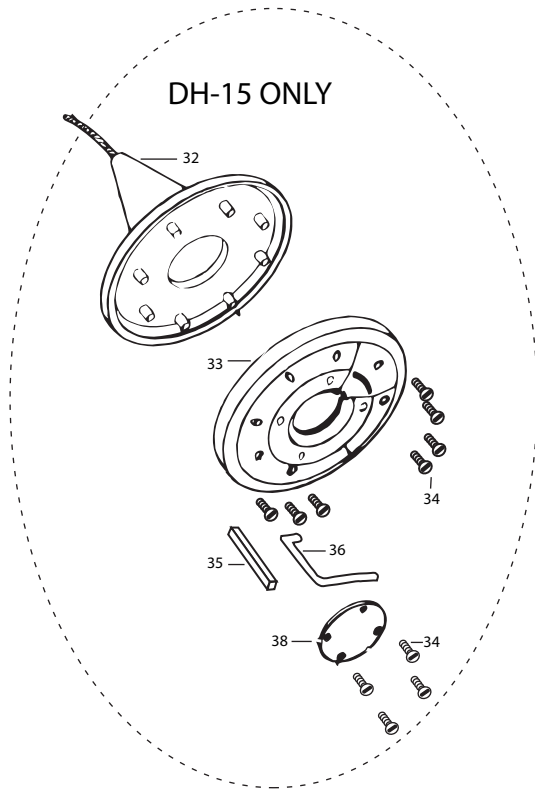
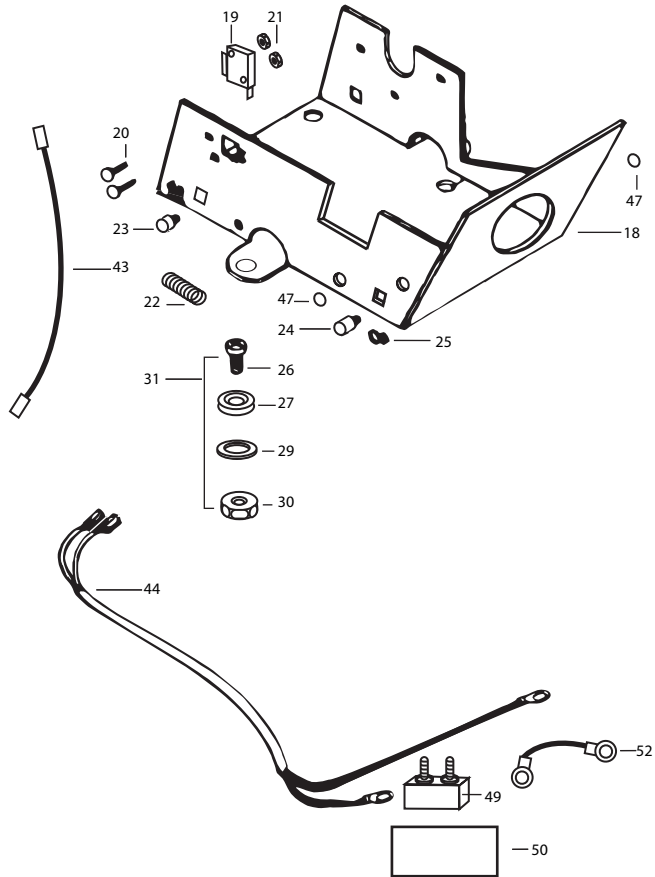

Item	Part	Description
1	2370206	Cover DH-15
		2375506 cover decal
	2370207	Cover DH-25
		2375506 cover decal
3	2372121	Screw-#8-18x 1-1/2 Stallgrd (2 .ea)
4	2372111	Screw-#8-18x 3/4 Stallgrd (2 .ea)
■	2377803	Motor Assembly - DeckHand- Includes 6-13
8	350-154	Gear
9	990-077	Washer - Nylatron (2 .ea)
10	990-075	Washer - Steel
11	410-015	Cover- Housing
11a	337-015	Gasket
12	830-036	Screw - 10-32x.375 (4.ea)
13	788-030	Snap Ring
14	2223455	Screw-#10-32x1/2 (3 .ea)
14a	2261718	Washer- Lock Star #10 Ext Tooth 3.ea)
15	2377900	Spool includes 60' rope
16	2370000	Bearing-Spool
17	2263010	E-Ring 3/8 Dia Shaft
18	2371902	Base- Mounting E-Coat
19	2374010	Switch-Momentary Anchor
20	2372130	Screw-#4-40x3/4 PPH (2 .ea)
21	2373100	Nut-Con/Mom Swt Anchor (2 .ea)
22	2372700	Spring-Anchor
23	2372900	Grommet-Anchor Cover Short (2 .ea)
24	2372910	Grommet-Anchor Cover Long (2 .ea)
25	2376300	Wire- Routing Clip (2 .ea)
■	2994803	Bag Assembly (includes 26-30)
26	2153501	Bolt- Mounting 3500 w/stallgd (4 .ea)
27	2301720	Mounting Washer-Rubber (6 .ea)
29	2151726	Washer 5/16 STD SS (4 .ea)
30	2153100	Nut 5/16 (4 .ea)
31		See 2774805
32	2378000	Anchor-Upper Half (DH-15)
33	2378100	Anchor-Lower Half (DH-15)
34	2372100	Screw #8-18x5/8 (as required)
35	2372800	Keeper Block
36	2373600	Lock Pin-Anchor
38	2376700	Plug-Anchor
39	2374000	Switch-Control Anchor
43	2370707	Jumper Wire
44	2370607	Leadwire
45	2371610	Rope Guide
46	2372710	Spring-Rope Guide
47	2151700	Washer- Eye Shaft (2 .ea)
48	2372615	Cotter Pin 3/32x3/4 (2 .ea)
49	2378204	Circuit Breaker
50	2372031	Tubing- Heat Shrink
52	2371413	Connecting Cable 10ga
53	2998411	Davit Assembly
54	2992312	Large Roller Assembly
55	2992306	Small Roller Assembly
56	2991503	Sleeve Roller Assembly
57	2370820	Safety Chain Assembly
57a	2370806	Anchor Shackles
58	2992620	Safety Pin Assembly
59	2774805	Mounting Bolts and Nuts (4 each)
■	2994804	Bag Assembly -DH 18 (anc. plug + screws)

