

Engine Mount RipTide 101
36 Volt 49 Amps

FOR USE WITH "AH" SERIAL NUMBERS
2-YEAR WARRANTY FROM THE DATE OF PURCHASE

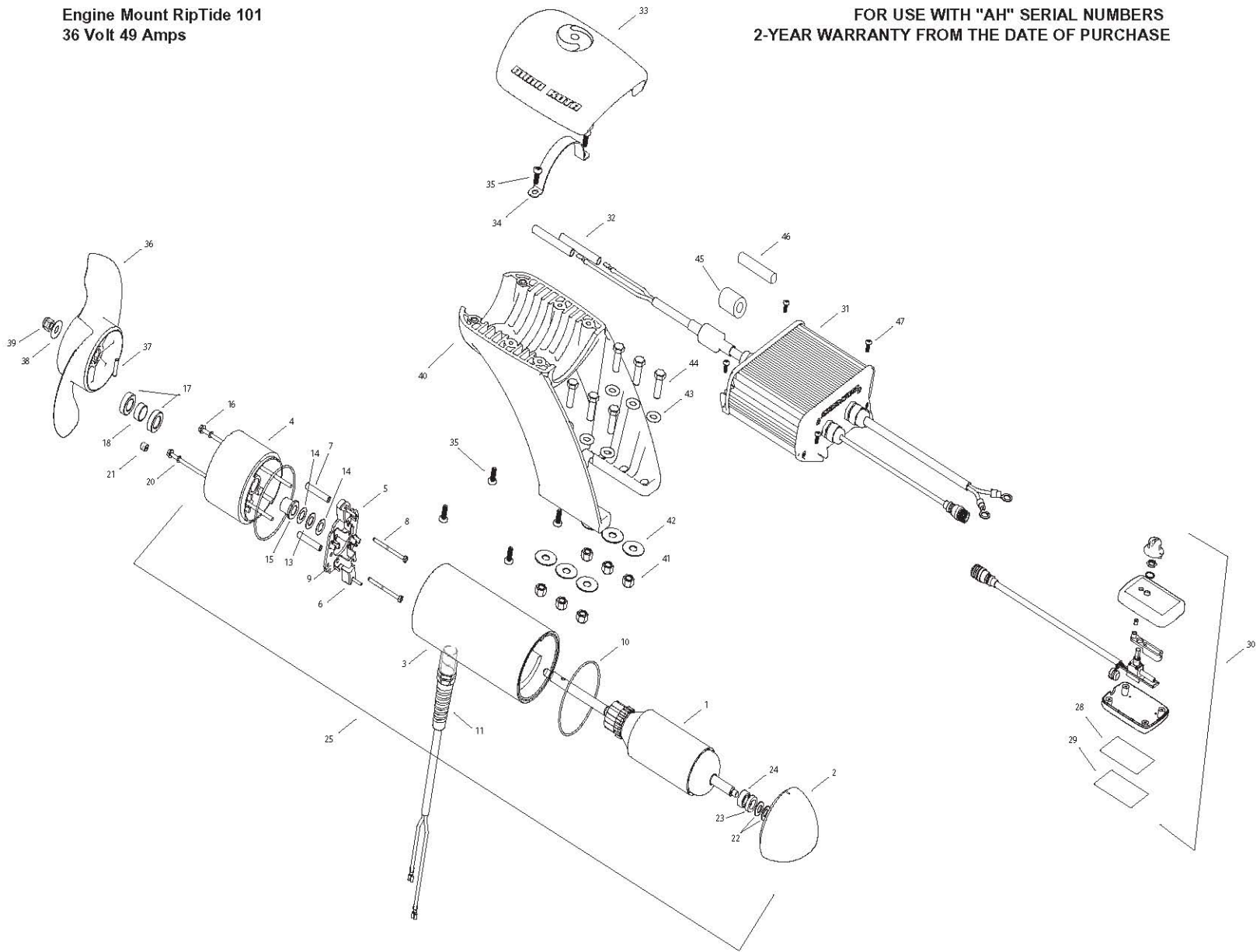

1	2-100-235	ARMATURE 36V 4.0
2	421-376	PLAIN END
3	2-200-309	CENTER HOUSING ASSEMBLY
4	2-300-349	BRUSH END HOUSING (CONTAINS 4-9)
5	2-600-234	BRUSH PLATE ASSEMBLY (CONTAINS 5, 6, 9)
6	188-094	BRUSH
7	973-025	SPACER - BRUSH PLATE
8	830-027	SCREW #10-32 X 2 SLF THREAD
9	975-041	BRUSH SPRING
10	701-043	O-RING [2 EA]
11	2772917	LEADWIRE ASSEMBLY
13	990-051	WASHER STEEL
14	990-052	WASHER NYLATRON
15	144-017	FLANGE BEARING
16	830-096	THRU-BOLT 12-24 X 10.31
17	880-025	SEAL [2 EA]
18	725-095	PAPER TUBE
20	701-009	O-RING THRUBOLT
21	836-001	ALUMINUM PLUG
22	992-010	SPRING WASHER [2 EA]
23	990-045	THRUST SPACER
24	140-010	BALL BEARING
25	2396250	MOTOR ASSY 36V 4.0 101#
28	9950953	VELCRO 1.5 X 2.0 LOOP
29	9950950	VELCRO 1.5 X 2.0 HOOK
30	2990241	HAND CONTROLER
31	2990227	CONTROL MODULE
32	2385401	SHRINK TUBE [2 EA]
33	2380211	TOP CAP
34	2383810	STRAP, EM
35	2383418	SCREW 1/4-20 SELF TAPPING [6 EA]
■	1378132	PROP KIT
36	2331160	PROPELLER
37	2262658	DRIVE PIN
38	2091701	WASHER, PROP LARGE
39	2198401	NUT, PROP
40	2381940	LOWER BRACKET
41	2383122	NUT 3/8-16 NYLOCK [6EA]
42	2381726	WASHER FENDER 3/8 X 1 1/4 OD [3 EA]
43	2381728	WASHER 3/8 [3 EA]
44	2383422	SCREW 3/8 X 1 1/4 [6EA]
45	2307310	FERRITE BEAD (EUROPEAN MOTORS ONLY)
46	2075401	HEATSHRINK (EUROPEAN MOTORS ONLY)
47	2373427	SCREW #12 X 5/8 [4 EA]
■	2994856	BAG ASSY (CONTAINS 38-41,32,28,29,47, TIE WRAPS)

36V

