

RT55/t
55 LBS. THRUST
12 VOLT 50 AMPS
36" OR 42" SHAFT

for use with "AH" serial numbers
3-year warranty from the date of purchase

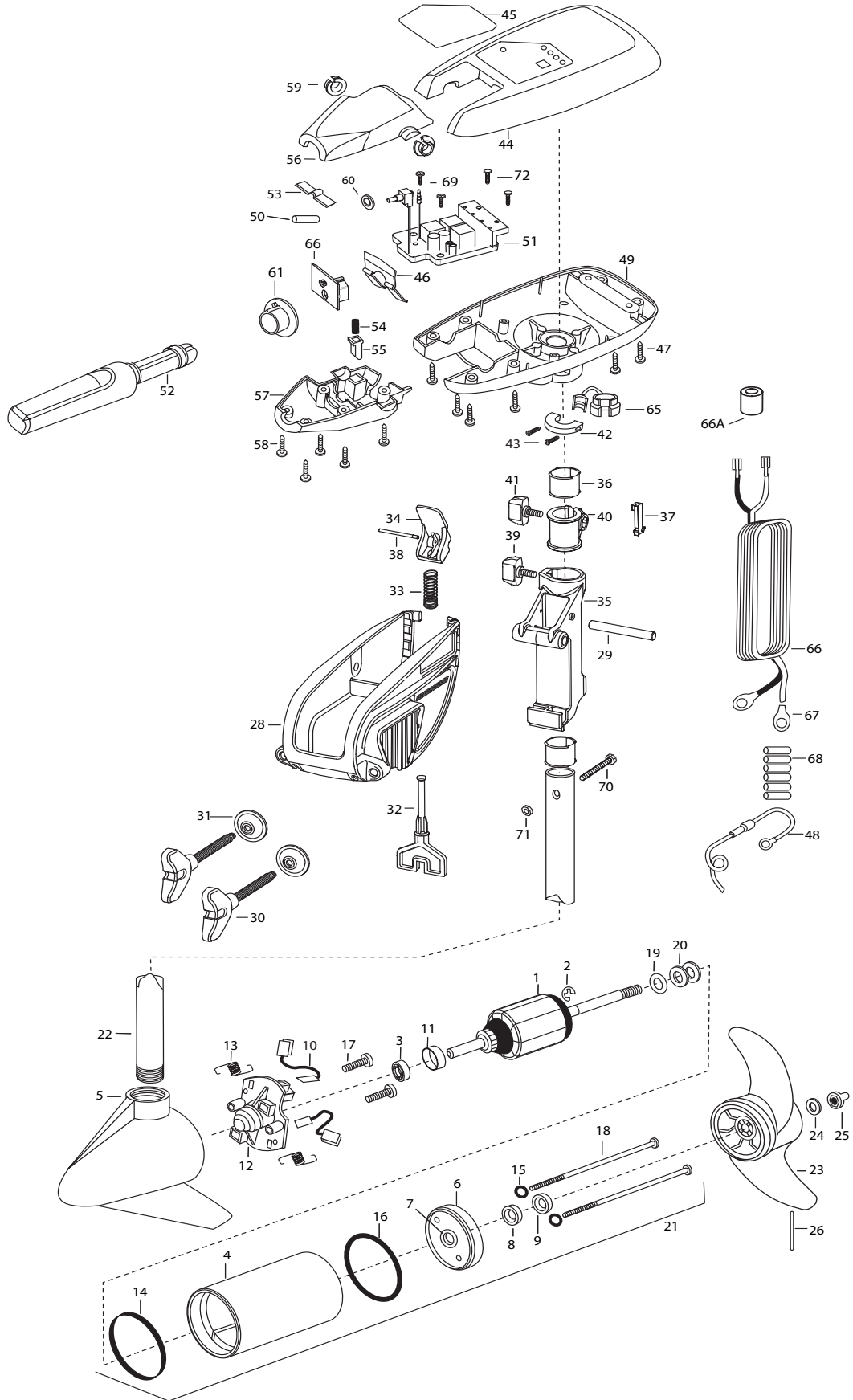

1	2-100-115	ARMATURE ASSEMBLY12V 3.625 55#	36	2037301	BUSHING-HINGE [2.EA]
2	788-015	RETAINING RING	37	2062800	TENSION BLOCK- SNAP IN" [2.EA]
3	140-010	BEARING -BALL	38	2060516	PIN-TILT LEVER ENDURA
4	2-200-301	CENTER HOUSING ASSEMBLY 3.62 SW WHT	39	2011386	SCREW-TENSION/NEW KNOB
5	421-336	HOUSING BRUSH END 3.625 SW WH	40	2061520	COLLAR-DEPTH
6	2-400-337	PLAIN END HOUSING 3.625 S/W	41	2011366	SCREW-COLLAR/NEW KNOB SS [2.EA]
7	144-049	BEARING - FLANGE (SERVICE ONLY)	42	2061517	COLLAR-CTRL BOX WHITE
8	880-003	SEAL	43	2263434	SCREW-#8X1" PPH TYPE 25 SS [2.EA]
9	880-006	SEAL WITH SHIELD	44	2300219	COVER-CONTROL BOX RIPTIDE WHITE
10	188-036	BRUSH ASSEMBLY [2. EA]	45	2095681	DECAL-COVER RT55/S/B WHT
11	725-050	BRUSH RETENTION	46	2302743	SPRING-DETENT HANDLE-TILT
12	738-036	BRUSH PLATE W/HOLDER	47	2303412	SCREW- 6-20X5/8 SELF TAP [6.EA]
13	975-040	SPRING - TORSION [2.EA]	48	2060310	CONNECT'GROUND WIRE-FUSED
14	337-036	GASKET	49	2062596	CONTROL BOX,SW, WHT .725 BORE
15	701-008	O-RING [2. EA]	50	2305410	SHRINK TUBING
16	701-081	O-RING	51	2184000	CONTROL BOARD ASSEMBLY 12V
17	830-007	SCREW #8-32 [2.EA]	52	2990915	HANDLE ASSEMBLY W/O U-JOINT
18	830-042	THRU BOLT 10-32X8.83 [2. EA]	53	2302742	SPRING-DETENT (OFF) SS
19	990-067	WASHER - STEEL THRUST	54	2302745	SPRING-RELEASE BUTTON SS
20	990-070	WASHER - NYLATRON [2.EA]	55	2303720	RELEASE BUTTON-HANDLE
21	2097096	MOTOR ASSEMBLY 12V 3.625 VARS SW	56	2060411	HANDLE- TOP HALF MAXIMIZE
22	2032031	TUBE (COMPOSITE) 36"	57	2060415	HANDLE- LOWER HALF
	2032032	TUBE (COMPOSITE) 42"	58	2303412	SCREW- 6-20X5/8 SELF TAP [5.EA]
■	1378131	PROPELLER KIT	59	2060005	BEARING-HANDLE PIVOT [2.EA]
23	2091160	PROPELLER W/WEDGE 2	60	2181700	WASHER SPACER
24	2151726	WASHER- 5/16 STD SS	61	2992852	ACTUATOR-CAM
25	2198400	ANODE-ZINC 3.25/3.625 LWR U	62	2184020	POT ADAPTER
26	2092600	PIN-DRIVE	65	2052900	STRAIN RELIEF-C.CORD/SP.C
■	2771816	BRACKET & HINGE ASSEMBLY ENDURA SW	66	2090600	LEADWIRE (10 GA) RINGS
■	2771913	BRACKET ASSY INC. 28, 30, & 31	66A	2307310	BEAD - FERRITE (CE MODELS ONLY)
28	2061910	BRACKET	67	2020700	TERMINAL RING, 3/8" [2.EA]
29	2060511	PIN-HINGE ENDURA SS	68	2305401	SHRINK TUBE- .374 X 1.50 [4 EA.]
30	2061301	SCREW-CLAMP ENDURA [2.EA]	69	2372100	SCREW- 8-18X5/8 THD SS [2.EA]
31	2331700	WASHER-CLAMP SCREW 1.5 OD [2.EA]	70	2263406	SCREW- 10-24X2 SS
32	2063605	T-BAR PLASTIC ENDURA	71	2333101	NUT-10-24 NYLOCK UNC-2B
33	2062706	SPRING- T-BAR ENDURA	72	2301310	SCREW- 8-18X1/2 SS [2.EA]
34	2067201	LEVER- TILT ENDURA BLACK			
35	2061810	HINGE- PLASTIC ENDURA			

RT55t is 12-volt!

