

**MAXXUM 33T**  
**33 LBS. THRUST**  
**12 VOLT 32 AMPS**  
**30" SHAFT**

**for use with "AH" serial numbers**  
**3-year warranty from the date of purchase**

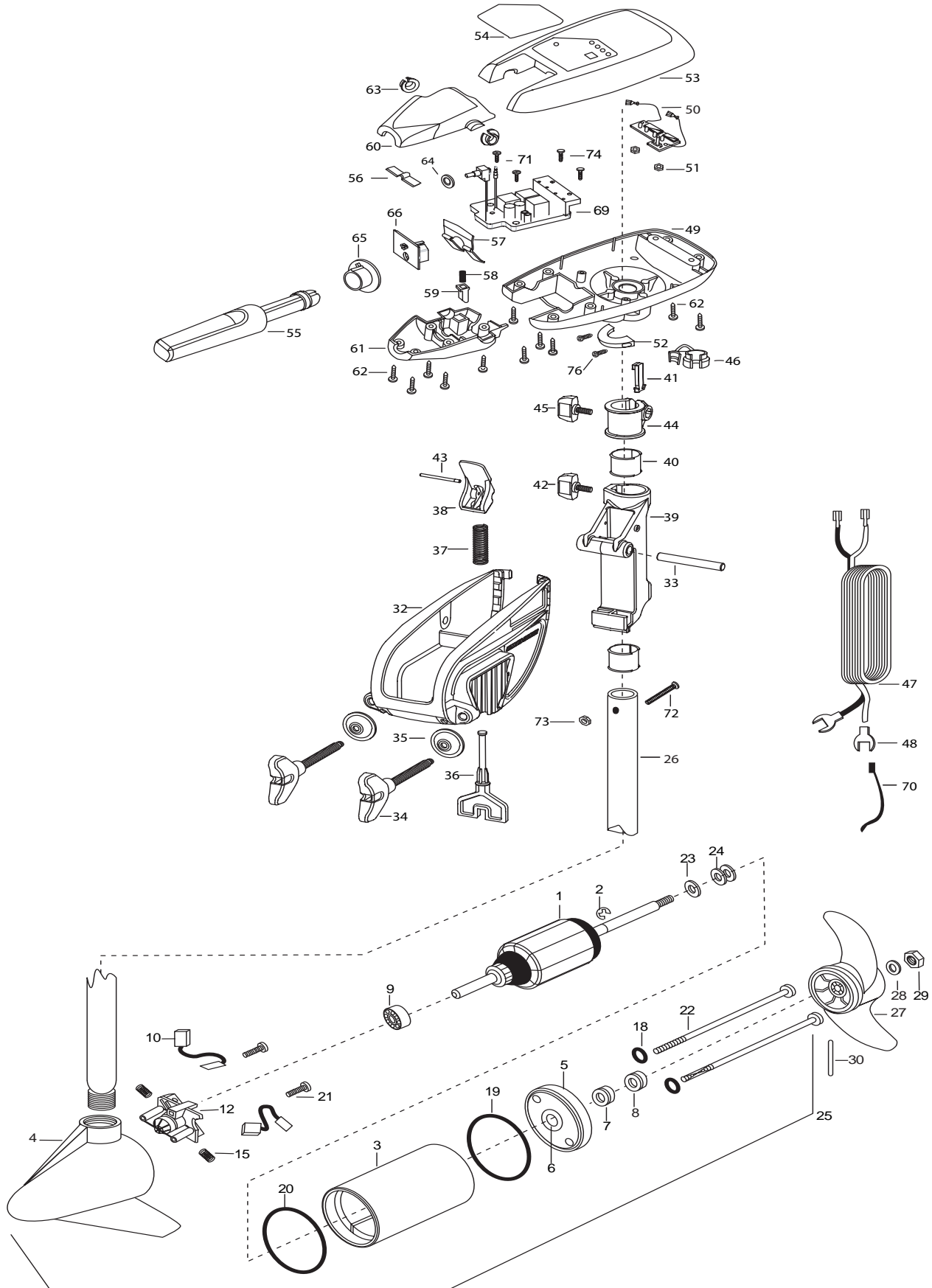

1	2-100-278 ARMATURE ASSEMBLY 12V 3.25	■	2771910	BRACKET ASSEMBLY	56	2302742	SPRING DETENT(OFF)
2	788-015 RETAINING RING			(INCLUDES- 32,33,34)	57	2302743	SPRING DETENT(HANDLE TILT)
3	2-200-079 HOUSING- CENTER ASSEMBLY 3.25 FW	*32	2061910	BRACKET-PLASTIC	58	2302745	SPRING RELEASE BUTTON
4	421-132 HOUSING- BRUSH END 3.25 TXT	33	2060510	PIN-HINGE	59	2303720	RELEASE BUTTON HANDLE
5	2-400-128 HOUSING- PLAIN END ASSEMBLY 3.25	■	2881300	CLAMP SCREW, WASHER, RETAINER	60	2060409	HANDLE (TOP HALF) MAXIMIZE
6	144-049 BEARING - FLANGE			KIT INCLUDES 2.EA	61	2060415	HANDLE (LOWER HALF)
7	880-003 SEAL	*34	2061300	SCREW-CLAMP [2.EA ]	62	2303412	SCREW 6-20 X 5/8 SELF TAP [11.EA ]
8	880-006 SEAL WITH SHIELD	*35	2011710	WASHER-CLAMP SCREW 1.5OD [2.EA ]	63	2060005	BEARING HANDLE PIVOT [2.EA ]
9	140-010 BEARING - BALL	36	2063605	T BAR, PLASTIC	64	2181700	WASHER SPACER
10	188-052 BRUSH ASSEMBLY [2 REQ'D]	37	2062706	SPRING (T BAR)	65	2992852	ACTUATOR CAM
12	738-030 BRUSH PLATE W/HOLDER 3.25 ASSEMBLY	38	2067201	LEVER TILT BLACK	66	2184020	POT ADAPTER
15	975-032 SPRING - COMPRESSION	39	2061810	HINGE PLASTIC	69	2184000	CONTROL BOARD ASSEMBLY 12V
18	701-007 O-RING [2. EA]	40	2037300	BUSHING HINGE [2.EA ]	70	2256300	TIE WRAP 5.5" BLACK
19	701-039 O-RING MK406460	41	2062800	TENSION BLOCK "SNAP IN	71	2372100	SCREW 8-18 X 5/8 THD* SS [2.EA ]
20	701-041 O-RING	42	2011385	SCREW TENSION/NEW KNOB	72	2383407	SCREW 10-24 X 2 PPH ZINC
21	830-001 SCREW - #8-32X1.75 SELF THRD [2.EA ]	43	2060515	PIN, TILT LEVER	73	2383124	NUT 10-24 NYLOCK ZINC
22	830-078 THRU BOLT 8-32 X 8.96 [2. EA]	44	2061520	COLLAR DEPTH	74	2301310	SCREW 8-18 X 1/2 (SS) 2. EA
23	990-067 WASHER - STEEL THRUST	45	2011365	SCREW COLLAR/NEW KNOB	76	2263434	SCREW #8 X 1" PPH SS [2.EA]
24	990-070 WASHER - NYLATRON [2. EA]	46	2052900	STRAIN RELIEF C.CORD/SP.C			
25	2069245 MTR ASSEMBLY 12V 3.25 VARS TXT 47	47	2050609	LEADWIRE-10 GA SPADE TERM			
26	2032051 TUBE (COMPOSITE) 30	48	2020702	TERMINAL- SPADE 10GA 2.EA			
■	1378126 PROP KIT	49	2062592	CONTROL BOX,FW,.725 BORE,ZIN			
27	2061125 PROPELLER W/WEDGE	50	2074070	BATTERY GAUGE 12 VOLTS			
28	2151726 WASHER- 5/16 STD SS	51	2303120	SPEED NUT [2.EA ]			
29	2053101 NUT-PROP NYLOC 5/16	52	2061515	COLLAR CTRL BOX (FRS WTR)			
30	2092600 PIN-DRIVE (95-4HP'S) (SS)	53	2990294	CTRL BOX CVR/DECAL ASSEMBLY			
■	2771818 BRACKET & HINGE ASSEMBLY-	54	2065626	DECAL COVER (MAX 33T TRANS)			
	(INCLUDES- 32- 43)	55	2990976	HANDLE ASSEMBLY W/O U-JOINT			

# Max33T is 12-volt!

