

Riptide 80 SM (hinged door)
80 LBS THRUST
24 VOLT 56 AMP
52" SHAFT

for use with "AI" serial numbers
3-year warranty from the date of purchase

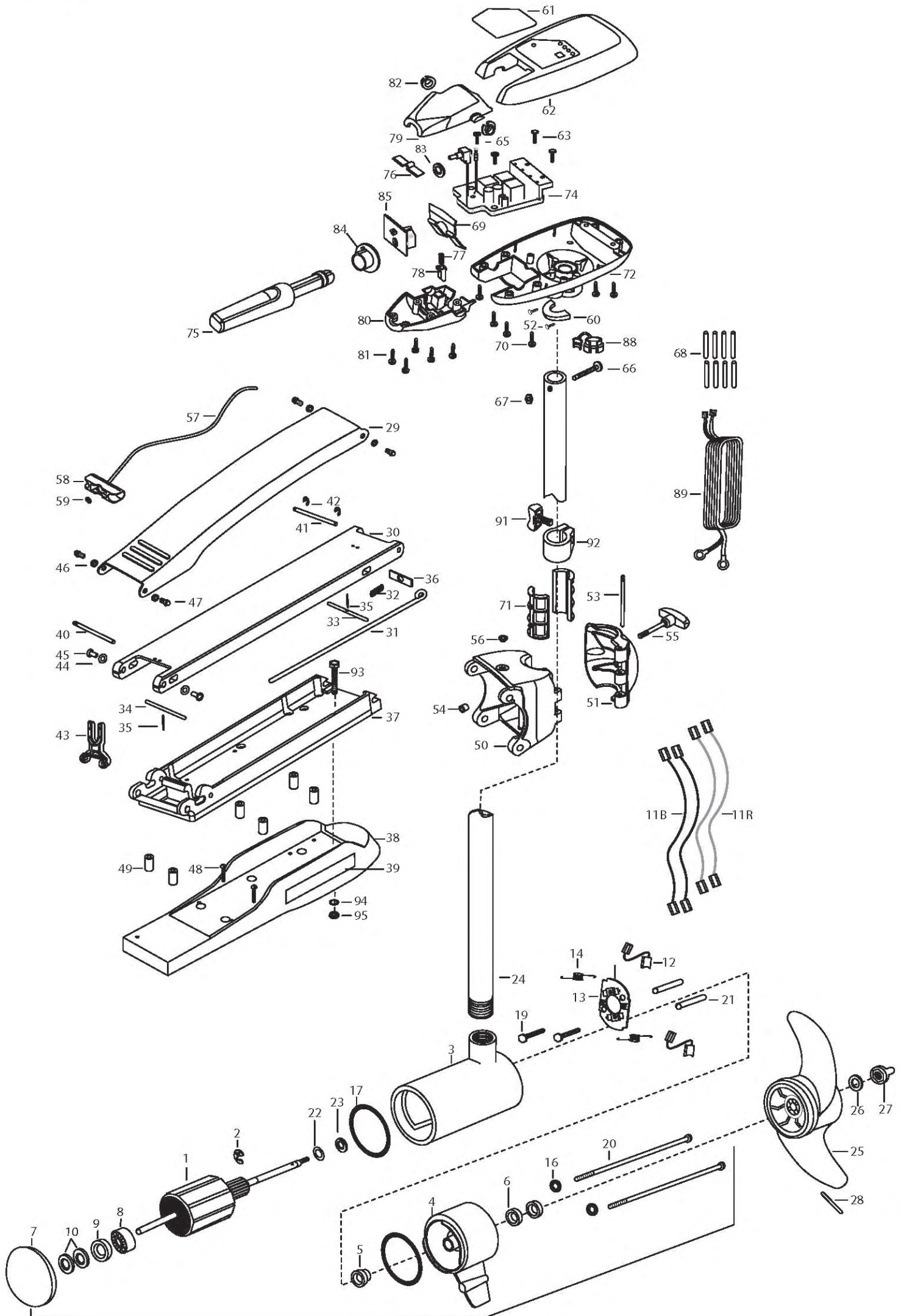

1	2-100-214	ARMATURE ASSEMBLY 24V 4	33	2233601	LOCKBAR (SS) (NEW 500)	68	2305401	SHRINK TUBE-.374 X 1.50 [4 EA.]
2	788-040	RETAINING RING	34	2233603	LOCK BAR, REAR S/S	69	2302743	SPRING-DETENT -HANDLE-TILT
3	2-200-397	HOUSING ASSEMBLY CENTER	35	2152610	SPRING-PIN (LOCKBAR) [2.EA]	70	2303412	SCREW-6-20 X 5/8 SELF TAP [6.EA]
4	2-300-340	BRUSH END HOUSING ASSEMBLY	36	2262703	SPRING STOP	71	2151532	HINGE-SLEEVE HALF-AT [2.EA]
5	144-017	BEARING- FLANGE	37	2993983	BOWPLATE/INSRT ASSEMBLY,STD,SW	72	2062596	CONTROL BOX- SW WHT
6	880-025	SEAL [2.EA]	38	2263914	MOTOR REST STD MAXXUM WHT	74	2184005	CONTROL BOARD ASSEMBLY 24/36V
7	421-376	PLAIN END HOUSING ASSEMBLY	39	2065676	DECAL- MOTOR REST RT W [2.EA]	75	2990915	HANDLE ASSEMBLY W/O U-JOINT
8	140-010	BALL BEARING	40	2260505	PIN-HINGE (HEADLESS) S/S	76	2302742	SPRING-DETENT(OFF) SS
9	992-010	THRUST SPACER	41	2260512	HINGE PIN (MAX,A/T) S/S	77	2302745	SPRING-RELEASE BUTTON SS
10	990-045	SPRING WASHER [2.EA]	42	2263011	E-RING 3/8 DIA. SHAFT [2.EA]	78	2303720	RELEASE BUTTON-HANDLE
11B	640-018	BRUSH LEAD- BLACK WIRES [2.EA]	43	2293811	YOKE,MAX MNT-POLYPROPYLENE	79	2060411	HANDLE (TOP HALF)
11R	640-123	BRUSH LEAD- RED WIRES [2.EA]	44	2261708	WASHER-3/8X1/2X.010 (SS) [2.EA]	80	2060415	HANDLE (LOWER HALF)
12	188-094	BRUSH [2.EA]	45	2267318	BEARING NYLINER [2.EA]	81	2303412	SCREW-6-20 X 5/8 SELF TAP [5.EA]
13	738-004	BRUSH PLATE- 4" TERMINAL	46	2293501	BUSHING, STAINLESS STEEL [4.EA]	82	2060005	BEARING-HANDLE PIVOT [2.EA]
14	975-041	SPRING- TORSION [2.EA]	47	2263500	BOLT, SHOULDER [4.EA]	83	2181700	WASHER SPACER
16	701-009	O-RING- THRU BOLT [2.EA]	48	2263434	SCREW, 8-18 X 1' PPH SS [2.EA]	84	2992852	ACTUATOR-CAM
17	701-043	O-RING [2.EA]	49	2261505	SPACER, MOTOR REST [6.EA]	85	2184020	POT ADAPTER
19	830-027	SCREW- SELF-THREAD I0-32X2 [2.EA]	50	2991863	HINGE BASE/INSERT ASSEMBLY,SW,	88	2052900	STRAIN RELIEF-C.CORD/SP.C
20	830-094	THRU BOLT 12-24 x I0.31 [2.EA]	51	2261859	HINGE DOOR- SW TEX WHT	89	2090650	LEADWIRE (10 GA) (RINGS)
21	973-025	SPACER - BRUSHPLATE [2.EA]	52	2263434	SCREW- #8X1" PPH TYPE 25 SS [2.EA]	91	2011366	SCREW-COLLAR/NEW KNOB (SS)
22	990-051	WASHER- STEEL THRUST	53	2262642	PIN-HINGE DOOR, RT HNG/DOOR	92	2031520	COLLAR-DEPTH (W/O INSERT)
23	990-052	WASHER- NYLATRON	54	2264706	INSERT-HINGE BASE (STD MT)	■	2994830	BAG ASSEMBLY
■	2316228	MOTOR ASSEMBLY 24V 4 VARS SW 74/ INCL.1-23	55	2260902	KNOB-HINGE COVER SW S/S	93	2263431	SCREW 1/4-20 X 3.5 PPH [6.EA]
24	2032034	TUBE-CARBON COMPOSITE 52 WHT	56	2232315	EYELET-ROPE STAINLESS STEEL	94	2261713	WASHER-1/4 FLAT S/S [6.EA]
■	1378132	PROPELLER KIT	57	2251601	ROPE (40"),	95	2263103	NUT-1/4-20 NYLOCK-JAM S/S [6.EA]
25	2331160	PROPELLER (W.WEDGE 2)	58	2150400	PULL-GRIP			
26	2091701	WASHER-PROP (LARGE)	59	2151700	WASHER-EYE SHAFT(.562 OD)			
27	2198401	ANODE-ZINC 4.0 LWR UNIT	60	2061517	COLLAR-CTRL BOX WHT			
28	2262658	PIN-DRIVE	61	2095684	DECAL-COVER, RT80/B/S HC			
■	2991886	MOUNT,BOW ASSEMBLY,SW STD HNGD	62	2300219	COVER- CONTROL BOX RIPTIDE WHITE			
29	2264244	ARM-UPPER STD SW TEXTURED WHT	63	2043427	SCREW-8-18 X 7/8 SS [2.EA]			
30	2994310	ARM-LOWER ASSEMBLY ,STD SW WHT	65	2043427	SCREW-8-18 X 7/8 SS [2.EA]			2889460 seal & oring kit
31	2153603	EYE SHAFT-2 LOCKBAR STD SS	66	2263406	SCREW-#10-24 X 2" SS PPH			
32	2152701	SPRING-(LOCKBAR) SS	67	2333101	NUT-HEX 10-24 UNC-2B NYLOC			

* This item is part of an assembly. This item cannot be sold separately due to machining and /or assembly that is required.

p/n 2194934 REV. L 3-08

RipTide 80 SM is 24-volts only!

wiring diagram for control board #2184003:

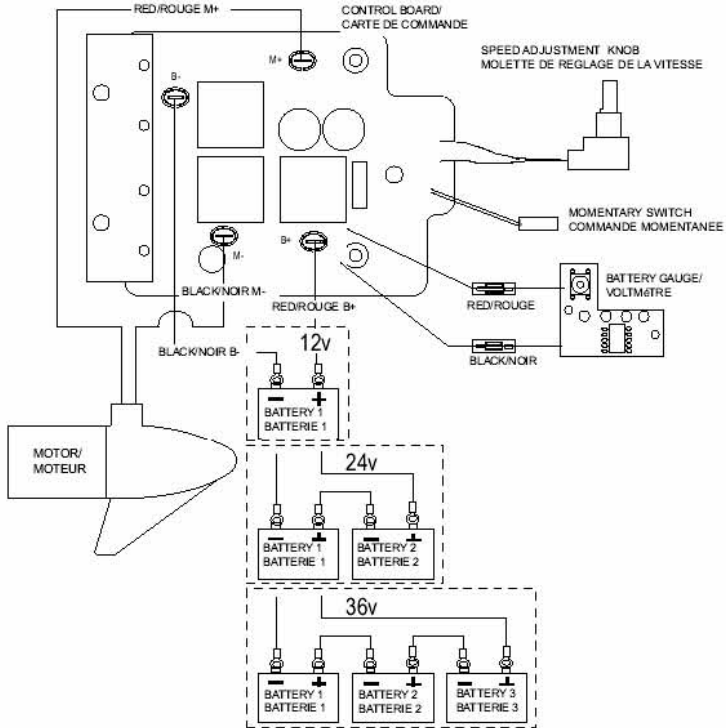

wiring diagram for control board #2184005:

