

**MAXXUM 40T**  
**40 LBS. THRUST**  
**12 volt 42 amp**  
**36" OR 42" SHAFT**

**for use with "AI" serial numbers**  
**3-year warranty from the date of purchase**

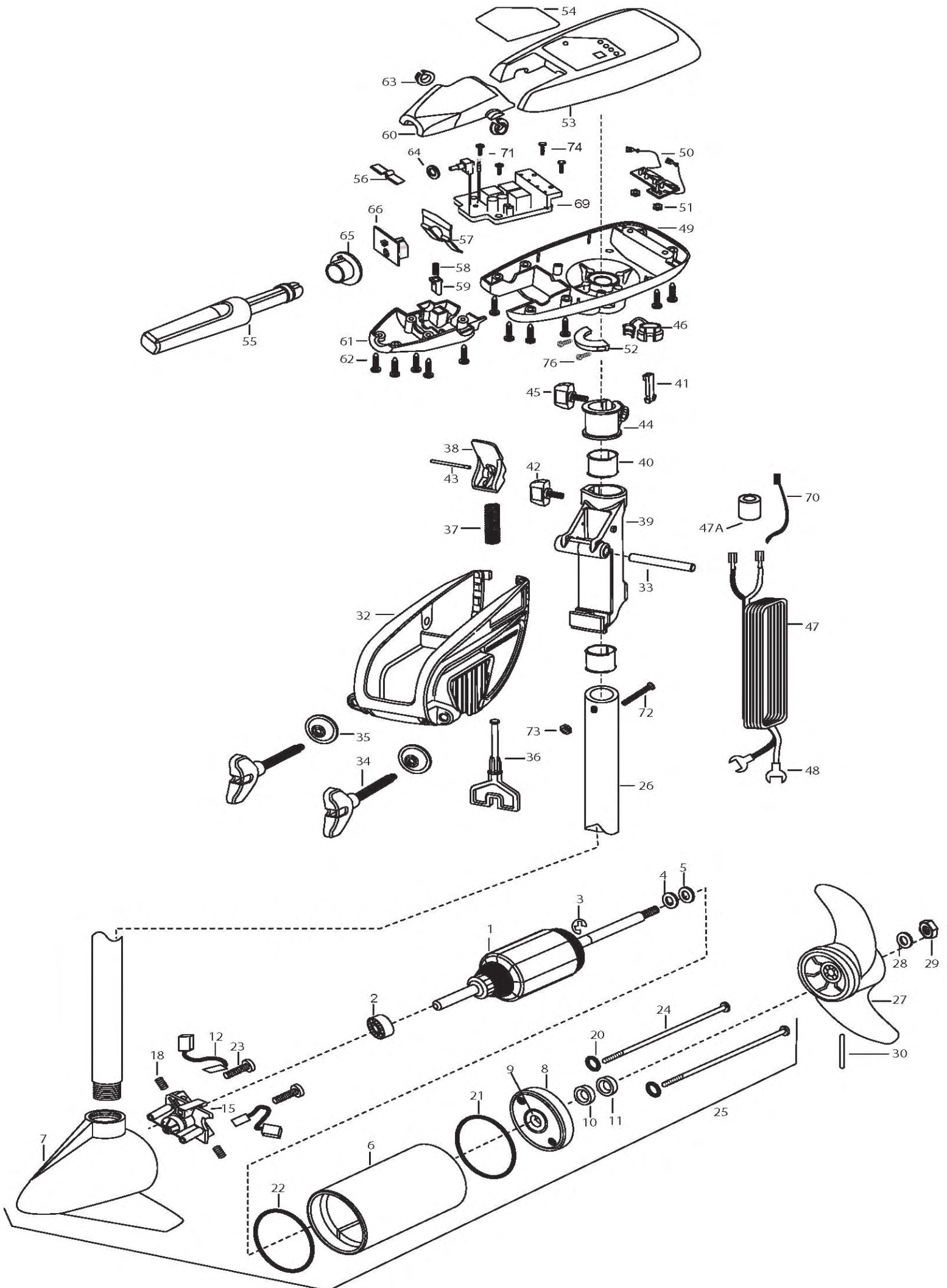

1	2-100-201	ARM ASSEMBLY 12V 3.25 40#	44	2061520	COLLAR DEPTH
2	140-010	BEARING-BALL	45	2011365	SCREW COLLAR/NEW KNOB
3	788-015	RETAINING RING	46	2052900	STRAIN RELIEF C.CORD/SP.C
4	990-067	WASHER- STEEL THRUST	47	2050609	LEADWIRE-10 GA SPADE TERM
5	990-070	WASHER- NYLATRON [2.EA]	47A	2307310	BEAD - FERRITE (CE MODELS ONLY)
6	2-200-079	HOUSING ASSEMBLY CENTER 3.25 TXT	48	2020702	SPADE TERMINAL 10GA. [2.EA]
7	421-132	HOUSING BRUSH END 3.25 TXT	49	2062592	CONTROL BOX FW .725 BORE ZIN
8	2-400-187	PLAIN END HOUSING ASSEMBLY 3.25	50	2074070	BATTERY GAUGE 12 VOLTS
9	144-049	BEARING- FLANGE	51	2303120	SPEED NUT [2.EA ]
10	880-003	SEAL	52	2061515	COLLAR CTRL BOX FRS WTR
11	880-006	SEAL WITH SHIELD	53	2260290	CONTROL BOX COVER BLK W/PRINT
12	188-052	BRUSH ASSEMBLY [2 REQ'D]	54	2065621	DECAL- COVER MAX 40T TRANS
15	738-030	BRUSH PLATE W/HOLDER 3.25 ASSEMBLY	55	2990914	HANDLE ASSEMBLY W/O U-JOINT
18	975-032	SPRING- COMPRESSION [2.EA]	56	2302742	SPRING DETENT (OFF)
20	701-007	O-RING [2. EA]	57	2302743	SPRING DETENT HANDLE TILT
21	701-039	O-RING MK406460	58	2302745	SPRING RELEASE BUTTON
22	701-041	O-RING	59	2303720	RELEASE BUTTON HANDLE
23	830-001	SCREW - SELF-THREAD 8-32X1.7 [2.EA ]	60	2060409	HANDLE- TOP HALF MAXIMIZE
24	830-078	THRU BOLT 8-32X8.96 [2. EA]	61	2060415	HANDLE- LOWER HALF
25	2068251	MTR ASSEMBLY 12V 3.25 VARS TXT	62	2303412	SCREW- 6-20X5/8 SELF TAP [11.EA ]
26	2032052	TUBE (COMPOSITE) 36	63	2060005	BEARING HANDLE PIVOT [2.EA ]
	2032053	TUBE (COMPOSITE) 42	64	2181700	WASHER SPACER
■	1378126	PROPELLER KIT	65	2992852	ACTUATOR CAM
27	2061125	PROPELLER W/WEDGE	66	2184020	POT ADAPTER
28	2151726	WASHER-5/16 STD SS	69	2184004	CONTROL BOARD ASSEMBLY 12V
29	2053101	NUT-PROP NYLOC	70	2256300	TIE WRAP 5.5" BLACK
30	2092600	PIN-DRIVE (SS)	71	2043427	SCREW- #8-18X7/8 THD SS [2.EA ]
■	2771818	BRACKET & HINGE ASSEMBLY- INCLUDES 32- 43	72	2383407	SCREW- #10-24X2 PPH ZINC
■	2771910	BRACKET ASSEMBLY- INCLUDES 32,33,34	73	2383124	NUT- 10-24 NYLOCK ZINC
*32	2061910	BRACKET-PLASTIC	74	2043427	SCREW- #8 18 X 7/8 SS [2. EA]
33	2060510	PIN-HINGE	76	2263434	SCREW #8X1" PPH TYPE 25 SS [2.EA]
■	2881300	SCREW CLAMP, WASHER, RETAINER KIT [2.EA]			
*34	2061300	SCREW CLAMP [2.EA ]	2355410		SHRINK TUBE
*35	2011710	WASHER- CLAMP SCREW 1.5 OD [2.EA ]			
36	2063605	T BAR- PLASTIC			
37	2062706	SPRING- T BAR			
38	2067201	LEVER TILT BLACK			
39	2061810	HINGE PLASTIC			
40	2037301	BUSHING HINGE [2.EA ]			2883460 seal & oring kit
41	2062800	TENSION BLOCK "SNAP IN			
42	2011385	SCREW TENSION/NEW KNOB			
43	2060515	PIN, TILT LEVER			

\* This item is part of an assembly. This item cannot be sold separately due to machining and /or assembly that is required.

P/N 2034960 REV. J ECN 30910 6-08

# Maxxum 40T is 12-volt only!

wiring diagram for control board #2184002:

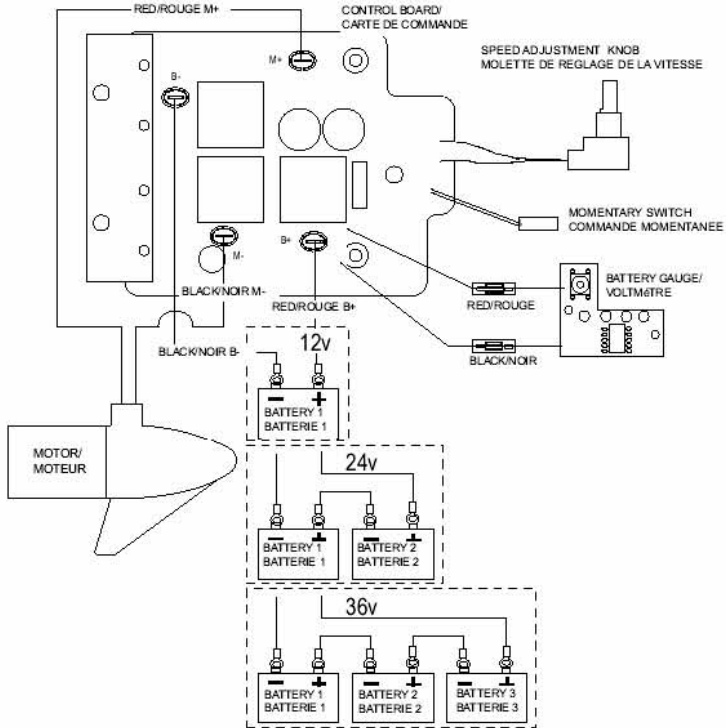

wiring diagram for control board #2184004:

