

# MAXXUM 101

101 lbs Thrust

36 Volt 46 Amps

42" SHAFT

for use with "J" serial numbers

3-year warranty from the date of sale

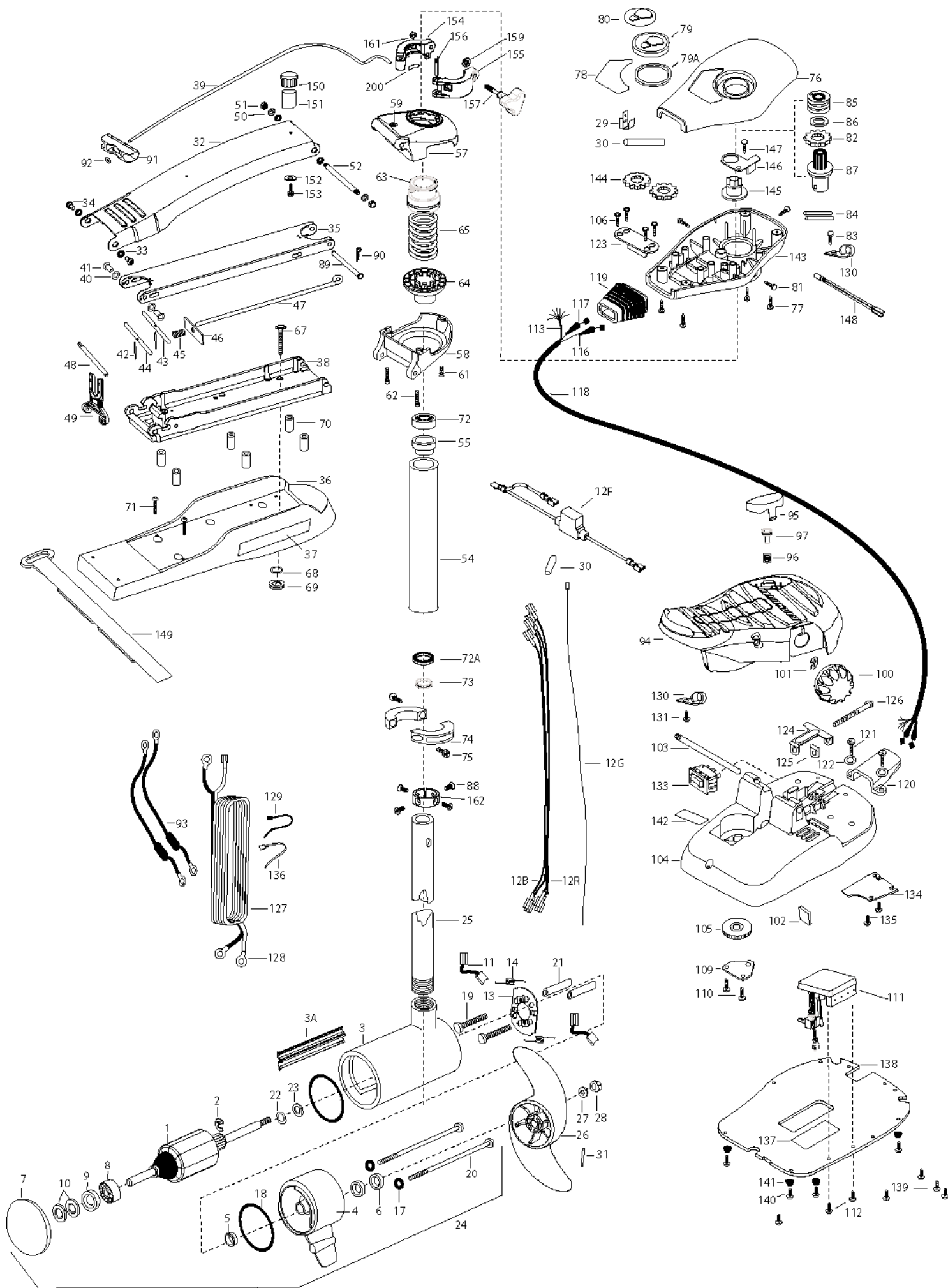

1	2-100-216	ARMATURE ASSEMBLY 36V 4 VARS TXT	51	2223100	NUT- TENSION 5/16-18 SS [2.EA]	109	2266401	COVER-PULLEY STAMPING
2	788-040	RETAINING RING	52	2262605	PIN- BWGRD UPPER THREADED ZP	110	2301310	SCREW-8-18 X 1/2" SS [2.EA]
3	2-200-110	CENTER HOUSING ASSEMBLY 4.0 FW TXT 101	■	2772085	TUBE W/BEARING RACE ASSEMBLY	111	2264054	CONTROL BOARD ASSY 24-36V MAX
3A	582-014	CLIP, RETAINING, US2	54	2272085	TUBE OUTER -21" 4 HOLES	112	2263455	SCREW 10-32 X 1/2 [2.EA]
4	2-300-160	BRUSH END HOUSING ASSEMBLY 4.0 FW TXT	55	2266260	BEARING RACE- 565T	113	2261220	WIRE HARNESS MAX 101
5	144-017	BEARING -FLANGE (SERVICE ONLY)				116	2267505	CABLE ASSEMBLY-RIGHT 5'
6	880-025	SEAL [2.EA]	■	2991763	BOWGUARD ASSEMBLY-FT CT FW	117	2267515	CABLE ASSEMBLY-LEFT 5'
7	421-276	PLAIN END HOUSING ASSEMBLY 4.0	57	2772319	BRACKET BASE TOPEYELET	118	2265430	CABLE JACKET 5'
	9421-284	PLAIN END HOUSING ASSEMBLY 4.0 US2 42"	58	2991770	BRACKET BOTTOM/BEARING ASSEMBLY	119	2265110	BOOT-CONTROL BOX
8	140-010	BALL BEARING	59	2772352	EYELET KIT -ROPE	120	2265115	BOOT-FOOT PEDAL BASE
9	990-045	THRUST SPACER	61	2263423	SCREW 5/16-18 X 1" SHCS ZINC	121	2372100	SCREW-8-18 X 5/8",THDT [2.EA]
10	992-010	SPRING WASHER [2.EA]	62	2263425	SCREW 5/16-18 X 2-1/2" SHCS [2.EA]	122	2261714	WASHER-MAXXUM FT PDL [2.EA]
11	186-094	BRUSH 4" [2.EA]	63	2071541	SPRING-SLEEVE UPPER	123	2261901	BRACKET-CONDUIT AT/MAX
12B	640-014	BRUSH WIRE- BLACK 10 AWG 54 1/2	64	2071535	SPRING SLEEVE, LOWER	124	2263210	BRACKET-CONDUIT ADJUST
12R	640-118	BRUSH WIRE- RED 10 AWG 56 XLP	65	2262706	SPRING, BOWGUARD, NIK	125	2263140	NYLOCK KEEPER
12G	640-315	GROUND WIRE42" (US MOTORS ONLY)	■	2994830	BAG ASSEMBLY-MAXXUM	126	2263466	SCREW-1/4-20 X 2" STL PPH
12F	2218200	FUSE HOLDER (US MOTORS ONLY)	*67	2263431	SCREW 1/4-20 X 3.5" PPH [6.EA]	127	2261238	LEADWIRE MAX
13	738-004	BRUSH PLATE - 4" TERMINAL	*68	2261713	WASHER-1/4" FLAT S/S [6.EA]	128	2020700	TERMINAL RING, 3/8" [2.EA]
14	975-041	SPRING -TORSION [2.EA]	*69	2263103	NUT -NYLOCK JAM 1/4-20 S/S [6.EA]	129	2256300	TIE WRAP-5.5" BLACK
17	701-009	O-RING -THRU BOLT [2.EA]	70	2261505	SPACER, MOTOR REST [6.EA]	130	2263201	CLAMP WIRE HARNESS MICRO [2.EA]
18	701-043	O-RING [2.EA]	71	2263434	SCREW, 8-18 X 1" PPH [2.EA]	131	2332103	SCREW-6-20 X 3/8" THD
19	830-027	SCREW -SELF TREADED 10-32 X 2" [2.EA]	72	2266000	BEARING, BALL-STEEL	133	2254031	SWITCH-MOM/OFF/COM
20	830-096	THRU BOLT 12-24 X 11.56" SS [2.EA]	72A	2266116	BEARING, CARTRIDGE	134	2266412	SWITCH PLATE, FT PEDAL
21	973-025	SPACER -BRUSH PLATE [2.EA]	73	2266001	BEARING, SPLIT RING	135	2332103	SCREW-6-20 X 3/8" THD [2.EA]
22	990-051	WASHER-THRUST, STEEL	74	2261619	COLLAR HALF-ZINC-2 PER	136	2256301	TIE WRAP-5.5' WHITE [2.EA]
23	990-052	WASHER- NYLATRON	75	2263452	SCREW- 1/4-20X3/4 SHCP SS [2.EA]	137	2365107	INSULATING PAD 2.3 X 3.2"
24	2316280	MOTOR ASSEMBLY 36V 4 VARS TXT	76	2260283	CONTROL BOX COVER-MAX	138	2264511	BOTTOM PLATE, MAX 101
	2326285	MOTOR ASEMBLY 36V 4 VARS. TXT US2	77	2372100	SCREW-8-18 X 5/8" THD SS [4.EA]	139	2372100	SCREW-8 X 5/8" SS [5.EA]
25	2032003	TUBE (COMP) 4 HOLE 42"	78	2265663	DECAL COVER, MAXXUM 101	140	2263455	SCREW #12-14 X 1/2" THR FRM [4.EA]
■	1378132	PROPELLER KIT	79	2260150	POINTER DISC TRNSLCNT	141	2265126	BUMPER PAD, FOOT PEDAL [4.EA]
26	2331160	PROPELLER (W.WEDGE 2)	79A	2261733	WASHER-FOAM, INDICATOR	142	2266610	DECAL-ON/OFF SWITCH
27	2091701	WASHER-PROP (LARGE) MAX 101	80	2265800	DECAL-INDICATOR	143	2262535	CONTROL BOX-PLASTIC
28	2093101	NUT-PROP (LARGE) MAX 101	81	2053414	SCREW-8-32 X 1/2" TRI-LOBE [3.EA]	144	2267800	GEAR-INDICATOR [2.EA]
29	2020713	TERMINAL- ADAPTOR MAX50/S	82	2267800	GEAR INDICATOR	145	2262220	INDICATOR-DRIVE
30	2335400	SHRINK TUBE 1/4ODX2" [2EA.]	83	2372100	SCREW-8-18 X 5/8" SS	146	2261905	BRACKET/INDICATOR
31	2262658	PROP PIN	84	2355410	SHRINK TUBE-3/8 OD X 2" [2.EA]	147	2301310	SCREW-8-18 X 1/2" SS
■	2991840	MOUNT, BOW ASSY, W/O BGRD FW STD MAX	85	2232360	PULLEY-CABLE DRUM	148	2264015	LIGHT/INDICATOR
32	2264241	ARM-UPPER FW STD	86	2261730	WASHER-NYLON A/T	149	2263802	STRAP- HOLD DOWN 30.5 VELCRO]
33	2293501	BUSHING, STAINLESS STEEL [4.EA]	87	2996247	TOP BEARING RACE /PINION DRIVE ASSEMBLY	■	2994841	BAG ASSEMBLY- MAXXUM STABILIZER
34	2263500	BOLT, SHOULDER [2.EA]	88	2223468	SCREW-8-32 X 7/16" ZINC PLATE [4.EA]	*150	2268400	SHAFT- SUPPORT
35	2994307	ARM-LOWER ASSEMBLY, STD, FW EXT	89	2262607	PIN- CLEVIS ZN PL	*151	2268401	BUMPER- SHAFT
36	2263912	MOTOR REST STD, MAXXUM	90	2260805	SPRING CLIP ZN PL	*152	2263465	SCREW 1/4-10X1" HHD Z/P
37	2265514	DECAL- MOTOR REST [2.EA]	91	2150400	PULL-GRIP	*153	2261716	WASHER- CONICAL ID.28 SS
38	2773987	BOWPLATE/INSERT- STD FW	92	2151700	WASHER-EYE SHAFT .562"	■	2991556	CLAMP COLLAR ASSEMBLY
39	2251601	ROPE 40" MAXXUM	93	2998200	CIRCUIT BREAKER ASSEMBLY 36V-101 [2.EA]	154	2071550	CLAMP COLLAR "A"
40	2267318	BEARING NYLINER [2.EA]	94	2994496	FOOT PEDAL/PLUG ASSEMBLY	155	2071555	CLAMP COLLAR "B"
41	2261708	WASHER-3/8 X 1/2 X.010" SS [2.EA]	95	2993705	PUSH-BUTTON MAGNET ASSEMBLY	156	2072621	PIN-KNURLED
42	2152610	SPRING-PIN (LOCKBAR) [2.EA]	96	2302732	SPRING-LOWER PEDAL SS	157	2281505	KNOB-CLAMP COLLAR
43	2233600	LOCK BAR- (BOW MOUNT)	97	2260810	CLIP, REED SWITCH	159	2071718	WASHER #10 NYLON RETAINING
44	2233602	LOCK BAR, REAR - ZINC	100	2280115	KNOB-SPEED CONTROL	161	2073102	NUT - HEX 1/4 - 28 SS
45	2152700	SPRING -LOCKBAR	101	2263000	E-RING TRU-ARC#5133-43	162	2071560	SPLIT COLLAR
46	2262703	SPRING STOP	102	2266413	TENSION SCREW PLATE FT	163	2211410	EXTENSION CABLE US2
47	2153602	EYE SHAFT -2LOCKBAR STD PLTD	103	2260511	PIN-PIVOT A/T FT PDL	200	2075120	URETHANE PAD
48	2260506	HINGE-PIN HEADLESS ZINC	104	2992102	FOOT PEDAL BASE/PIN ASSEMBLY			
49	2293811	YOKE, MAXXUM MOUNT POLYPROPYLENE	105	2262301	PULLEY FOOT PEDAL			
50	2261733	WASHER SS [2.EA]	106	2223430	SCREW- #8 X3/4" PPH TYPE 25 SS [4.EA]			

## 2889460 Seal & Oring Kit

\* This item is part of an assembly. This item cannot be sold separately due to machining and /or assembly that is required.

P/N 2274965 REV. S 2-08

Max 101 is 36-volt only!

OPTIONAL BROWN WIRE \*  
SEE BOAT WIRING DIAGRAM  
FIL MARRON OPTIONNEL \*  
ÉQUIPÉS DE SONAR. VOYEZ LE SCHÉMA DE CÂBLAGE DU BATEAU.

SPEED ADJUSTMENT KNOB  
MOLETTE DE REGLAGE DE LA VITESSE

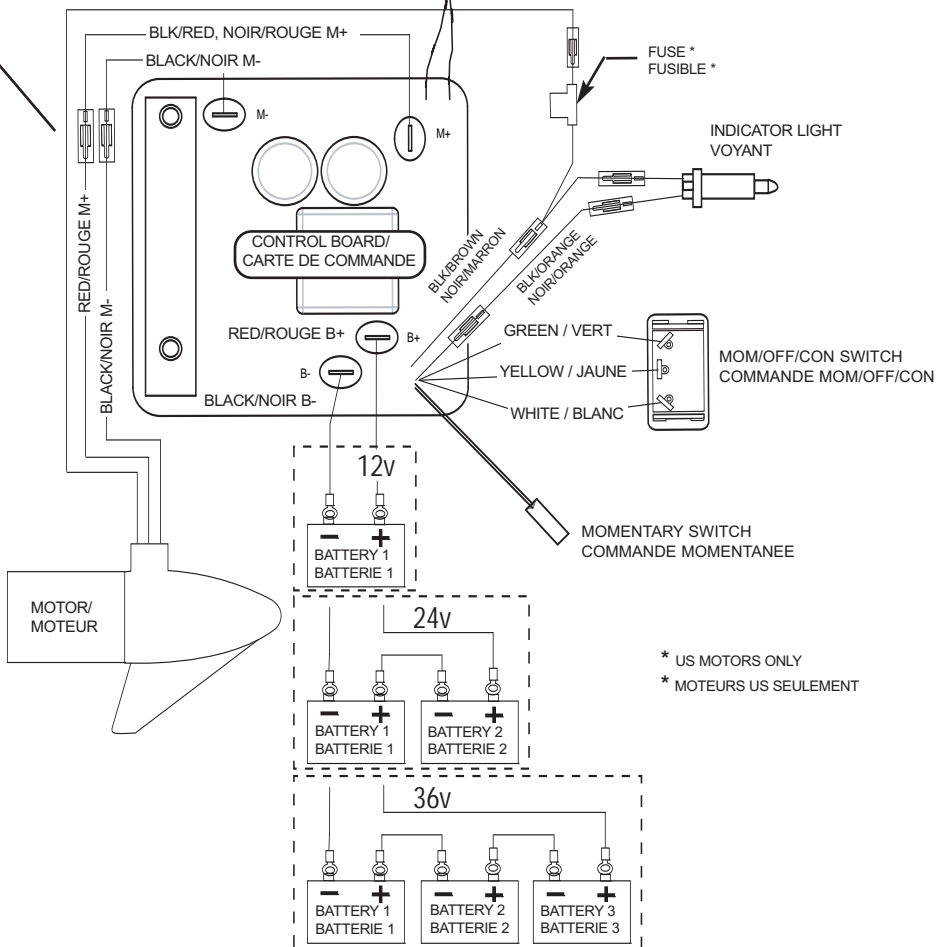

\* US MOTORS ONLY  
\* MOTEURS US SEULEMENT