

Edge/Maxxum 55 / FC
55lbs Thrust
12 Volt 50 Amps
36" & 42" Shaft

for use with "K" serial numbers
2-year warranty from the date of purchase

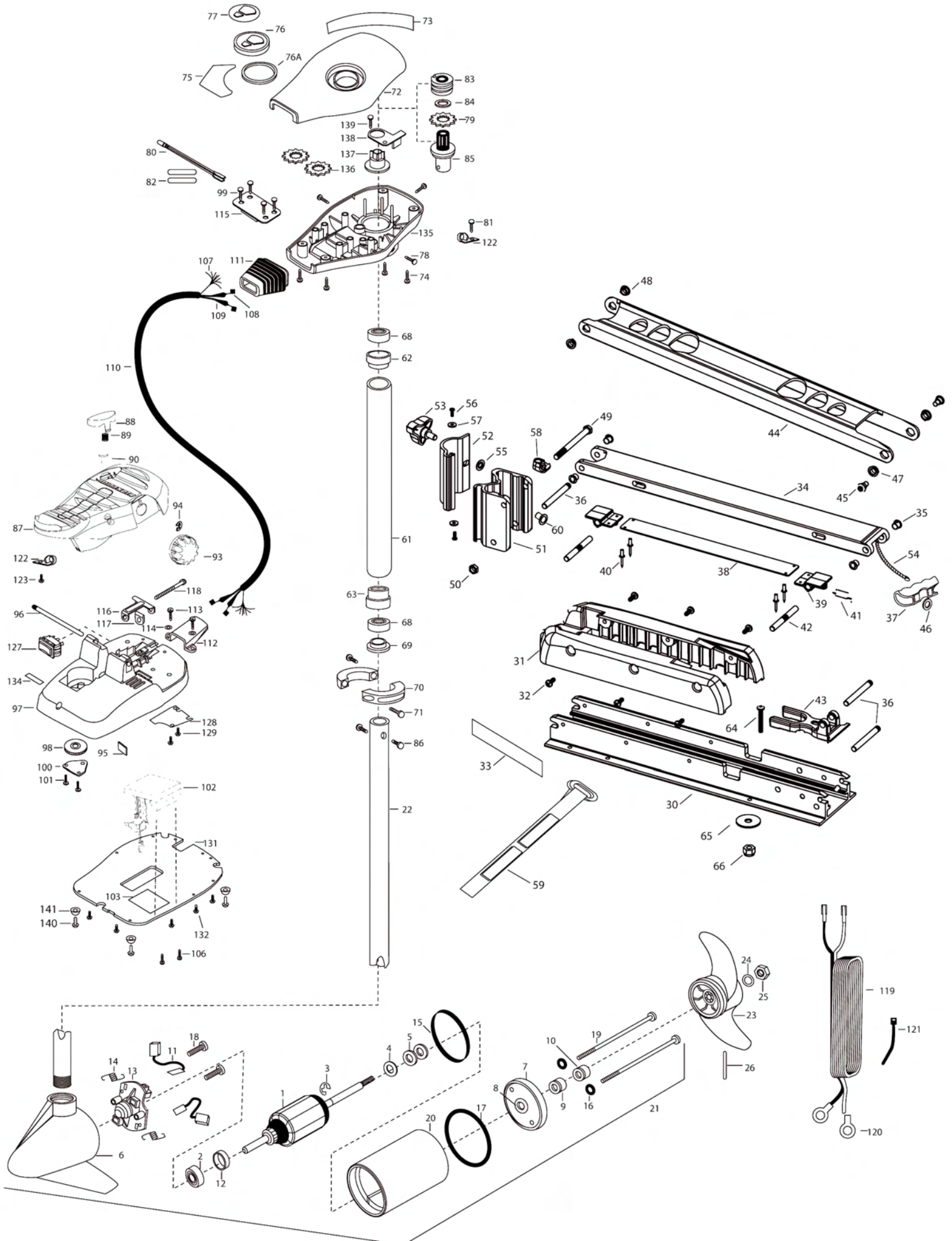

1	2-100-117	ARMATURE ASSEMBLY 12V 3.625	46	2151700	WASHER-EYE SHAFT(.562 OD)	94	2263000	E-RING TRU-ARC#5133-43
2	140-010	BEARING- BALL	47	2267302	BUSHING-LOWER 7/16" ID, SS [2 EA.]	95	2266413	TENSION SCREW PLATE FTPDL
3	788-015	RETAINING RING	48	2267303	BUSHING-UPPER 3/8" IS, SS [2 EA.]	96	2260511	PIN-PIVOT A/T FT PDL
4	990-067	WASHER- STEEL THRUST	49	2263505	BOLT 3/8-16 X 4.25"	97	2774550	FOOT PEDAL BASE/PIN ASSEMBLY
5	990-070	WASHER- NYLATRON [2.EA]	50	2263114	NUT-NYLOCK JAM 3/8-16	98	2262301	PULLEY (FOOT PEDAL)
6	421-065	BRUSH END HOUSING	51	2261872	HINGE BASE, FW	99	2223430	SCREW-8X 3/4 PPH TYPE 25 SS [4.EA]
7	2-400-101	PLAIN END HOUSING ASSEMBLY	52	2261877	HINGE DOOR, FW	100	2266405	COVER-PULLEY (STAMPING)
8	144-049	BEARING -FLANGE	53	2260905	HANDLE-SOFT GRIP	101	2301315	SCREW-8-18 X 1/2 SS [2.EA]
9	880-003	SEAL	54	2251600	ROPE- (31")	102	2344051	CONTROL BOARD ASMBLY-12V
10	880-006	SEAL W/SHEILD	55	2261728	WASHER-RETAINING 3/8	103	2365107	INSULATING PAD 2.3 X 3.2
11	188-036	BRUSH ASSEMBLY [2.EA]	56	2053415	SCREW #8-32 X 3/8" TRI [2 EA.]	106	2223455	SCREW, 10-32 X 1/2" [2.EA]
12	725-050	BRUSH RETENTION	57	2261732	WASHER #8, NYLON [2 EA.]	107	2261220	WIRE HARNESS AT & MAX
13	738-036	BRUSH PLATE W/HOLDER	58	2262310	ROPE GUIDE	108	2267500	CABLE ASSEMBLY-RIGHT (5')
14	975-040	SPRING- TORSION [2.EA]	59	2263805	VELCRO STRAP	109	2267510	CABLE ASSEMBLY-LEFT (5')
15	337-036	GASKET	60	2264703	INSERT-THREADED	110	2265430	CABLE JACKET (5')
16	701-008	O-RING [2.EA]	■	2992015	TUBE W/BEARING RACE ASSEMBLY	111	2265110	BOOT-CONTROL BOX
17	701-081	O-RING	*61	2272066	TUBE OUTER 18" - 4 HOLES	112	2265115	BOOT-FOOT PEDAL BASE
18	830-007	SCREW- SELF THREAD 8-32X1 [2.EA]	62	2266260	BEARING RACE	113	2372100	SCREW-8-18 X 5/8 THD (SS) [2.EA]
19	830-042	THRU BOLT10-32X8.83 [2.EA]	63	2266220	BEARING RACE-STEEL	114	2261714	WASHER-MAXXUM FT PDL [2.EA]
20	2-200-101	CENTER HOUSING FIELD ASSEMBLY	■	2994838	BAG ASSEMBLY-(BOLTS,NUTS,WASHERS)	115	2261901	BRACKET-CONDUIT
21	2097094	MOTOR ASSEMBLY 12V 3.62 VARS	*64	2263462	SCREW 1/4-20 X 2" SS [6.EA]	116	2263210	BRACKET-CONDUIT ADJUSTMENT
22	2032062	TUBE (COMP)W/CSK HOLE-36"	*65	2261713	WASHER-1/4 SS [6.EA]	117	2263104	NYLOCK KEEPER
	2032063	TUBE (COMP)W/CSK HOLE-42"	*66	2263103	NUT 1/4-20 NYLOCK, SS [6.EA]	118	2263463	SCREW-1/4-20 X 2" STL PPH
■	1378131	PROP KIT	68	2266000	BEARING BALL-STEEL [2.EA]	119	2261233	LEADWIRE VARIABLE
*23	2091160	PROPELLER W.WEDGE 2	69	2266115	BEARING CONE	120	2020700	TERMINAL RING, 3/8" [2.EA]
*24	2151726	WASHER-5/16 STD SS	70	2261619	COLLAR HALF-ZINC-2 PER [2.EA]	121	2256300	TIE WRAP-5.5" BLACK
*25	2053101	NUT- NYLOC 5/16 SS	71	2263452	SCREW-1/4-20X3/4 [2.EA]	122	2263201	CLAMP WIRE HARNESS MICRO [2.EA]
*26	2092600	PIN- DRIVE SS	72	2260280	CONTROL BOX COVER-BLK	123	2332103	SCREW-6-20 X 3/8 THD SS
■	2991954	STD-BOWMT FW 30,33,36AT	73	2265507	DECAL- CNTRL BOX TOP/SIDE	127	2254031	SWITCH-MOM/OFF/CON
30	2266502	BOWPLATE, FW, STD, 45"	74	2372100	SCREW-8-18 X 5/8 THD SS [4.EA]	128	2266412	SWITCH PLATE, FT PEDAL
31	2263905	MOTOR REST, BLK	75	2265684	DECAL COVER, 55 EDGE/MAXXUM	129	2332103	SCREW-6-20 X 3/8 THD SS [2.EA]
32	2303430	SCREW 1/4-20 X 5/8" [6 EA.]	76	2260150	POINTER DISC TRNSLCNT RED	130	2256301	TIE WRAP-5.5" WHITE [2.EA]
33	2265667	MOTOR REST DECAL, FW [2 EA.]	76A	2261733	WASHER-FOAM, INDICATOR	131	2264511	BOTTOM PLATE, MAXXUM FT
■	2991700	ARM-LOWER FW ASSEMBLY	77	2265800	DECAL-INDICATOR	132	9953104	SCREW-8 X 1/2" SS [8.EA]
34	2264342	ARM-LOWER, FW, STD	78	2053414	SCREW-#8-32 X 1/2 TRI-LOBE [3.EA]	134	2266610	DECAL-ON/OFF SWITCH
35	2266002	NYLINER 3/8" SHAFT [4 EA.]	79	2267800	GEAR-INDICATOR	135	2262535	CONTROL BOX-PLASTIC
36	2260503	PIVOT PIN [3 EA.]	80	2264015	LIGHT/INDICATOR	136	2267800	GEAR INDICATOR [2.EA]
37	2150400	PULL-GRIP	81	2372100	SCREW-8-18 X 5/8 SS	137	2262220	INDICATOR-DRIVE
■	2993811	LATCH STRAP ASSEMBLY, STD, 45"	82	2355410	SHRINK TUBE-3/8 OD X 2" [2.EA]	138	2261905	BRACKET/INDICATOR
38	2263605	LATCH STRAP, STD, 45"	83	2232360	PULLEY-CABLE DRUM	139	2301310	SCREW-8-18 X 1/2 (SS)
39	2261902	BRACKET-LATCH [2 EA.]	84	2261730	WASHER-NYLON A/T CON B	■	2888460	SEAL & ORING KIT
40	2268602	RIVET 1/8" SS [4 EA.]	85	2996246	TOP BEARING RACE/PINION ASSEMBLY			
41	2262709	SPRING-LATCH PIN	86	2263410	SCREW-8-32 X 5/16 (ZN PL) [2.EA]			
42	2260501	LATCH PIN [2 EA.]	87	2994496	FOOT PEDAL/PLUG ASSEMBLY (AT)			
43	2261544	YOKE-TUBE	88	2993705	PUSH-BUTTON			
44	2264262	ARM-UPPER, FW, STD, 45"	89	2302732	SPRING-LOWER PEDAL SS			
45	2263510	BOLT-SHOULDER, SS [2 EA.]	90	2260810	CLIP, REED SWITCH			
			93	2280115	KNOB-SPEED CONTROL (VAR)			

* This item is part of an assembly. This item cannot be sold separately due to machining and /or assembly that is required.

P/N 2274982 REV. L ECN 31350 2-09

Edge/Maxxum 55 is 12-volt!

OPTIONAL BROWN WIRE *
SEE BOAT WIRING DIAGRAM
FIL MARRON OPTIONNEL *
ÉQUIPÉS DE SONAR. VOYEZ LE SCHÉMA DE CÂBLAGE DU BATEAU.

