

MAX55/FC 42
55 lbs Thrust
12 Volt 50 Amps
42" SHAFT

for use with "K" serial numbers
2-year warranty from the date of purchase

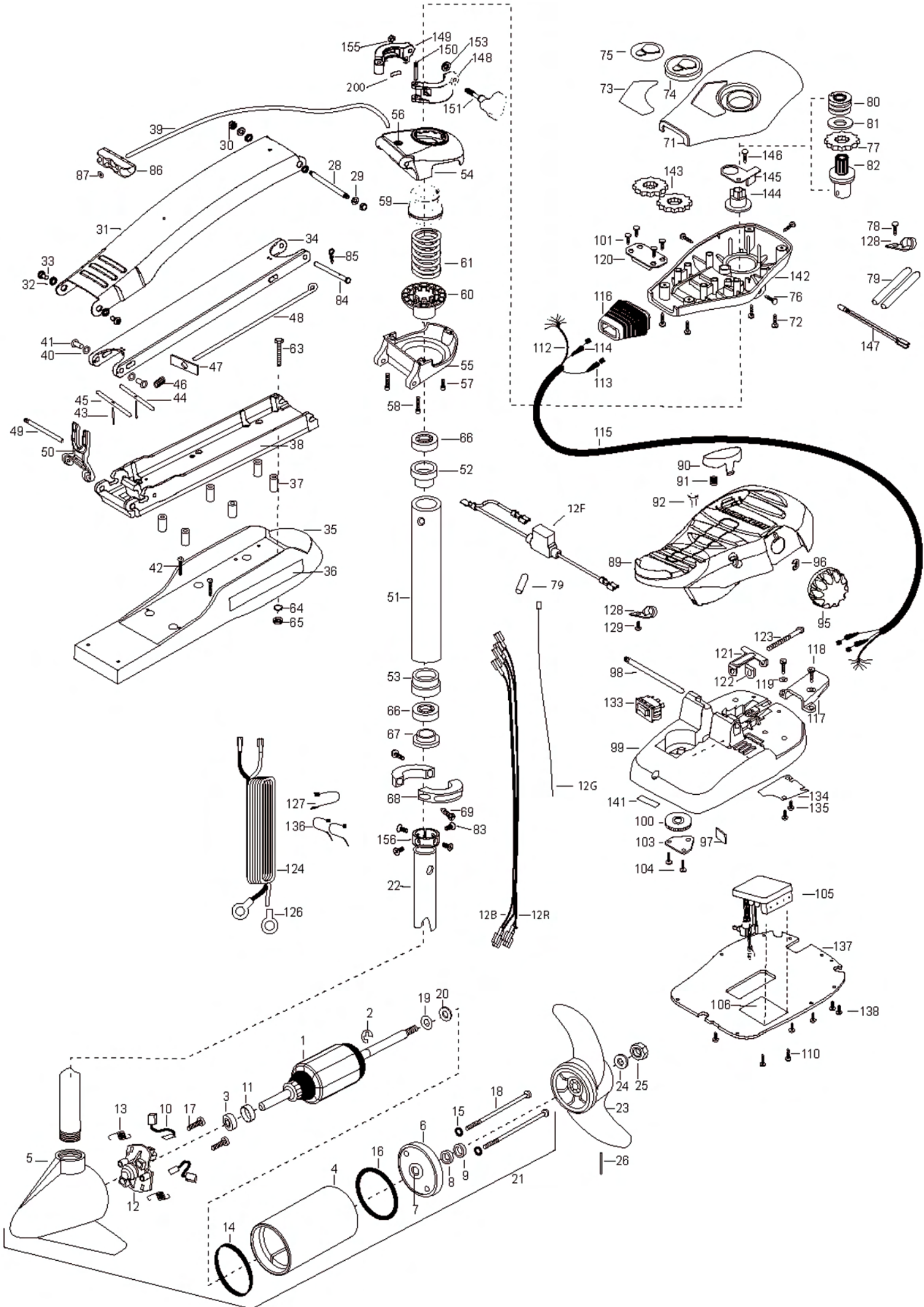

| | | | | | | | | |
|-----|-----------|-------------------------------------------------------------|-----|---------|-----------------------------------------------------|-----|---------|-------------------------------------|
| 1 | 2-100-117 | ARMATURE ASSEMBLY 12V 3.62 FW SW | 47 | 2262703 | SPRING STOP- MAXXUM | 100 | 2262301 | PULLEY- FOOT PEDAL |
| 2 | 788-015 | RETAINING RING | 48 | 2153602 | EYE SHAFT- 2LOCKBAR STD | 101 | 2223430 | SCREW- #8X3/4 PPH TYPE 25 SS [4.EA] |
| 3 | 140-010 | BALL BEARING | 49 | 2260506 | HINGE-PIN HEADLESS ZINC | 103 | 2266400 | COVER- PULLEY |
| 4 | 431-101 | CENTER HOUSING ASSEMBLY 3.62 FW TXT | 50 | 2293811 | YOKE- MAKXUM MOUNT,POLYPROPYLENE | 104 | 2301310 | SCREW- 8-18 X 1/2 [4.EA] |
| 5 | 421-065 | HOUSING BRUSH END 3.62 TXT | ■ | 2772012 | TUBE W/BEARING RACE ASSEMBLY | 105 | 2264053 | CONTROL BOARD ASSEMBLY 12V MAX |
| 6 | 2-400-101 | PLAIN END HOUSING ASSEMBLY | 51 | 2272069 | TUBE OUTER-21" 4 HOLES | 106 | 2365107 | INSULATING PAD (2.3X3.2) |
| 7 | 144-049 | BEARING - FLANGE (SERVICE CENTER ONLY) | 52 | 2266260 | BEARING RACE | 110 | 2223455 | SCREW- 10-32 X 1/2" [2.EA] |
| 8 | 880-003 | SEAL | 53 | 2266220 | BEARING RACE- STEEL | 112 | 2261220 | WIRE HARNESS AT & MAX |
| 9 | 880-006 | SEAL WITH SHIELD | ■ | 2991762 | BOWGUARD ASSEMBLY- FT CTRL,FW | 113 | 2267505 | CABLE ASSEMBLY- RIGHT (5') |
| 10 | 188-036 | BRUSH ASSEMBLY [2.EA] | 54 | 2772319 | BRACKET BASE TOP/EYELET ASSEMBLY | 114 | 2267515 | CABLE ASSEMBLY- LEFT (5') |
| 11 | 725-050 | BRUSH RETENTION- PAPER TUBE | *55 | 2991771 | BRKT BOTTOM/BEARING FW ASSEMBLY | 115 | 2265430 | CABLE JACKET (5') |
| 12 | 738-036 | BRUSH PLATE W/HOLDER | 56 | 2772352 | EYELET- KIT | 116 | 2265110 | BOOT- CONTROL BOX |
| 12B | 640-013 | BRUSH LEAD BLK 10 AWG | 57 | 2263423 | SCREW 5/16-18 X 1" SHCS ZINC | 117 | 2265115 | BOOT- FOOT PEDAL BASE |
| 12R | 640-117 | BRUSH LEAD RED 10 AWG | 58 | 2263425 | SCREW 5/16-18 X 2 1/2 SCHS [2.EA] | 118 | 2372100 | SCREW- 8-18X5/8 THD [2.EA] |
| 12G | 640-315 | GROUND WIRE 42" (US MODELS ONLY) | 59 | 2071541 | SPRING SLEEVE- UPPER | 119 | 2261714 | WASHER- MAXXUM FT PDL [2.EA] |
| 12F | 2218200 | FUSE HOLDER (US MODELS ONLY) | 60 | 2071535 | SPRING SLEEVE- LOWER | 120 | 2261901 | BRACKET- CONDUIT |
| 13 | 975-040 | SPRING - TORSION [2.EA] | 61 | 2262706 | SPRING- BOWGUARD, NIK PL | 121 | 2263210 | BRACKET- CONDUIT ADJUST |
| 14 | 337-036 | GASKET | ■ | 2994830 | BAG ASSEMBLY- MAXXUM | 122 | 2263104 | NYLOCK KEEPER |
| 15 | 701-008 | O-RING, THRU-BOLT [2.EA] | *63 | 2263431 | SCREW- 1/4-20 X 3.5 PPH [6.EA] | 123 | 2263463 | SCREW- 1/4-20X2" STL PPH |
| 16 | 701-081 | O-RING | *64 | 2261713 | WASHER- 1/4 FLAT S/S [6.EA] | 124 | 2261233 | LEADWIRE- VARIABLE |
| 17 | 830-007 | SCREW-8-32 [2.EA] | *65 | 2263103 | NUT- 1/4-20 NYLOCK-JAM SS [6.EA] | 126 | 2020700 | TERMINAL RING- 3/8" [2.EA] |
| 18 | 830-042 | THRU-BOLT 10-32X8.83 [2.EA] | 66 | 2266000 | BEARING BALL- STEEL [2.EA] | 127 | 2256300 | TIE WRAP- 5.5" BLACK |
| 19 | 990-067 | WASHER- STEEL THRUST | *67 | 2266115 | BEARING CONE | 128 | 2263201 | CLAMP WIRE HARNESS MICRO [2.EA] |
| 20 | 990-070 | WASHER- NYLATRON [2.EA] | *68 | 2261619 | COLLAR HALF- ZINC [2.EA] | 129 | 2332103 | SCREW- 6-20X3/8 THD (SS) |
| 21 | 2097094 | MOTOR ASSEMBLY 12V FW VARS 55# | *69 | 2263452 | SCREW- 1/4-20X3/4 [2.EA] | 133 | 2254031 | SWITCH- MOM/OFF/CON |
| 22 | 2032003 | TUBE-COMPOSITE 4 HOLE 42" | 71 | 2260283 | CONTROL BOX COVER- MAXXUM | 134 | 2266412 | SWITCH PLATE- FT PEDAL |
| ■ | 1378131 | PROPELLER KIT | 72 | 2372100 | SCREW- 8-18 X 5/8 THD [4.EA] | 135 | 2332103 | SCREW- 6-20X3/8 THD SS [2.EA] |
| 23 | 2091160 | PROPELLER W.WEDGE 2 | 73 | 2265656 | DECAL- COVER MAX 55/FC | 136 | 2256301 | TIE WRAP- 5.5" WHITE [2.EA] |
| 24 | 2151726 | WASHER-5/16 SS | 74 | 2260150 | POINTER DISC TRNSLCNT RED | 137 | 2266414 | BOTTOM PLATE- MAX FOOT PEDAL |
| 25 | 2053101 | NUT-PROP NYLOC | 74A | 2261733 | WASHER-FOAM, INDICATOR | 138 | 9953104 | SCREW-8 X 1/2" (SS) [5.EA] |
| 26 | 2092600 | PIN-DRIVE | 75 | 2265800 | DECAL- INDICATOR | 141 | 2266610 | DECAL- ON/OFF SWITCH |
| 28 | 2262605 | PIN- BWGRD UPPER THREADED ZP | 76 | 2053414 | SCREW- 8-32 X 1/2 TRI-LOBE [3. EA] | 142 | 2262535 | CONTROL BOX- PLASTIC |
| 29 | 9908236 | WASHER- 1/4 FLAT ZINC [2.EA] | 77 | 2267800 | GEAR- INDICATOR | 143 | 2267800 | GEAR- INDICATOR [2.EA] |
| 30 | 2223100 | NUT- TENSION 5/16-18 SS [2.EA] | 78 | 2372100 | SCREW- 8-18 X 5/8" | 144 | 2262220 | INDICATOR- DRIVE |
| ■ | 2991840 | MOUNT- BOW ASSY, W/O BGRD, STD FW | 79 | 2355410 | SHRINK TUBE- 3/8 OD X 2" [2.EA] | 145 | 2261905 | BRACKET/INDICATOR |
| 31 | 2264241 | ARM-UPPER STD FW | 80 | 2232360 | PULLEY- CABLE DRUM | 146 | 2301310 | SCREW- 8-18X1/2" |
| 32 | 2293501 | BUSHING- STAINLESS STEEL [4.EA] | 81 | 2261730 | WASHER- NYLON A/T CON | 147 | 2264015 | LIGHT/INDICATOR |
| 33 | 2263500 | BOLT- SHOULDER MAXXUM [2.EA] | 82 | 2996247 | TOP BEARING RACE /PINION DRIVE | ■ | 2991550 | CLAMP COLLAR ASSEMBLY |
| 34 | 2994307 | ARM-LOWER ASSEMBLY,STD,FW,EXTRA [INCLUDES 39, 43-47, 86,87] | 83 | 2223468 | SCREW- 8-32 X 7/16 [7.EA] | 148 | 2071550 | CLAMP COLLAR "A" |
| 35 | 2263912 | MOTOR REST (STD) FW | 84 | 2262607 | PIN- CLEVIS ZP MAXXUM BWGRD | 149 | 2071555 | CLAMP COLLAR "B" |
| 36 | 2265514 | DECAL- MAXXUM MOTOR REST [2.EA] | 85 | 2260805 | CLIP- SPRING ZP MAX BG | 150 | 2072621 | PIN-KNURLED |
| 37 | 2261505 | SPACER- MOTOR REST [6.EA] | 86 | 2150400 | PULL- GRIP | 151 | 2281505 | KNOB-CLAMP COLLAR |
| 38 | 2773987 | BOWPLATE- W/INSERT | 87 | 2151700 | WASHER- EYE SHAFT(.562 OD) | 153 | 2071718 | WASHER #10 NYLON RETAINING |
| 39 | 2251601 | ROPE (40"), MAXXUM MOUNT | 89 | 2994496 | FOOT PEDAL/PLUG ASSEMBLY | 155 | 2073102 | NUT - HEX 1/4 - 28 SS |
| 40 | 2261708 | WASHER- 3/8X1/2X.010 SS [2.EA] | 90 | 2993705 | PUSH- BUTTON MAGNET ASSY | 156 | 2071560 | SPLIT COLLAR |
| 41 | 2267318 | BEARING NYLINER [2.EA] | 91 | 2302732 | SPRING- LOWER PEDAL | 200 | 2075120 | URETHANE PAD |
| 42 | 2263434 | SCREW, 8-18X1" PPH [2.EA] | 92 | 2260810 | CLIP, REED SWITCH | | | |
| 43 | 2152610 | SPRING- PIN LOCKBAR [2.EA] | 95 | 2280115 | KNOB- SPEED CONTROL (VAR) | | | |
| 44 | 2233600 | LOCK BAR- BOW MOUNT | 96 | 2263000 | E-RING THU-ARC | | | |
| 45 | 2233602 | LOCK BAR REAR - ZINC | *98 | 2260511 | TENSION SCREW PLATE FTPEDAL | | | |
| 46 | 2152700 | SPRING- LOCKBAR CAD.PLTD | 99 | 2992102 | PIN- PIVOT A/T FT PDL FT PEDAL BASE/PIN ASSEMBLY | | | |

* This item is part of an assembly. This item cannot be sold separately due to machining and /or assembly that is required.

Maxxum 55 is 12-volt only!

OPTIONAL BROWN WIRE *
SEE BOAT WIRING DIAGRAM
FIL MARRON OPTIONNEL *
ÉQUIPÉS DE SONAR. VOYEZ LE SCHÉMA DE CÂBLAGE DU BATEAU.

