

**80 MAXXUM**  
**80 LBS THRUST**  
**24 VOLT 56 AMPS**  
**42" OR 36" SHAFT**

for use with "K" serial numbers  
2-year warranty from the date of purchase

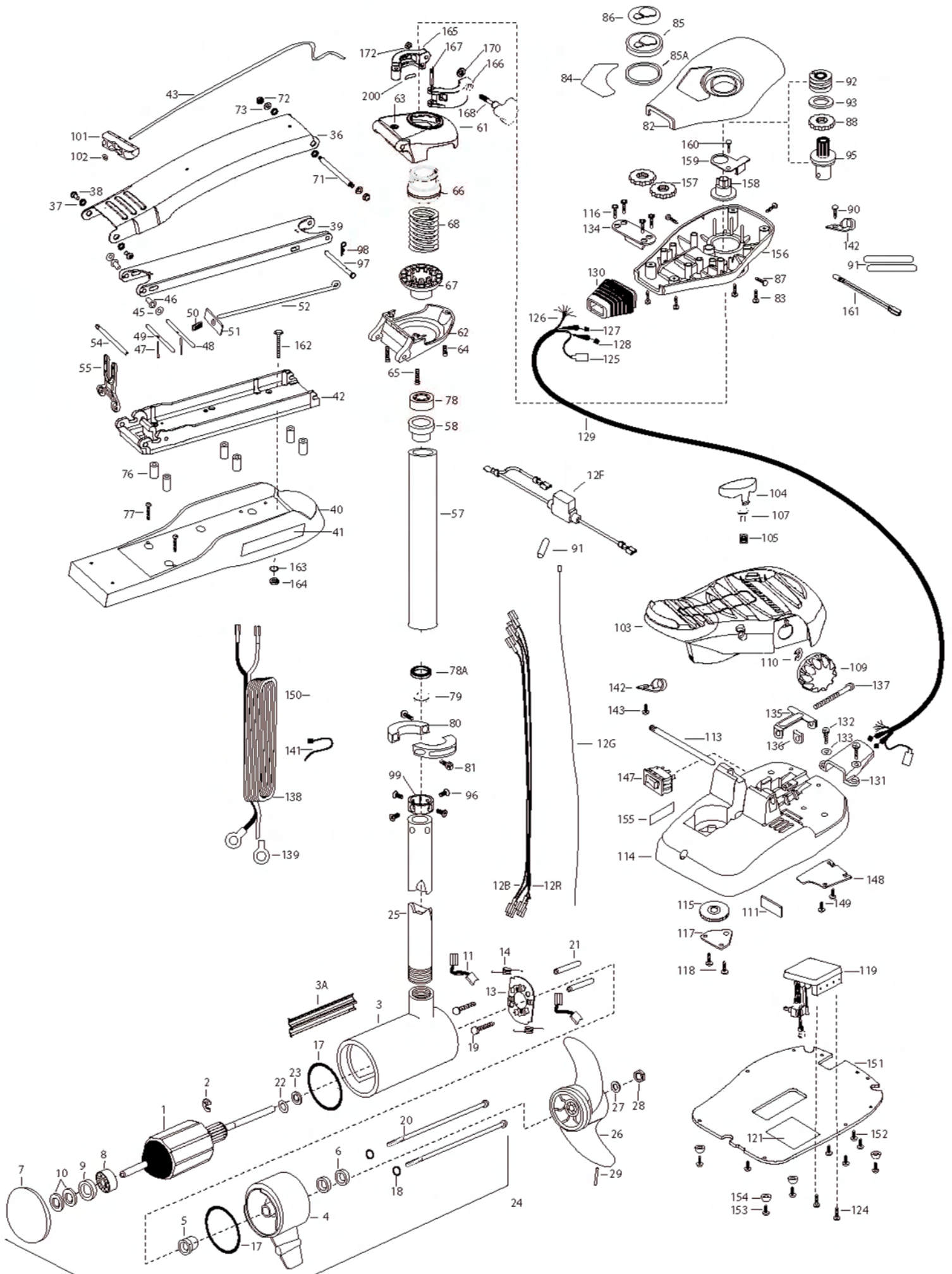

1	2-100-214	ARMATURE ASSEMBLY 24V 4"	57	2272085	TUBE -OUTER 21" 4 HOLES [FOR 42"]	118	2301310	SCREW-8-18 X 1/2 SS [2.EA]
2	788-040	RETAINING RING		2272087	TUBE -OUTER 18" 4 HOLES [FOR 36"]	119	2264054	CONTROL BOARD ASSY 24-36V MAX
3	2-200-160	HOUSING ASSEMBLY CENTER 4.0	58	2266260	BEARING RACE-(565T)	121	2365107	INSULATING PAD 2.3 X 3.2
3A	582-013	CLIP, RETAINING, US2				124	2263455	SCREW, 10-32 X 1/2 [2.EA]
4	2-300-160	BRUSH END HOUSING ASSEMBLY	■	2991762	BOWGUARD ASSEMBLY-FT CTRL,MAX	125	2211410	EXTENSION CABLE US2
5	144-017	BEARING- FLANGE (SERVICE ONLY)	61	2772319	BRACKET BASE TOP/EYELETASSEMBLY	126	2261220	WIRE HARNESS AT & MAX 82.5
6	880-025	SEAL [2.EA]	62	2991771	BRKT BOTTOM/BEARING FW ASSEMBLY	127	2267505	CABLE ASSEMBLY-RIGHT 5'
7	421-276	PLAIN END HOUSING ASSEMBLY	63	2262315	EYELET KIT -ROPE	128	2267515	CABLE ASSEMBLY-LEFT 5'
	9421-284	PLAIN END HOUSING ASSEMBLY 4.0 US2	64	2263423	SCREW 5/16-18 X 1" SHCS ZINC	129	2265430	CABLE JACKET 5'
8	140-010	BALL BEARING	65	2263425	SCREW 5/15-18 X 2-1/2" SHCS [2.EA]	130	2265110	BOOT-CONTROL BOX
9	990-045	THRUST SPACER	66	2071541	SPRING-SLEEVE UPPER	131	2265115	BOOT-FOOT PEDAL BASE
10	992-010	SPRING WASHER [2.EA]	67	2071535	SPRING SLEEVE, LOWER	132	2372100	SCREW-8-18 X 5/8 THD SS [2.EA]
11	186-094	BRUSH [2.EA]	68	2262712	SPRING, BOWGUARD, NIK PL	133	2261714	WASHER-MAXXUM PT PDL [2.EA]
12B	640-013	BRUSH LEAD BLK 10 AWG 51-1/2	71	2262605	PIN- THREADED	134	2261901	BRACKET-CONDUIT AT/MAX
12R	640-117	BRUSH LEAD RED 10 AWG 53	72	2223100	NUT- NYLOC [2.EA]	135	2263210	BRACKET-CONDUIT ADJUSTMENT
12G	640-315	GROUND WIRE 42" (US MOTORS ONLY)	73	9908236	WASHER [2.EA]	136	2263401	NYLOCK KEEPER
12F	2218200	FUSE HOLDER (US MOTORS ONLY)	■	2994832	BAG ASSEMBLY	137	2263463	SCREW-1/4-20 X 2 STL PPH
13	738-004	BRUSH PLATE 4"	*76	2261505	SPACER, MOTOR REST [6.EA]	138	2261233	LEADWIRE VARIABLE
14	975-041	SPRING- TORSION [2.EA]	*77	2263434	SCREW, 8-18 X 1 PPH SS [2.EA]	139	2020700	TERMINAL RING, 3/8 [2.EA]
17	701-043	O-RING [2.EA]	78	2266000	BEARING, BALL-STEEL	141	2256300	TIE WRAP-5.5 BLACK
18	701-009	O-RING —THRU BOLT [2.EA]	78A	2266116	BEARING, CARTRIDGE	142	2263201	CLAMP WIRE HARNESS MICRO [2.EA]
19	830-027	SCREW -SELF THREAD 10-32X2 [2.EA]	79	2266001	BEARING, SPLIT RING	143	2332103	SCREW-6-20 X 3/8 THD SS
20	830-094	THRU BOLT 12-24X10.31 [2.EA]	80	2771617	COLLAR HALF-ZINC-2 PER- KIT	147	2254031	SWITCH-MOM/OFF/COM
21	973-025	SPACER- BRUSH PLATE [2.EA]	81	2263452	SCREW-1/4-20 X 3/4 SHCS SS [2.EA]	148	2266412	SWITCH PLATE, PT PEDAL
22	990-051	WASHER- STEEL	82	2260283	CONTROL BOX COVER-MAXXUM	149	2332103	SCREW-6-20 X 3/8 THD SS [2.EA]
23	990-052	WASHER- NYLATRON	83	2372100	SCREW-8-18 X 5/8 THD [4.EA]	150	2256301	TIE WRAP-5.5 WHITE [2.EA]
24	2316216	MOTOR ASSEMBLY 24V 4" VARS	84	2265644	DECAL COVER, MAXXUM 80	151	2264511	BOTTOM PLATE, MAXXUM PT
	2326220	MOTOR ASSEMBLY 24V 4" VARS- SONAR		2265694	DECAL COVER, MAXXUM 80 US2	152	9953104	SCREW-8 X 1/2 PPH SS [5.EA]
25	2032003	TUBE COMP W/4 HOLE 42"	85	2260150	POINTER DISC TRNSLCNT RED	153	2263455	SCREW #12 [4.EA]
	2032001	TUBE COMP W/4 HOLE 36"	85A	2261733	WASHER-FOAM, INDICATOR	154	2265126	BUMPER [4.EA]
■	1378132	PROPELLER KIT	86	2265800	DECAL-INDICATOR	155	2266610	DECAL-ON/OFF SWITCH
26	2331160	PROPELLER W.WEDGE 2	87	2053414	SCREW-#8-32 X 1/2 TRI-LOBE [3.EA]	156	2262535	CONTROL BOX-PLASTIC AT'S
27	2091701	WASHER-PROP LARGE	88	2267800	GEAR-INDICATOR	157	2267800	GEAR-INDICATOR [2.EA]
28	2093101	NUT-PROP NYLOCK SS	90	2372100	SCREW-8-18 X 5/8 SS	158	2262220	INDICATOR-DRIVE
29	2262658	PIN-DRIVE SS	91	2355410	SHRINK TUBE-3/8 OD X 2- [3.EA]	159	2261905	BRACKET/INDICATOR
■	2991840	MOUNT,BOW ASSY, FW STD, W/O BGRD	92	2232360	PULLEY-CABLE DRUM	160	2301310	SCREW-8-18 X 1/2 SS
36	2264241	ARM UPPER-FW STD	93	2261730	WASHER-NYLON	161	2264015	LIGHT/INDICATOR
37	2293501	BUSHING, STAINLESS STEEL [4.EA]	95	2996247	PINION/RACE ASSEMBLY	■	2994830	BAG ASSEMBLY-MAXXUM
38	2263500	BOLT, SHOULDER MAXXUM [2.EA]	96	2223468	SCREW-8-32 X 7/16 ZN PL [4.EA]	*162	2263431	SCREW 1/4-20 X 3.5 PPH [6.EA]
39	2774315	ARM-LOWER ASSEMBLY,STD,FW,EXT	97	2262607	PIN- CLEVIS ZN	*163	2261713	WASHER-1/4 FLAT S/S [6.EA]
40	2263912	MOTOR REST STD MAXXUM	98	2260805	SPRING CLIP ZN	*164	2263103	NUT-1/4-20 NYLOCK-JAM [6.EA]
41	2265514	DECAL-MAXXUM,MOTOR REST [2.EA]	99	2071560	SPLIT COLLAR	■	2991550	CLAMP COLLAR ASSEMBLY
42	2773987	BOWPLATE- FW STD MACH/INSERT	101	2150400	PULL-GRIP	165	2071550	CLAMP COLLAR "A"
43	2251601	ROPE 40" MAXXUM MOUNT	102	2151700	WASHER-EYE SHAFT .562 OD	166	2071555	CLAMP COLLAR "B"
45	2261708	WASHER-3/8X1/2X.016 [2.EA]	103	2994496	FOOT PEDAL/PLUG ASSEMBLY	167	2072621	PIN-KNURLED
46	2267318	BEARING NYLINER- [2.EA]	104	2993705	PUSH-BUTTON MAGNET ASSEMBLY	168	2281505	KNOB-CLAMP COLLAR
47	2152610	SPRING-PIN LOCKBAR [2.EA]	105	2302732	SPRING-LOWER PEDAL SS	170	2071718	WASHER #10 NYLON RETAINING
48	2233600	LOCK BAR- BOW MOUNT	107	2260810	CLIP, REED SWITCH	172	2073102	NUT - HEX 1/4 - 28 SS
49	2233602	LOCK BAR- REAR ZINC	109	2280115	KNOB-SPEED CONTROL VAR	200	2075120	URETHANE PAD
50	2152700	SPRING-LOCKBAR CAD.PLT	110	2263000	E-RING TRU-ARC#5133-43			
51	2262703	SPRING STOP	*111	2266413	PLATE -TENSION SCREW FTPED.			
52	2153602	EYE SHAFT-2LOCKBAR STD-PLTD	113	2260511	PIN-PIVOT A/T PT PDL			
54	2260506	HINGE-PIN HEADLESS ZINC	114	2774550	FT PEDAL BASE/PIN ASSEMBLY			
55	2293811	YOKE,MAX MNT-POLYPROPYLENE	115	2262301	PULLEY- FOOT PEDAL			
■	2772085	TUBE W/BEARING RACE ASSEMBLY 42"	116	2223430	SCREW- 8X3/4 PPH TYPE 25 SS [4.EA]			
	2772087	TUBE W/BEARING RACE ASSEMBLY 36"	117	2266400	COVER-PULLEY STAMPING			

\* This item is part of an assembly. This item cannot be sold separately due to machining and /or assembly that is required.

P/N 2274963 REV. W ECN 31343

2-09

Maxxum 80 is 24-volt only!

OPTIONAL BROWN WIRE \*  
SEE BOAT WIRING DIAGRAM  
FIL MARRON OPTIONNEL \*  
ÉQUIPÉS DE SONAR. VOYEZ LE SCHÉMA DE CÂBLAGE DU BATEAU.

