

AUTOPILOT 70
70 LBS THRUST
24 VOLT 42 AMPS
54" OR 60" SHAFT

for use with "L" serial numbers
2-year warranty

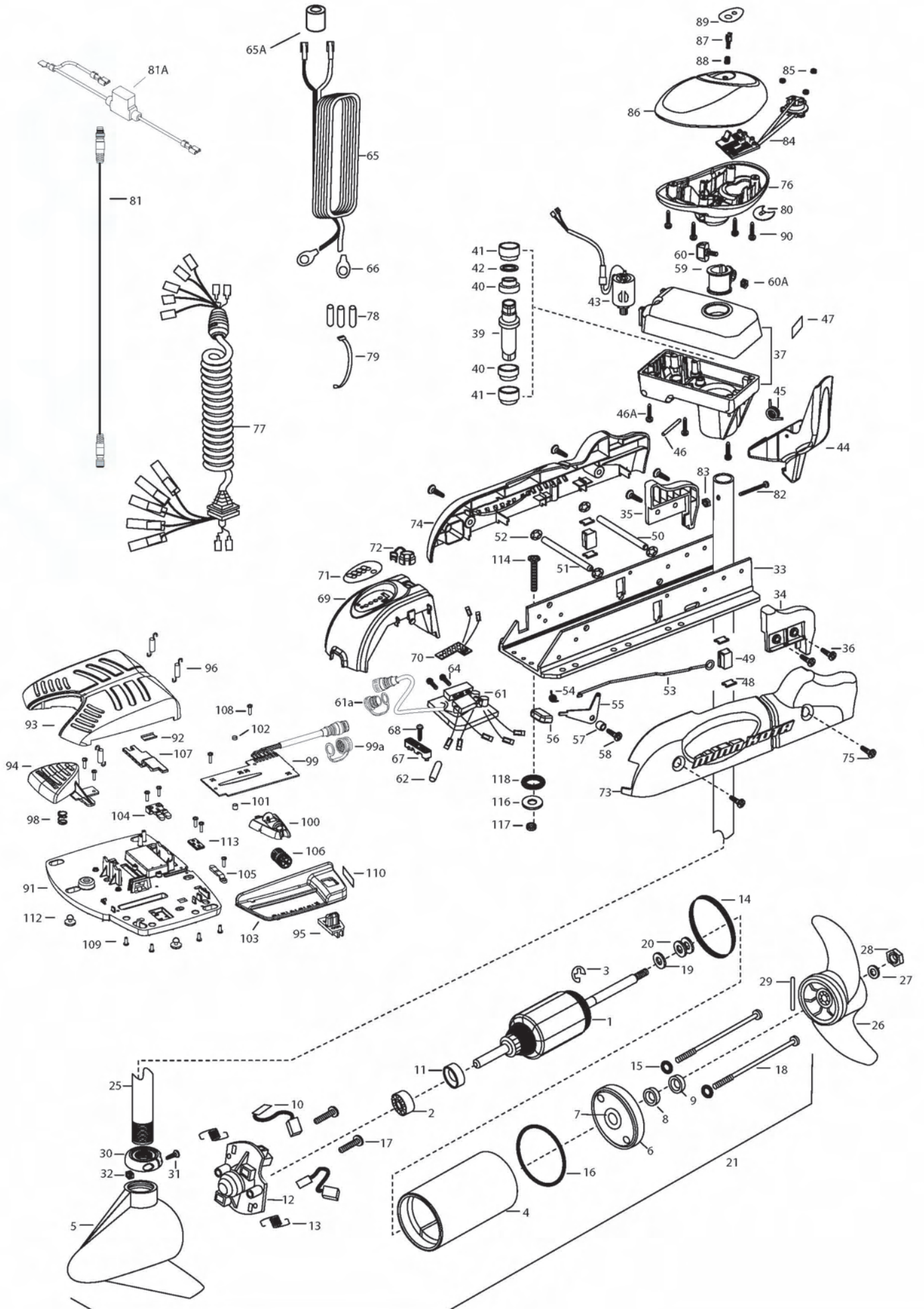

In the U.S.A., replacement parts may be ordered directly from MINN KOTA Parts Dept., 121 Power Drive,P.O. Box 8129 Mankato, Minnesota 56002-8129. In Canada, parts may be ordered from any of the Canadian Authorized Service Centers shown on the enclosed list. Be sure to provide the MODEL and SERIAL numbers of your motor when ordering parts. Please use the correct part numbers from the parts list. Payment for any parts ordered from the MINN KOTA parts department, may be by cash, personal check, Discover Card, MasterCard or VISA. To order, call 1-800-227-6433 or FAX 1-800-527-4464.

Fuera de los Estados Unidos, consultar la lista anexa para ubicar el Centro de servicio autorizado MINN KOTA. No dejar de incluir el número del MODELO y el número de SERIE del motor para el cual se solicitan las piezas. Usar siempre los números de pieza correctos indicados en la lista de piezas.

1	2-100-119	ARMATURE ASSEMBLY 24V VARS TXT	*41	2307305	BUSHING- OUTER [2.EA]	80	2224702	INSERT- PLUG
2	140-010	BALL BEARING	*42	2304603	O-RING		2224700	INSERT- PLUG US2
3	788-015	RETAINING RING	43	2307050	MOTOR- DRIVE HOUSING HIGH SPD	81	2211415	UNIVERSAL SONAR II EXTENSION CABLE
4	2-200-005	HOUSING ASSEMBLY CENTER 3.62 TXT	44	2307201	LATCH HANDLE PD/AP	81A	2218200	FUSE HOLDER, US2 MOTORS ONLY
5	421-065	HOUSING -BRUSH END 3.62 TXT	45	2302750	SPRING- LATCH TORSION PD/AP	82	2333102	SCREW-10-24 X 1-3/4 PPH Z/P
	9421-168	HOUSING BRUSH END 3.62 SONAR 54"/60"	46	2302627	PIN- ROLL ZINC	83	2333101	NUT-HEX 10-24 ZCP
6	2-400-101	PLAIN END HOUSING ASSEMBLY 3.625	46A	2303407	SCREW - DRIVE HOUSING [6 EA]	84	2994014	CNTRL BRD/CMPSS ASSMBLY-AP
7	144-049	BEARING - FLANGE (SERVICE ONLY)	47	2305564	DECAL-STOW/DEPLOY	85	2302960	GROMMET-COMPASS [3.EA]
8	880-003	SEAL	48	2305110	PAD-PIVOT SUPT [4.EA]	86	2300237	CONTROL BOX COVER
9	880-006	SEAL WITH SHIELD	49	2305103	PIVOT PAD- NEW MTR'L [2.EA]	87	2304082	ACTUATOR- SWITCH ON/OFF A/P
10	188-037	BRUSH ASSEMBLY [2.EA]	50	2300500	PIN-LATCH	88	2302752	SPRING- ACTUATOR PD/AP SS
11	725-035	BRUSH RETENTION- PAPER TUBE	51	2300510	PIN-PIVOT	89	2305653	DECAL- COVER 70 PD/ AP
12	738-036	BRUSH PLATE W/HOLDER	52	2013100	NUT-SPEED [4.EA]		2305654	DECAL - COVER 70 PD / AP / US
13	975-040	SPRING - TORSION [2.EA]	53	2303612	ROD-RELEASE RT/AP S	90	2372100	SCREW-8-18 X 5/8 THD CUT [4.EA]
14	337-036	GASKET	54	2322700	SPRING-RELEASE LEVER	■	2994725	FOOT PEDAL ASSEMBLY
15	701-008	O-RING, THRU-BOLT [2.EA]	55	2303710	LEVER-RELEASE	91	2304505	FOOT PEDAL BASE
16	701-081	O-RING	56	2300101	RELEASE-KNOB	92	2308501	WEAR PLATE FOOT PDL
17	830-007	SCREW-8-32 [2.EA]	57	2301700	SPACER-RELEASE LEVER	93	2300255	FOOT PEDAL, CORDED UPPER
18	830-008	THRU-BOLT 10-32X9.2 [2.EA]	58	2303430	SCREW-1/4-20 X 5/8	94	2303723	BUTTON, MOMENTARY
19	990-067	WASHER- STEEL THRUST	59	2031522	COLLAR- DRIVE (W/INSERT)	95	2303722	BUTTON, MOM/CON
20	990-070	WASHER - NYLATRON [2.EA]	60	2011365	SCREW-COLLAR/NEW KNOB	96	2302730	SPRING-LONG-UPPER PEDAL [3.EA]
21	2096031	MOTOR ASSEMBLY 24V 3.62 54"	60A	2323104	NUT	98	2302732	SPRING-LOWER PEDAL
	2096032	MOTOR ASSEMBLY 24V 3.62 60"	61	2304063	CONTROL BOARD ASSEMBLY- 24V PD/AP	99	2304052	CONTROL BOARD ASSEMBLY-FT PDL
	2106035	MOTOR ASSEMBLY US2 24V 3.62 54"	61A	2320208	DUST PLUG	99A	2320207	DUST CAP
	2106046	MOTOR ASSEMBLY US2 24V 3.62 60"	62	2355410	SHRINK TUBE-3/8 ODX2	100	2308620	SLIDER, SPEED
25	2032076	TUBE-CARBON COMPOSITE 54"	64	2303434	SCREW-8-32 X 5/8 [3.EA]	101	2308409	MAGNET, 1/4 X 1/4
	2032074	TUBE-CARBON COMPOSITE 60"	65	2090651	LEADWIRE IOGA 44"	102	2778408	MAGNET, 1/4 X 1/8
■	1378131	PROPELLER KIT	65A	2307310	BEAD - FERRITE (CE MODELS ONLY)	103	2300252	COVER, SPEED SELECTOR
26	2091160	PROPELLER W/WEDGE 2	66	2020700	TERMINAL RING [2.EA]	104	2308606	SWITCH, DOUBLE FINGER
27	2151726	WASHER-5/16 SS	67	2321310	STRAIN RELIEF- BRACKET PD/AP	105	2308608	SWITCH, SINGLE FINGER
28	2053101	NUT-PROP NYLOC	68	2323405	SCREW-1/4-20 X 5/8	106	2307900	WHEEL, SPEED
29	2092600	PIN-DRIVE	69	2306555	HOUSING- CENTER PD/AP	107	2308625	SLIDER, STEERING
30	2301545	COLLAR- LATCH PD/AP	70	2074071	BATTERY GAUGE - 24 VOLT	108	2302100	SCREW-6-20 X 1/2 [9.EA]
31	2303434	SCREW- 8-32X5/8 MACH PHCR	71	2316605	DECAL, BATTERY GAUGE	109	2372103	SCREW-6.20 X 3/8 [4.EA]
32	2303112	NUT 8-32 NYLOC SS	72	2302935	STRAIN RELIEF-DR. HOUSING	110	2316600	DECAL, ON/OFF SWITCH
33	2301936	EXTRUSION- BASE MACHINED	73	2303960	SIDEPLATE (RIGHT)PD MK	112	2994859	BAG ASSEMBLY- 5 RUBBER BUMPERS
34	2303932	MOTOR REST- RIGHT 3-5/8	74	2303965	SIDEPLATE(LEFT)PD MK	113	2302907	STRN RLF PD FP
35	2303937	MOTOR REST- LEFT 3-5/8	75	2303430	SCREW-1/4-20 X 5/8- [4.EA]	■	2994864	BAG ASSEMBLY- (BOLT,NUT,WASHERS)
36	2303430	SCREW 1/4-20X5/8 SELF TAP [4.EA]	76	2302515	CONTROL BOX PD/AP	*114	2263462	BOLT-MOUNTING-1/4X2 W/STG [6.EA]
37	2771826	DRIVE HOUSING PD V2	77	2991285	COIL CORD WSTRAIN RELIEF 48, 54"	*116	2261713	WASHER-1/4 [6.EA]
■	2882011	BUSHING/ OUTSHAFT KIT (INCLUDES 39-42)		2991287	COIL CORD WSTRAIN RELIEF 60"	*117	2263103	NUT NYLOK 1/4-20 MTG [6.EA]
*39	2302010	DRIVE HOUSING OUTPUT SHAFT	78	2065400	WIRE INSULATOR-LGE 1-3/4 [3.EA]	*118	2301720	WASHER-MOUNTING RUBBER [6.EA]
*40	2307304	BUSHING- INNER [2.EA]	79	2256300	TIE WRAP-5" BLACK	■	2888460	SEAL & ORING KIT

* This item is part of an assembly. This item cannot be sold separately due to machining and /or assembly that is required.

P/N 2314958

REV. R ECN 31057 10-09

12-24 VOLT MODELS MODÈLES 12-24 V

THIS IS A UNIVERSAL MULTI-VOLTAGE DIAGRAM. DOUBLE CHECK YOUR MOTORS VOLTAGE FOR PROPER CONNECTIONS
CECI EST UN SCHEMA À TENSION MULTIPLE UNIVERSEL. REVÉRIFIEZ LA TENSION DE VOTRE MOTEUR POUR BIEN LE BRANCHER.

AutoPilot 70 is 24-volt only!

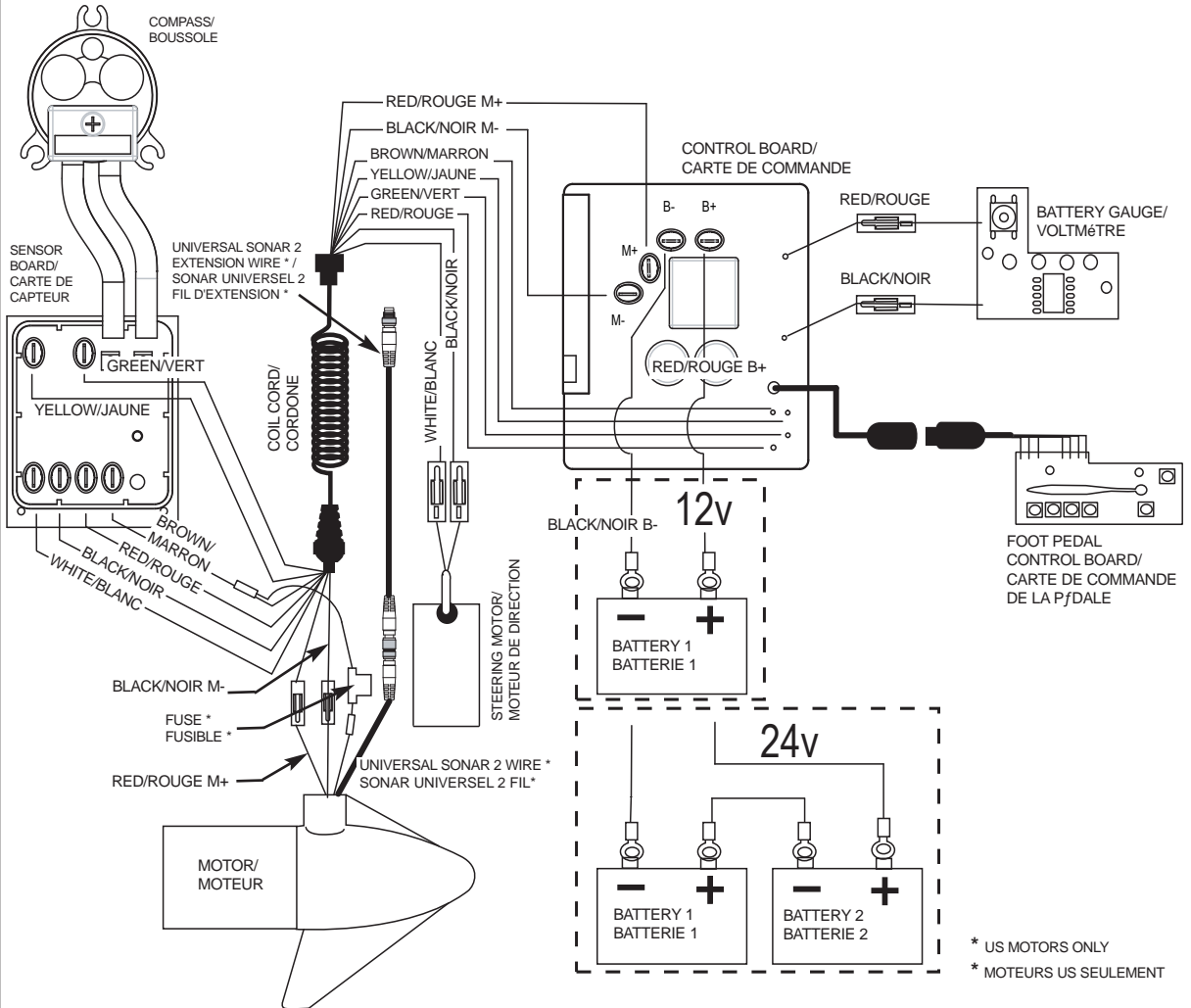

* US MOTORS ONLY
* MOTEURS US SEULEMENT

NOTE: UNIVERSAL SONAR 2 WIRES APPLICABLE TO US2 MOTORS ONLY
NOTE: LE SONAR UNIVERSEL 2 FILS APPLICABLES AUX MOTEURS US2 SEULEMENT