

**MAXXUM 101**  
101 lbs Thrust  
36 Volt 46 Amps  
42" SHAFT

for use with "L" serial numbers  
2-year warranty

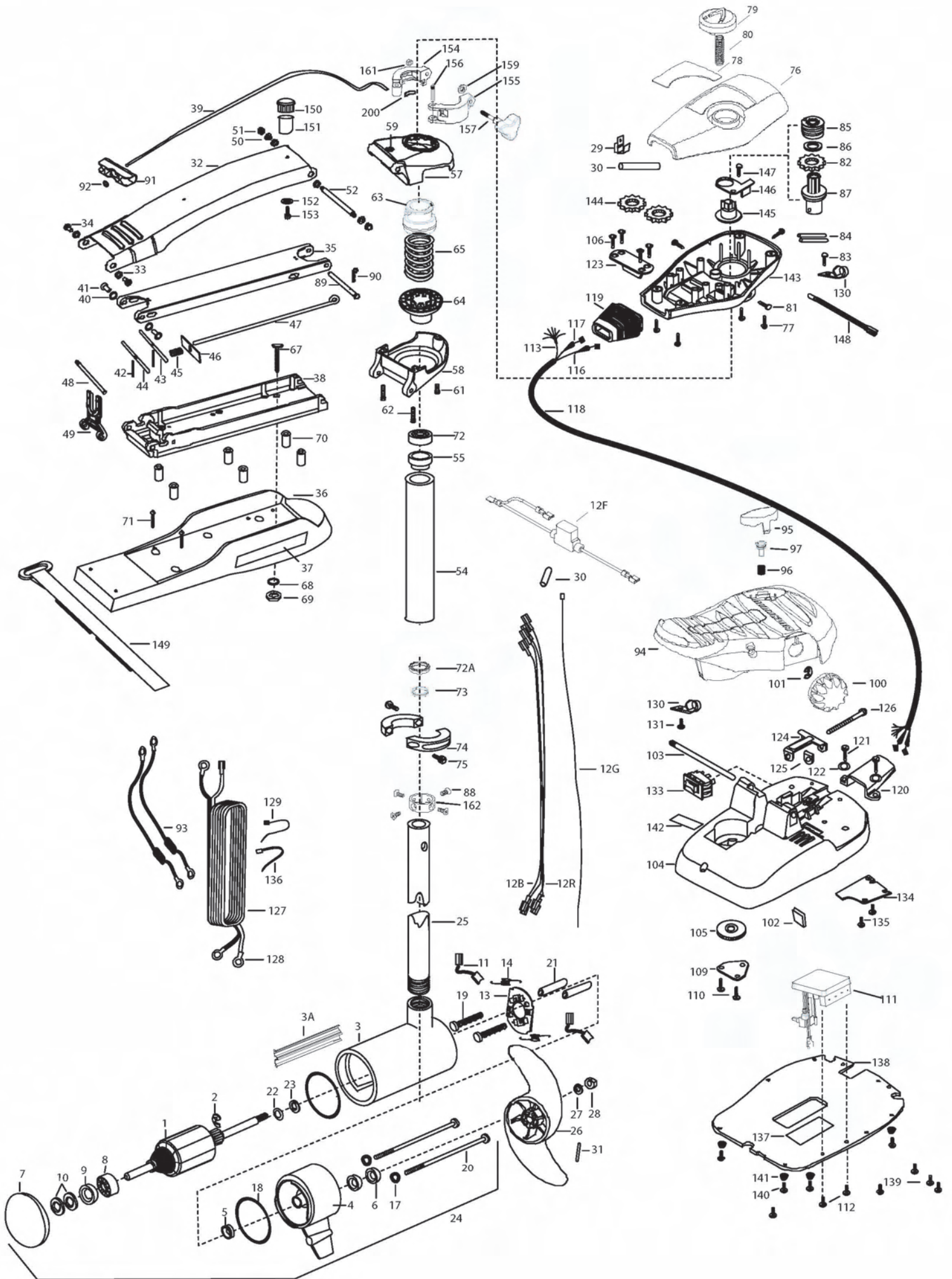

In the U.S.A., replacement parts may be ordered directly from MINN KOTA Parts Dept., 121 Power Drive, P.O.Box 8129, Mankato, Minnesota 56002-8129. In Canada, parts may be ordered from any of the Canadian Authorized Service Centers shown on the enclosed list. Be sure to provide the MODEL and SERIAL numbers of your motor when ordering parts. Please use the correct part numbers from the parts list. Payment for any parts ordered from the MINN KOTA parts department, may be by cash, personal check, Discover Card, MasterCard or VISA. To order, call 1-800-227-6433 or FAX 1-800-527-4464.

Hors de États-Unis, voir la liste ci-jointe pour le Centre de Service Agréé MINN KOTA le plus proche. Lors d'une commande, ne pas oublier de fournir le numéro de modèle et le numéro de série du moteur. Toujours mentionner le numéro de pièce exact figurant sur la liste des pièces de rechange.

1	2-100-216	ARMATURE ASSEMBLY 36V 4 VARS TXT	50	9908236	WASHER SS [2.EA]	109	2266401	COVER-PULLEY STAMPING
2	788-040	RETAINING RING	51	2223100	NUT- TENSION 5/16-18 SS [2.EA]	110	2301310	SCREW-8-18 X 1/2" SS [2.EA]
3	2-200-110	CENTER HOUSING ASSEMBLY 4.0 FW TXT 101	52	2262605	PIN- BWGRD UPPER THREADED ZP	111	2264056	CONTROL BOARD ASSY 24-36V MAX
3A	582-014	CLIP, RETAINING, US2	■	2772085	TUBE W/BEARING RACE ASSEMBLY	112	2223455	SCREW 10-32 X 1/2 [2.EA]
4	2-300-160	BRUSH END HOUSING ASSEMBLY 4.0 FW TXT	54	2272085	TUBE OUTER -21" 4 HOLES	113	2261220	WIRE HARNESS MAX 101
5	144-017	BEARING -FLANGE (SERVICE ONLY)	55	2266260	BEARING RACE- 565T	116	2267505	CABLE ASSEMBLY-RIGHT 5'
6	880-025	SEAL [2.EA]				117	2267515	CABLE ASSEMBLY-LEFT 5'
7	421-276	PLAIN END HOUSING ASSEMBLY 4.0	■	2991763	BOWGUARD ASSEMBLY-FT CT FW	118	2265430	CABLE JACKET 5'
	9421-284	PLAIN END HOUSING ASSEMBLY 4.0 US2 42"	57	2772319	BRACKET BASE TOP/EYELET	119	2265110	BOOT-CONTROL BOX
8	140-010	BALL BEARING	58	2991770	BRACKET BOTTOM/BEARING ASSEMBLY	120	2265115	BOOT-FOOT PEDAL BASE
9	990-045	THRUST SPACER	59	2772352	EYELET KIT -ROPE	121	2372100	SCREW-8-18 X 5/8",THDT [2.EA]
10	992-010	SPRING WASHER [2.EA]	61	2263423	SCREW 5/16-18 X 1" SHCS ZINC	122	2261714	WASHER-MAXXUM FT PDL [2.EA]
11	186-094	BRUSH 4" [2.EA]	62	2263425	SCREW 5/16-18 X 2-1/2" SHCS [2.EA]	123	2261901	BRACKET-CONDUIT AT/MAX
12B	640-014	BRUSH WIRE- BLACK 10 AWG 54 1/2	63	2071541	SPRING-SLEEVE UPPER	124	2263210	BRACKET-CONDUIT ADJUST
12R	640-118	BRUSH WIRE- RED 10 AWG 56 XLP	64	2071535	SPRING SLEEVE, LOWER	125	2263140	NYLOCK KEEPER
12G	640-315	GROUND WIRE42" (US MOTORS ONLY)	65	2262706	SPRING, BOWGUARD, NIK	126	2263466	SCREW-1/4-20 X 2" STL PPH
12F	2218200	FUSE HOLDER (US MOTORS ONLY)	■	2994830	BAG ASSEMBLY-MAXXUM	127	2261238	LEADWIRE MAX
13	738-004	BRUSH PLATE - 4" TERMINAL	*67	2263431	SCREW 1/4-20 X 3.5" PPH [6.EA]	128	2020700	TERMINAL RING, 3/8" [2.EA]
14	975-041	SPRING -TORSION [2.EA]	*68	2261713	WASHER-1/4" FLAT S/S [6.EA]	129	2256300	TIE WRAP-5.5" BLACK
17	701-009	O-RING -THRU BOLT [2.EA]	*69	2263103	NUT -NYLOCK JAM 1/4-20 S/S [6.EA]	130	2263201	CLAMP WIRE HARNESS MICRO [2.EA]
18	701-043	O-RING [2.EA]	70	2261505	SPACER, MOTOR REST [6.EA]	131	2332103	SCREW-6-20 X 3/8" THD
■	2889460	SEAL & ORING KIT	71	2263434	SCREW, 8-18 X 1" PPH [2.EA]	133	2254031	SWITCH-MOM/OFF/COM
19	830-027	SCREW -SELF TREADED 10-32 X 2" [2.EA]	72	2266000	BEARING, BALL-STEEL	134	2266412	SWITCH PLATE, FT PEDAL
20	830-096	THRU BOLT 12-24 X 11.56" SS [2.EA]	72A	2266116	BEARING, CARTRIDGE	135	2332103	SCREW-6-20 X 3/8" THD [2.EA]
21	973-025	SPACER -BRUSH PLATE [2.EA]	73	2266001	BEARING, SPLIT RING	136	2256301	TIE WRAP-5.5" WHITE [2.EA]
22	990-051	WASHER-THRUST, STEEL	74	2261619	COLLAR HALF-ZINC-2 PER	137	2365107	INSULATING PAD 2.3 X 3.2"
23	990-052	WASHER- NYLATRON	75	2263452	SCREW- 1/4-20X3/4 SHCP SS [2.EA]	138	2264511	BOTTOM PLATE, MAX 101
24	2316280	MOTOR ASSEMBLY 36V 4 VARS TXT	76	2280201	CONTROL BOX COVER	139	2372100	SCREW-8 X 5/8" SS [5.EA]
	2326285	MOTOR ASEMBLY 36V 4 VARS. TXT US2	77	2372100	SCREW-8-18 X 5/8" THD SS [4.EA]	140	2263455	SCREW #12-14 X 1/2" THR FRM [4.EA]
25	2032003	TUBE (COMP) 4 HOLE 42"	78	2275606	DECAL COVER, MAXXUM 101	141	2265126	BUMPER PAD, FOOT PEDAL [4.EA]
■	1378132	PROPELLER KIT	79	2990140	DIRECTIONAL INDICATOR	142	2266610	DECAL-ON/OFF SWITCH
26	2331160	PROPELLER (W.WEDGE 2)	80	2282730	SPRING-INDICATOR	143	2282500	CONTROL BOX
27	2091701	WASHER-PROP (LARGE) MAX 101	81	2053414	SCREW-8-32 X 1/2" TRI-LOBE [3.EA]	144	2267800	GEAR-INDICATOR [2.EA]
28	2093101	NUT-PROP (LARGE) MAX 101	82	2267800	GEAR INDICATOR	145	2262221	INDICATOR-DRIVE
29	2020713	TERMINAL- ADAPTOR MAX50/S	83	2372100	SCREW-8-18 X 5/8" SS	146	2261905	BRACKET/INDICATOR
30	2335400	SHRINK TUBE 1/4ODX2" [2EA.]	84	2355410	SHRINK TUBE-3/8 OD X 2" [2.EA]	147	2301310	SCREW-8-18 X 1/2" SS
31	2262658	PROP PIN	85	2232360	PULLEY-CABLE DRUM	148	2264015	LIGHT/INDICATOR
■	2991840	MOUNT, BOW ASSY, W/O BGRD FW STD MAX	86	2261730	WASHER-NYLON A/T	149	2263802	STRAP- HOLD DOWN 30.5 VELCRO]
32	2264241	ARM-UPPER FW STD	87	2996247	TOP BEARING RACE /PINION DRIVE ASSEMBLY	■	2994841	BAG ASSEMBLY- MAXXUM STABILIZER
33	2293501	BUSHING, STAINLESS STEEL [4.EA]	88	2223468	SCREW-8-32 X 7/16" ZINC PLATE [4.EA]	*150	2268400	SHAFT- SUPPORT
34	2263500	BOLT, SHOULDER [2.EA]	89	2262607	PIN- CLEVIS ZN PL	*151	2268401	BUMPER- SHAFT
35	2994307	ARM-LOWER ASSEMBLY, STD, FW EXT	90	2260805	SPRING CLIP ZN PL	*152	2263465	SCREW 1/4-10X1" HHD Z/P
36	2263912	MOTOR REST STD, MAXXUM	91	2150400	PULL-GRIP	*153	2261716	WASHER- CONICAL ID.28 SS
37	2265514	DECAL- MOTOR REST [2.EA]	92	2151700	WASHER-EYE SHAFT .562"	■	2991550	CLAMP COLLAR ASSEMBLY
38	2773987	BOWPLATE/INSERT- STD FW	93	2998200	CIRCUIT BREAKER ASSEMBLY 36V-101 [2.EA]	154	2071550	CLAMP COLLAR "A"
39	2251601	ROPE 40" MAXXUM	94	2994496	FOOT PEDAL/PLUG ASSEMBLY	155	2071555	CLAMP COLLAR "B"
40	2267318	BEARING NYLINER [2.EA]	95	2993705	PUSH-BUTTON MAGNET ASSEMBLY	156	2072621	PIN-KNURLED
41	2261708	WASHER-3/8 X 1/2 X.010" SS [2.EA]	96	2302732	SPRING-LOWER PEDAL SS	157	2281505	KNOB-CLAMP COLLAR
42	2152610	SPRING-PIN (LOCKBAR) [2.EA]	97	2260810	CLIP, REED SWITCH	159	2071718	WASHER #10 NYLON RETAINING
43	2233600	LOCK BAR- (BOW MOUNT)	100	2280115	KNOB-SPEED CONTROL	161	2073102	NUT - HEX 1/4 - 28 SS
44	2233602	LOCK BAR, REAR - ZINC	101	2263000	E-RING TRU-ARC#5133-43	162	2071560	SPLIT COLLAR
45	2152700	SPRING -LOCKBAR	102	2266413	TENSION SCREW PLATE FT	163	2211410	EXTENSION CABLE US2
46	2262703	SPRING STOP	103	2260511	PIN-PIVOT A/T FT PDL	200	2075120	URETHANE PAD
47	2153602	EYE SHAFT -2LOCKBAR STD PLTD	104	2992102	FOOT PEDAL BASE/PIN ASSEMBLY			
48	2260506	HINGE-PIN HEADLESS ZINC	105	2262301	PULLEY FOOT PEDAL			
49	2293811	YOKE, MAXXUM MOUNT POLYPROPYLENE	106	2223430	SCREW- #8 X3/4" PPH TYPE 25 SS [4.EA]			

\* This item is part of an assembly. This item cannot be sold separately due to machining and /or assembly that is required.

Maxxum 101 is 36-volt only!

OPTIONAL BROWN WIRE \*  
SEE BOAT WIRING DIAGRAM  
FIL MARRON OPTIONNEL \*  
ÉQUIPÉS DE SONAR. VOYEZ LE SCHÉMA DE CÂBLAGE DU BATEAU.

