

**MAXXUM 70**  
**70 lbs Thrust**  
**24 Volt 42 Amps**  
**42" SHAFT**

for use with "L" serial numbers  
2-year warranty

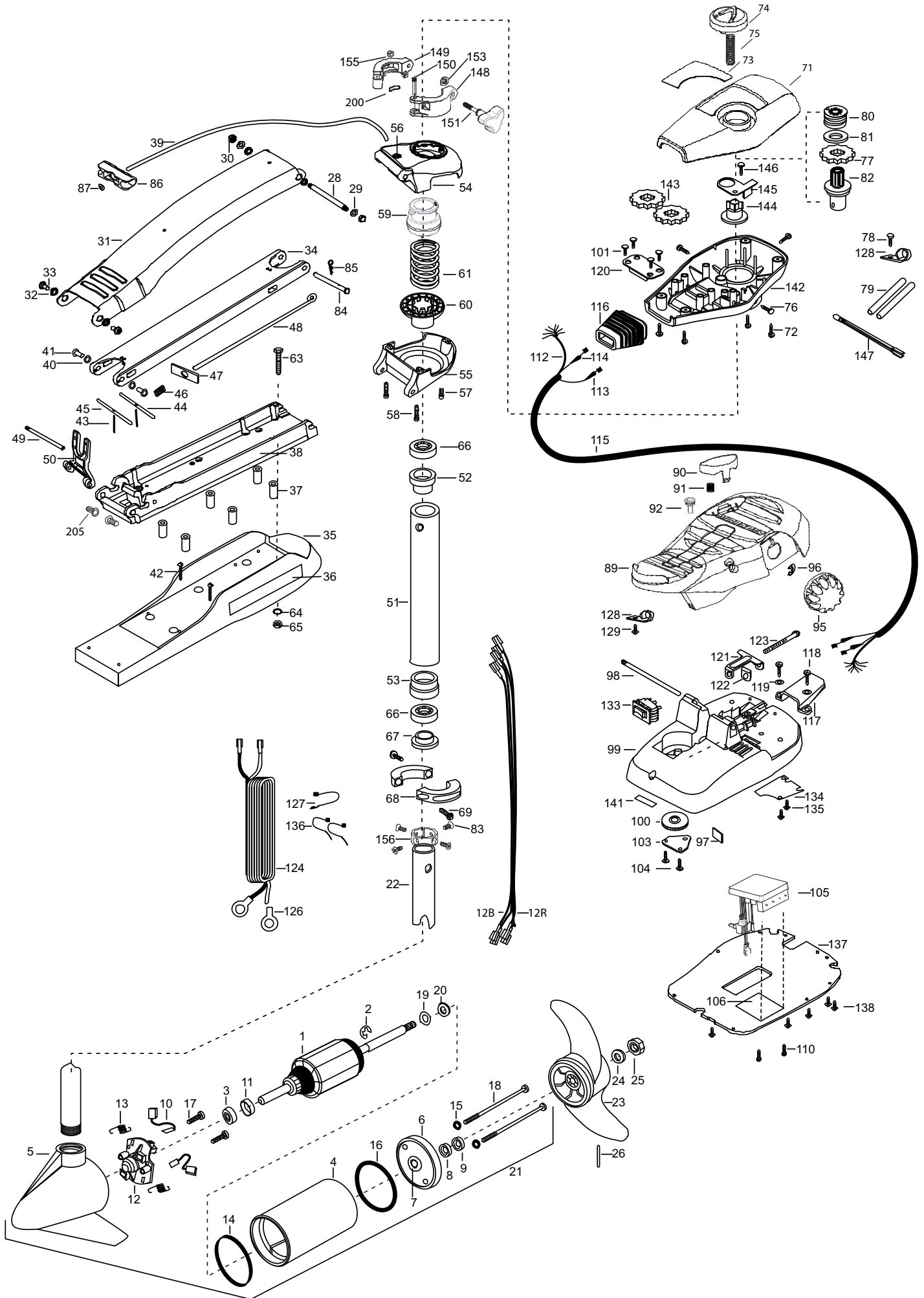

1	2-100-119	ARMATURE ASSEMBLY	■	2772012	TUBE W/BEARING RACE ASSEMBLY	112	2261220	WIRE HARNESS AT & MAX
2	788-015	RETAINING RING	51	2272069	TUBE OUTER-21" 4 HOLES	113	2267505	CABLE ASSEMBLY- RIGHT (5')
3	140-010	BALL BEARING	52	2266260	BEARING RACE	114	2267515	CABLE ASSEMBLY- LEFT (5')
4	431-005	CENTER HOUSING ASSEMBLY	53	2266220	BEARING RACE- STEEL	115	2265430	CABLE JACKET (5')
5	421-065	HOUSING BRUSH END 3.62	■	2991762	BOWGUARD ASSEMBLY- FT CTRL,FW	116	2265110	BOOT- CONTROL BOX
6	2-400-101	PLAIN END HOUSING ASSEMBLY	54	2772319	BRACKET BASE TOP/EYELET ASSEMBLY	117	2265115	BOOT- FOOT PEDAL BASE
7	144-049	BEARING - FLANGE (SERVICE CENTER ONLY)	*55	2991771	BRKT BOTTOM/BEARING FW ASSEMBLY	118	2372100	SCREW- 8-18X5/8 THD [2.EA]
8	880-003	SEAL	56	2772352	EYELET- KIT	119	2261714	WASHER- MAXXUM FT PDL [2.EA]
9	880-006	SEAL WITH SHIELD	57	2263423	SCREW 5/16-18 X 1" SHCS ZINC	120	2261901	BRACKET- CONDUIT
10	188-037	BRUSH ASSEMBLY [2.EA]	58	2263425	SCREW 5/16-18 X 2 1/2" SHCS [2.EA]	121	2263210	BRACKET- CONDUIT ADJUST
11	725-050	BRUSH RETENTION- PAPER TUBE	59	2071541	SPRING SLEEVE- UPPER	122	2263104	NYLOCK KEEPER
12	738-036	BRUSH PLATE W/HOLDER	60	2071535	SPRING SLEEVE- LOWER	123	2263463	SCREW- 1/4-20X2" STL PPH
12B	640-004	LEADWIRE BLACK 10 GA	61	2262712	SPRING- BOWGUARD, NIK PL	124	2261233	LEADWIRE- A/T VARIABLE
12R	640-105	LEADWIRE RED 10 GA	■	2994830	BAG ASSEMBLY- MAXXUM	124A	2060310	FUSED GROUND WIRE
13	975-040	SPRING - TORSION [2.EA]	*63	2263431	SCREW- 1/4-20 X 3.5 PPH [6.EA]	126	2020700	TERMINAL RING- 3/8" [2.EA]
14	337-036	GASKET	*64	2261713	WASHER- 1/4 FLAT S/S [6.EA]	127	2256300	TIE WRAP- 5.5' BLACK
15	701-008	O-RING, THRU-BOLT [2.EA]	*65	2263103	NUT- 1/4-20 NYLOCK-JAM SS [6.EA]	128	2263201	CLAMP WIRE HARNESS MICRO [2.EA]
16	701-081	O-RING	66	2266000	BEARING BALL- STEEL [2.EA]	129	2332103	SCREW- 6-20X3/8 THD (SS)
17	830-007	SCREW-8-32 [2.EA]	*67	2266115	BEARING CONE	133	2254031	SWITCH- MOM/OFF/CON
18	830-008	THRU-BOLT 10-32X9.2 [2.EA]	*68	2261619	COLLAR HALF- ZINC [2.EA]	134	2266412	SWITCH PLATE- FT PEDAL
19	990-067	WASHER- STEEL THRUST	*69	2263452	SCREW- 1/4-20X3/4 [2.EA]	135	2332103	SCREW- 6-20X3/8 THD SS [2.EA]
20	990-070	WASHER- NYLATRON	71	2280201	CONTROL BOX COVER	136	2256301	TIE WRAP- 5.5" WHITE [2.EA]
21	2096030	MOTOR ASSEMBLY 24V F/W	72	2372100	SCREW- 8-18 X 5/8 THD [4.EA]	137	2774511	BOTTOM PLATE- MAXXUM FT
22	2032003	TUBE- COMPOSITE W/4 HOLE 42"	73	2275604	DECAL- COVER MAX70/FC	138	9953104	SCREW-8 X 1/2" (SS) [5.EA]
■	1378131	PROPELLER KIT	74	2990140	DIRECTIONAL INDICATOR	139	2263455	SCREW- #12-14X1/2 THR FRM [4.EA]
23	2091160	PROPELLER W.WEDGE 2	75	2282730	SPRING - INDICATOR	140	2265126	BUMPER PAD- FOOT PEDAL [4.EA]
24	2151726	WASHER-5/16 SS	76	2053414	SCREW- 8-32 X 1/2 TRI-LOBE [3. EA]	141	2266610	DECAL- ON/OFF SWITCH
25	2053101	NUT-PROP NYLOC	77	2267800	GEAR- INDICATOR	142	2282500	CONTROL BOX- PLASTIC
26	2092600	PIN-DRIVE	78	2372100	SCREW- 8-18 X 5/8	143	2267800	GEAR- INDICATOR [2.EA]
28	2262605	PIN- BWGRD UPPER THREADED ZP	79	2355410	SHRINK TUBE- 3/8 OD X 2" [3.EA]	144	2262221	INDICATOR- DRIVE
29	9908236	WASHER- 1/4 FLAT ZINC [2.EA]	80	2232360	PULLEY- CABLE DRUM	145	2261905	BRACKET/INDICATOR
30	2223100	NUT- TENSION 5/16-18 SS [2.EA]	81	2261730	WASHER- NYLON A/T CON	146	2301310	SCREW- 8-18X1/2"
■	2991840	MOUNT- ASSEMBLY, W/O BG, STD FW MAX	82	2996247	TOP BEARING RACE /PINION DRIVE	147	2264015	LIGHT/INDI0CATOR
31	2264241	ARM-UPPER STD FW	83	2223468	SCREW- 8-32 X 7/16 [4.EA]	148	2211410	EXTENSION CABLE- SONAR
32	2293501	BUSHING- STAINLESS STEEL [4.EA]	84	2262607	PIN- CLEVIS ZP MAXXUM BWGRD	■	2991550	CLAMP COLLAR ASSEMBLY
33	2263500	BOLT- SHOULDER MAXXUM [2.EA]	85	2260805	CLIP- SPRING ZP MAX BG	149	2071550	CLAMP COLLAR "A"
34	2774315	ARM-LOWER ASSEMBLY,STD,FW,EXTRA [INCLUDES 39, 43-47, 86,87]	86	2150400	PULL- GRIP	150	2071555	CLAMP COLLAR "B"
			87	2151700	WASHER- EYE SHAFT(.562 OD)	151	2072621	PIN-KNURLED
35	2263912	MOTOR REST (STD) FW	89	2994496	FOOT PEDAL/PLUG ASSEMBLY	152	2281505	KNOB-CLAMP COLLAR
36	2265514	DECAL- MAXXUM MOTOR REST [2.EA]	90	2993705	PUSH- BUTTON MAGNET ASSY	154	2071718	WASHER #10 NYLON RETAINING
37	2261505	SPACER- MOTOR REST [6.EA]	91	2302732	SPRING- LOWER PEDAL	155	2071716	WASHER - FLAT SS
38	2773987	BOWPLATE- W/INSERT	92	2260810	CLIP, REED SWITCH	157	2071560	SPLIT COLLAR
39	2251601	ROPE (40"), MAXXUM MOUNT	95	2280115	KNOB- SPEED CONTROL (VAR)	158	2263804	STRAP - VELCRO 30.5"
40	2261708	WASHER- 3/8X1/2X.010 SS [2.EA]	96	2263000	E-RING THU-ARC	200	2075120	URETHANE PAD
41	2267318	BEARING NYLINER [2.EA]	97	2266413	TENSION SCREW PLATE FTPEDAL	205	2261540	INSERT-THREADED BOWPLATE (2 EA)
42	2263434	SCREW, 8-18X1" PPH [2.EA]	*98	2260511	PIN- PIVOT A/T FT PDL			
43	2152610	SPRING- PIN LOCKBAR [2.EA]	99	2774550	FT PEDAL BASE/PIN ASSEMBLY			
44	2233600	LOCK BAR- BOW MOUNT	100	2262301	PULLEY- FOOT PEDAL			
45	2233602	LOCK BAR REAR - ZINC	101	2223430	SCREW- #8X3/4 PPH TYPE 25 SS [4.EA]			
46	2152700	SPRING- LOCKBAR CAD.PLTD	103	2266400	COVER- PULLEY			
47	2262703	SPRING STOP- MAXXUM	104	2301310	SCREW- 8-18 X 1/2 [4.EA]			
48	2153602	EYE SHAFT-2LOCKBAR STD	105	2264056	CNTR0L BOARD ASSEMBLY 24-36V MAX			
49	2260506	HINGE-PIN HEADLESS ZINC	106	2365107	INSULATING PAD (2.3X3.2)			
50	2293811	YOKE- MAKXUM MOUNT,POLYPROPYLENE	110	2223455	SCREW- 10-32 X 1/2" [2.EA]			

\* This item is part of an assembly. This item cannot be sold separately due to machining and /or assembly that is required.

# Maxxum 70 is 24-volt only!

OPTIONAL BROWN WIRE \*  
SEE BOAT WIRING DIAGRAM  
FIL MARRON OPTIONNEL \*  
ÉQUIPÉS DE SONAR. VOYEZ LE SCHÉMA DE CÂBLAGE DU BATEAU.

