

PONTOON 70 / HC
70 lbs Thrust
24 Volt 42 Amps
52" Shaft

for use with "L" serial numbers
2-year warranty

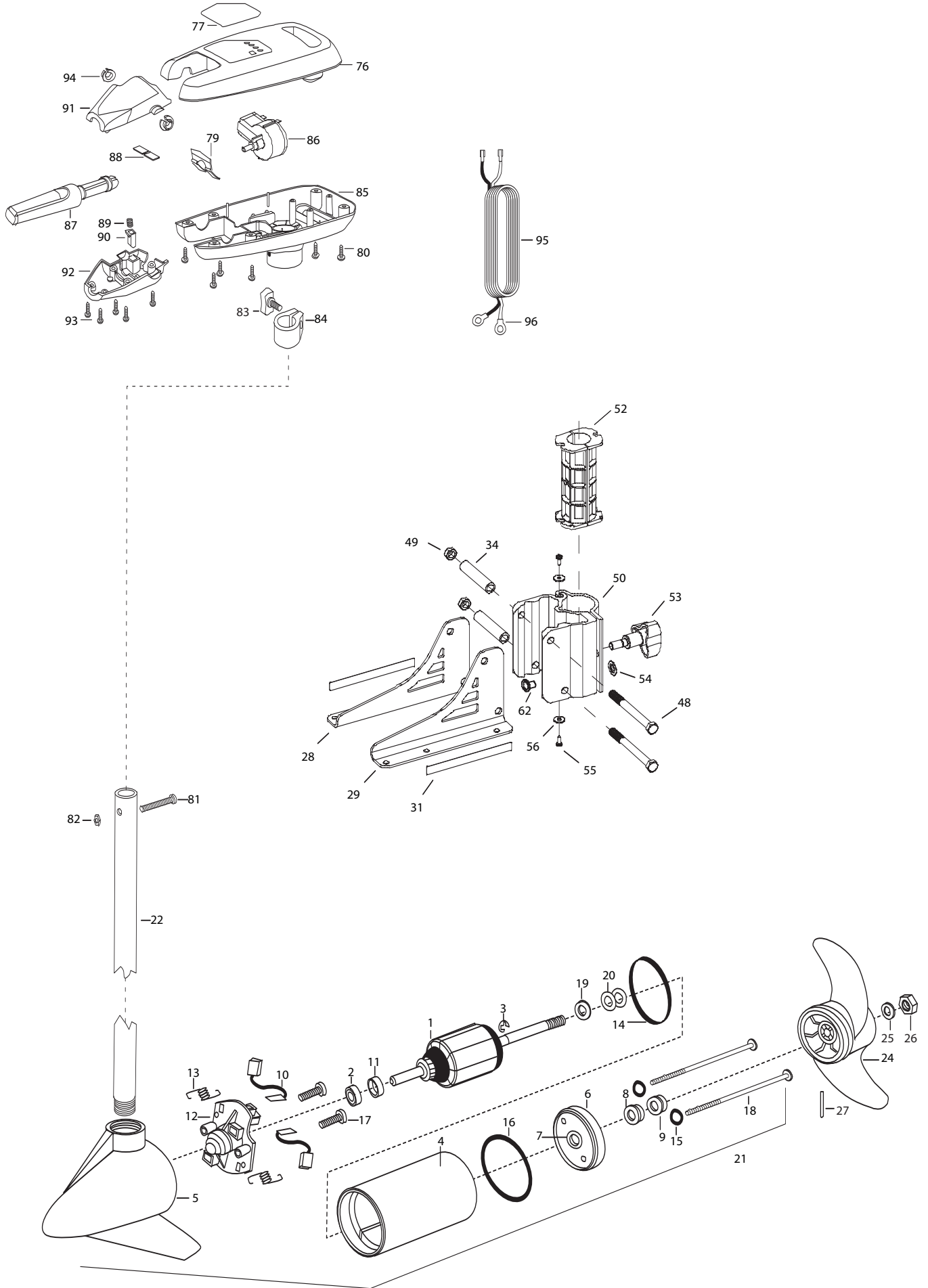

In the U.S.A., replacement parts may be ordered directly from MINN KOTA Parts Dept., 121 Power Drive, Mankato, Minnesota 56001. In Canada, parts may be ordered from any of the Canadian Authorized Service Centers shown on the enclosed list. Be sure to provide the MODEL and SERIAL numbers of your motor when ordering parts. Please use the correct part numbers from the parts list. Payment for any parts ordered from the MINN KOTA parts department, may be by cash, personal check, Discover Card, MasterCard or VISA. To order, call 1-800-227-6433 or FAX 1-800-527-4464.

1	2-100-119	ARMATURE ASSEMBLY 24V 3.625	50	2991829	HINGE-DOOR-KNOB ASSEMBLY
2	140-010	BEARING-BALL	52	2261537	HINGE-DOOR SLEEVE [2 EA.]
3	788-015	RETAINING RING	53	2260905	KNOB-SOFT GRIP, L&D
4	2-200-005	CENTER HOUSING ASSEMBLY	54	2261728	WASHER-RETAINING 3/8"
5	2-300-139	BRUSH END HOUSING ASSEMBLY SPDCO	55	2053415	SCREW #8-32 X 3/8" TRI [2 EA.]
6	2-400-101	PLAIN END HOUSING ASSEMBLY	56	2261732	WASHER #8, NYLON [2 EA.]
7	144-049	BEARING- FLANGE SERVICE ONLY	62	2264703	INSERT-THREADED
8	880-003	SEAL	76	2060285	COVER-CONTROL BOX
9	880-006	SEAL-W/SHIELD	77	2265678	DECAL-COVER EDGE 70/H
10	188-037	BRUSH ASSEMBLY [2.EA]	79	2302743	SPRING-DETENT HANDLE-TILT
11	725-035	TUBE- BRUSH RETENTION	80	2303412	SCREW-6-20 X 5/8 SELF TAP [6.EA]
12	738-036	BRUSH PLATE WITH HOLDER	81	2033400	SCREW-10-24 X 1-3/4]
13	975-040	SPRING- TORSION [2.EA]	82	2013110	NUT-10-24 HEX (ZCP)
14	337-036	GASKET	83	2011365	SCREW-COLLAR/NEW KNOB
15	701-008	O-RING THRU BOLT [2.EA]	84	2031520	COLLAR-DEPTH W/O INSERT
16	701-081	O-RING	85	2062551	CONTROL BOX PLAS W/HAND
17	830-007	#8-32 SCREW [2.EA]	86	2064028	SWITCH-FWD/REV 5SP
18	830-008	THRU BOLT 10-32X8.83 [2.EA]	87	2990912	HANDLE ASSEMBLY-W/U-JOINT 5SP
19	990-067	WASHER- STEEL THRUST	88	2302742	SPRING-DETENT OFF
20	990-070	WASHER-NYLATRON [2.EA]	89	2302745	SPRING-RELEASE BUTTON
21	2096039	MOTOR ASSEMBLY 24V F/W 3.625 5SPCO	90	2303720	RELEASE BUTTON-HANDLE
22	2032068	TUBE- COMPOSITE-52"	91	2060408	HANDLE- TOP HALF
■	1378131	PROPELLER KIT	92	2060415	HANDLE- LOWER HALF
*24	2091160	PROPELLER- W/WEDGE 2	93	2303412	SCREW-6-20 X 5/8 SELF TAP [5.EA]
*25	2151726	WASHER- 5/16 SS	94	2060005	BEARING-HANDLE PIVOT [2.EA]
*26	2053101	NUT-PROP NYLOC	95	2090650	LEADWIRE -10 GA RINGS
*27	2092600	PIN-DRIVE	96	2020700	TERMINAL RING, 3/8' [2.EA]
■	2991715	PONTOON BRACKET ASSEMBLY	■	2994838	BAG ASSEMBLY-BOLTS NUTS WASHERS
28	2261915	BRACKET, LEFT	*98	2263462	SCREW 1/4-20X2 SS [6.EA]
29	2261916	BRACKET, RIGHT	*99	2261713	WASHER-1/4 FLAT 18-18 [6.EA]
31	2265689	DECAL, MINNKOTA [2 EA.]	*100	2263103	NUT- 1/4-20 NYLOC-JAM [6.EA]
34	2261727	BRACKET SPACER [2 EA.]			
48	2263511	BOLT 3/8-16 X 4.0" [2 EA.]	■	2888460	SEAL & ORING KIT
49	2263114	NUT-NYLOCK JAM 3/8-16 [2 EA.]			

* This item is part of an assembly. This item cannot be sold separately due to machining and /or assembly that is required.

12-24 VOLT 5 SPEED MODELS MODÈLES 12-24 V INTERRUPTEUR

THIS IS A UNIVERSAL MULTI-VOLTAGE DIAGRAM. DOUBLE CHECK YOUR MOTORS VOLTAGE FOR PROPER CONNECTIONS
CECI EST UN SCHÉMA À TENSION MULTIPLE UNIVERSEL. REVÉRIFIEZ LA TENSION DE VOTRE MOTEUR POUR BIEN LE BRANCHER.

Pontoon 70 is 24-volt only!

