

68 PD PONTOON
68 LBS THRUST
24 VOLT 42 AMPS
48" SHAFT

for use with "L" serial numbers
2-year warranty

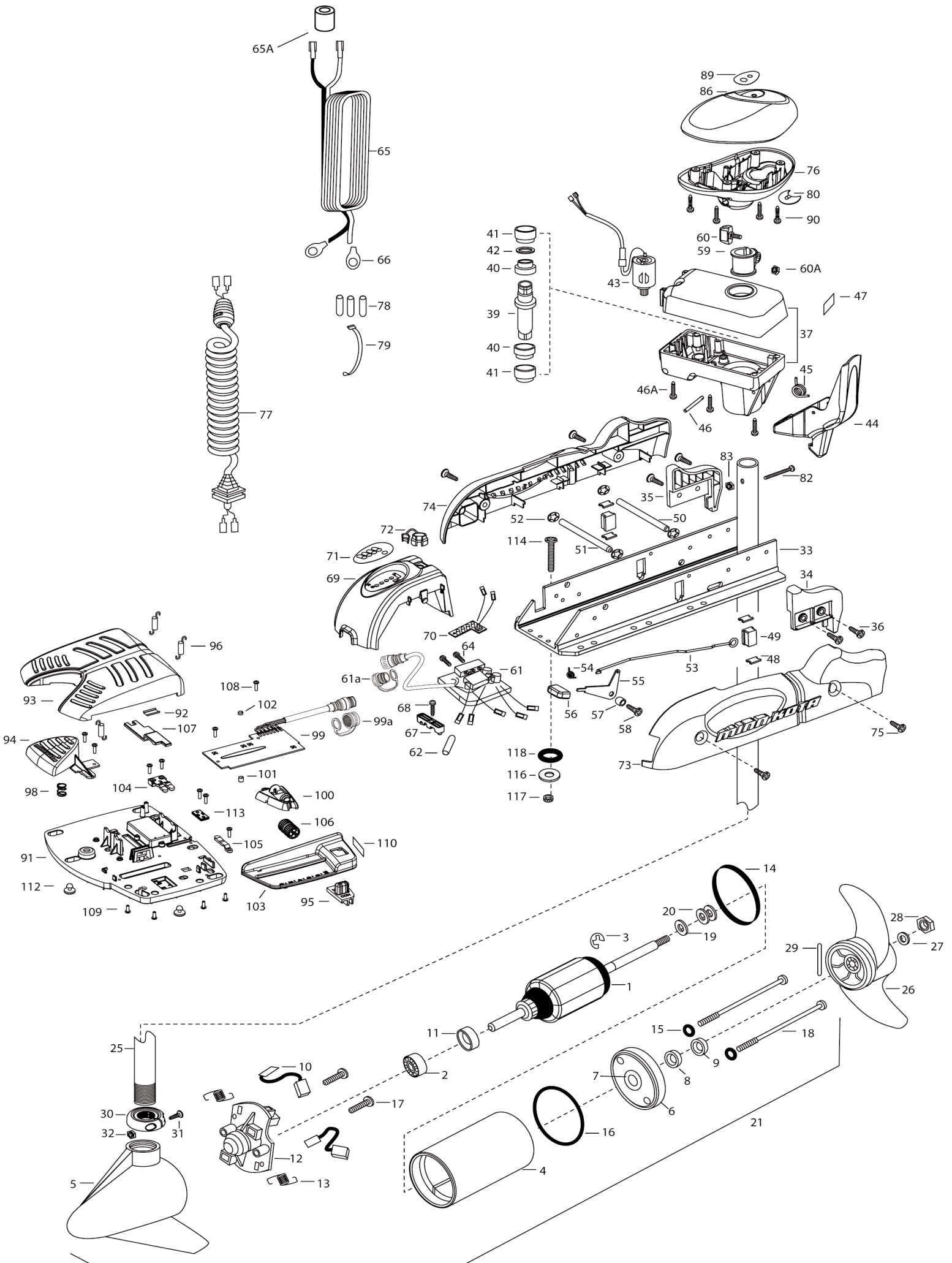

In the U.S.A., replacement parts may be ordered directly from MINN KOTA Parts Dept., 121 Power Drive, P.O. Box 8129, Mankato, Minnesota 56002-8129. In Canada, parts may be ordered from any of the Canadian Authorized Service Centers shown on the enclosed list. Be sure to provide the MODEL and SERIAL numbers of your motor when ordering parts. Please use the correct part numbers from the parts list. Payment for any parts ordered from the MINN KOTA parts department, may be by cash, personal check, Discover Card, MasterCard or VISA. To order, call 1-800-227-6433 or FAX 1-800-527-4464.

Hors de États-Unis, voir la liste ci-jointe pour le Centre de Service Agréé MINN KOTA le plus proche. Lors d'une commande, ne pas oublier de fournir le numéro de modèle et le numéro de série du moteur. Toujours mentionner le numéro de pièce exact figurant sur la liste des pièces de rechange.

1	2-100-119	ARMATURE ASSEMBLY 24V VARS TXT	*42	2304603	O-RING	78	2065400	WIRE INSULATOR-LGE 1-3/4 [3.EA]
2	140-010	BALL BEARING	43	2307050	MOTOR- DRIVE HOUSING HIGH SPD	79	2256300	TIE WRAP-5" BLACK
3	788-015	RETAINING RING	44	2307201	LATCH HANDLE PD/AP	80	2224702	INSERT- PLUG
4	2-200-005	HOUSING ASSEMBLY CENTER 3.62 TXT	45	2302750	SPRING- LATCH TORSION PD/AP			
5	421-065	HOUSING -BRUSH END 3.62 TXT	46	2302627	PIN- ROLL ZINC	82	2033400	SCREW-10-24 X 1-3/4 PPH Z/P
6	2-400-101	PLAIN END HOUSING ASSEMBLY 3.625	46A	2303407	SCREW - DRIVE HOUSING [6 EA]	83	2013110	NUT-HEX 10-24 ZCP
7	144-049	BEARING - FLANGE (SERVICE ONLY)	47	2305564	DECAL-STOW/DEPLOY	86	2300237	CONTROL BOX COVER- POWERDRIVE
8	880-003	SEAL	48	2305110	PAD-PIVOT SUPT [4.EA]	89	2315686	DECAL- COVER 68PD
9	880-006	SEAL WITH SHIELD	49	2305103	PIVOT PAD- NEW MTR'L [2.EA]	90	2012100	SCREW-8-18 X 5/8 THD CUT [4.EA]
10	188-037	BRUSH ASSEMBLY [2.EA]	50	2300500	PIN-LATCH	■	2994725	FOOT PEDAL ASSEMBLY
11	725-050	BRUSH RETENTION- PAPER TUBE	51	2300510	PIN-PIVOT	91	2304505	FOOT PEDAL BASE
12	738-036	BRUSH PLATE W/HOLDER	52	2013100	NUT-SPEED [4.EA]	92	2308501	WEAR PLATE FOOT PDL
13	975-040	SPRING - TORSION [2.EA]	53	2303612	ROD-RELEASE RT/AP S	93	2300255	FOOT PEDAL, CORDED UPPER
14	337-036	GASKET	54	2322700	SPRING-RELEASE LEVER	94	2303723	BUTTON, MOMENTARY
15	701-008	O-RING, THRU-BOLT [2.EA]	55	2303710	LEVER-RELEASE	95	2303722	BUTTON, MOM/CON
16	701-081	O-RING	56	2300101	RELEASE-KNOB	96	2302730	SPRING-LONG-UPPER PEDAL [3.EA]
17	830-007	SCREW-8-32 [2.EA]	57	2301700	SPACER-RELEASE LEVER	98	2302732	SPRING-LOWER PEDAL
18	830-042	THRU-BOLT 10-32X8.83 [2.EA]	58	2303430	SCREW-1/4-20 X 5/8	99	2304052	CONTROL BOARD ASSEMBLY-FT PDL
19	990-067	WASHER- STEEL THRUST	59	2031522	COLLAR- DRIVE (W/INSERT)	99A	2320207	DUST CAP
20	990-070	WASHER - NYLATRON [2.EA]	60	2011365	SCREW-COLLAR/NEW KNOB	100	2308620	SLIDER, SPEED
21	2096030	MOTOR ASSEMBLY 24V 3.62 48"	60A	2323404	NUT	101	2308409	MAGNET, 1/4 X 1/4
25	2032075	TUBE-CARBON COMPOSITE 48"	61	2304061	CONTROL BOARD ASSEMBLY- 24V PD	102	2778408	MAGNET, 1/4 X 1/8
■	1378131	PROPELLER KIT	61A	2320208	DUST PLUG	103	2300252	COVER, SPEED SELECTOR
26	2091160	PROPELLER W/WEDGE 2	62	2355410	SHRINK TUBE-3/8 ODX2	104	2308606	SWITCH, DOUBLE FINGER
27	2151726	WASHER-5/16 SS	64	2303434	SCREW-8-32 X 5/8 [3.EA]	105	2308608	SWITCH, SINGLE FINGER
28	2053101	NUT-PROP NYLOC	65	2090651	LEADWIRE IOGA 44"	106	2307900	WHEEL, SPEED
29	2092600	PIN-DRIVE	65A	2307310	BEAD - FERRITE (CE MODELS ONLY)	107	2308625	SLIDER, STEERING
30	2301545	COLLAR- LATCH PD/AP	66	2020700	TERMINAL RING [2.EA]	108	2302100	SCREW-6-20 X 1/2 [9.EA]
31	2303434	SCREW- 8-32X5/8 MACH PHCR	67	2321310	STRAIN RELIEF- BRACKET PD/AP	109	2372103	SCREW-6.20 X 3/8 [4.EA]
32	2303112	NUT 8-32 NYLOC SS	68	2303405	SCREW-1/4-20 X 5/8	110	2316600	DECAL, ON/OFF SWITCH
33	2301936	EXTRUSION- BASE MACHINED	69	2306555	HOUSING- CENTER PD/AP	112	2994859	BAG ASSEMBLY- 5 RUBBER BUMPERS
34	2303932	MOTOR REST- RIGHT 3-5/8	70	2074071	BATTERY GAUGE - 24 VOLT	113	2302907	STRN RLF PD FP
35	2303937	MOTOR REST- LEFT 3-5/8	71	2316605	DECAL, BATTERY GAUGE	■	2994864	BAG ASSEMBLY- (BOLT,NUT,WASHERS)
36	2303430	SCREW 1/4-20X5/8 SELF TAP [4.EA]	72	2302935	STRAIN RELIEF-DR. HOUSING	*114	2263462	BOLT-MOUNTING-1/4X2 W/STG [6.EA]
37	2771826	DRIVE HOUSING / LATCH HANDLE ASSY	73	2303943	SIDEPLATE (RIGHT)PD MK	*116	2261713	WASHER-1/4 [6.EA]
■	2882011	BUSHING/ OUTSHAFT KIT (INCLUDES 39-42)	74	2303948	SIDEPLATE(LEFT)PD MK	*117	2263103	NUT NYLOK 1/4-20 MTG [6.EA]
*39	2302010	DRIVE HOUSING OUTPUT SHAFT	75	2303430	SCREW-1/4-20 X 5/8- [4.EA]	*118	2301720	WASHER-MOUNTING RUBBER [6.EA]
*40	2307304	BUSHING- INNER [2.EA]	76	2302515	CONTROL BOX PD/AP	■	2888460	SEAL & ORING KIT
*41	2307305	BUSHING- OUTER [2.EA]	77	2991280	COIL CORD WSTRAIN RELIEF 48, 54"			
				2991282	COIL CORD WSTRAIN RELIEF 60"			

* This item is part of an assembly. This item cannot be sold separately due to machining and /or assembly that is required.

12-24 VOLT MODELS / MODÈLES 12-24 V

**THIS IS A UNIVERSAL MULTI-VOLTAGE DIAGRAM. DOUBLE CHECK YOUR MOTORS VOLTAGE FOR PROPER CONNECTIONS
CECI EST UN SCHÉMA À TENSION MULTIPLE UNIVERSEL. REVÉRIFIEZ LA TENSION DE VOTRE MOTEUR POUR BIEN LE BRANCHER.**

PowerDrive 68 is 24-volt only!

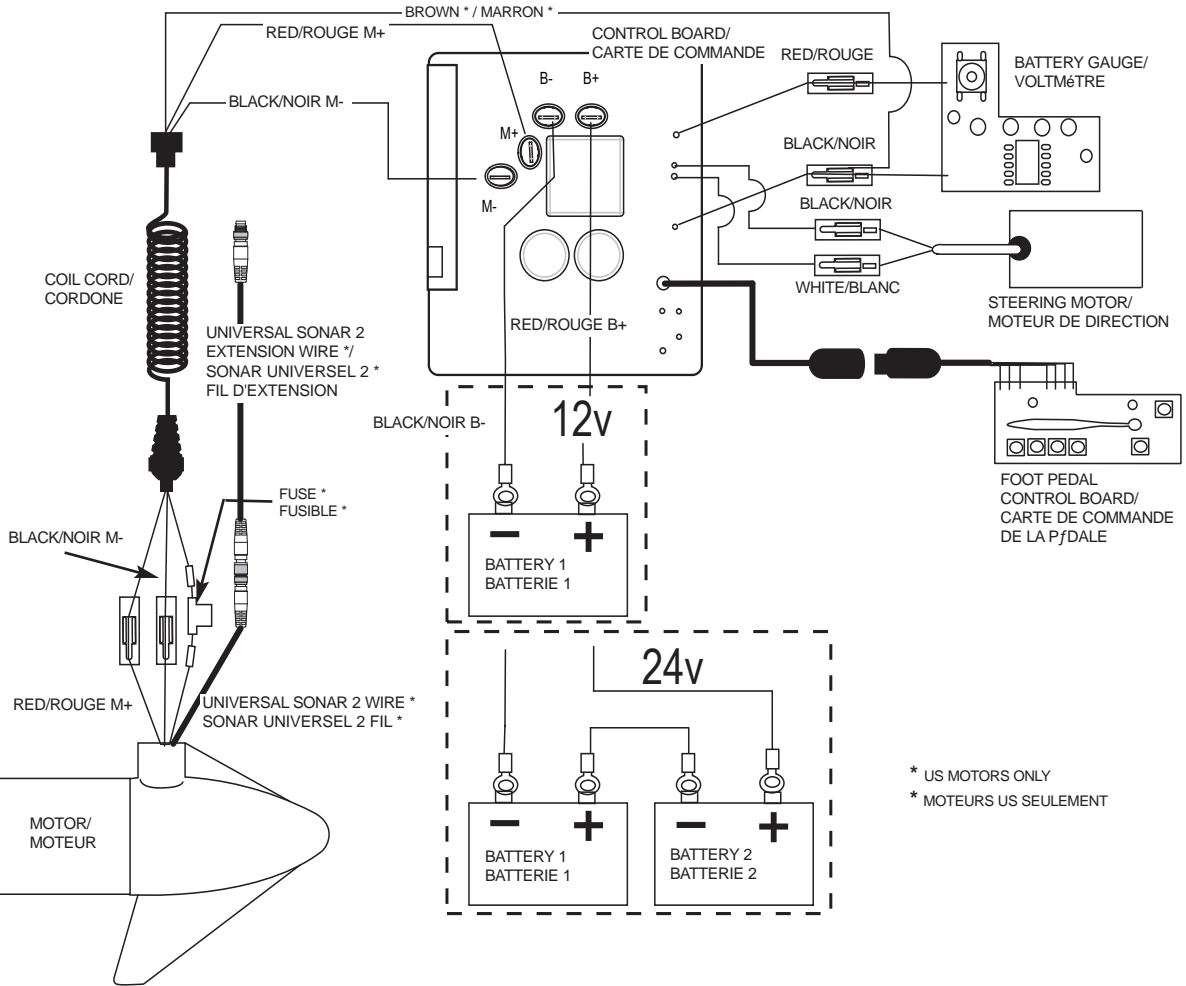

* US MOTORS ONLY
* MOTEURS US SEULEMENT

NOTE:

1. BATTERY 2 AND CONNECTING WIRE USED FOR 24V APPLICATIONS ONLY
2. UNIVERSAL SONAR 2 WIRES APPLICABLE TO US2 MOTORS ONLY

NOTEZ :

1. LA BATTERIE 2 DE CONNEXION LE FIL UTILISÉ POUR 24V LES APPLICATIONS SEULEMENT
2. LE SONAR UNIVERSEL 2 FILS APPLICABLES AUX MOTEURS US2 SEULEMENT