

55PD
55 LBS THRUST
12 VOLT 50 AMPS
54" OR 48" SHAFT

for use with "L" serial numbers
2-year warranty

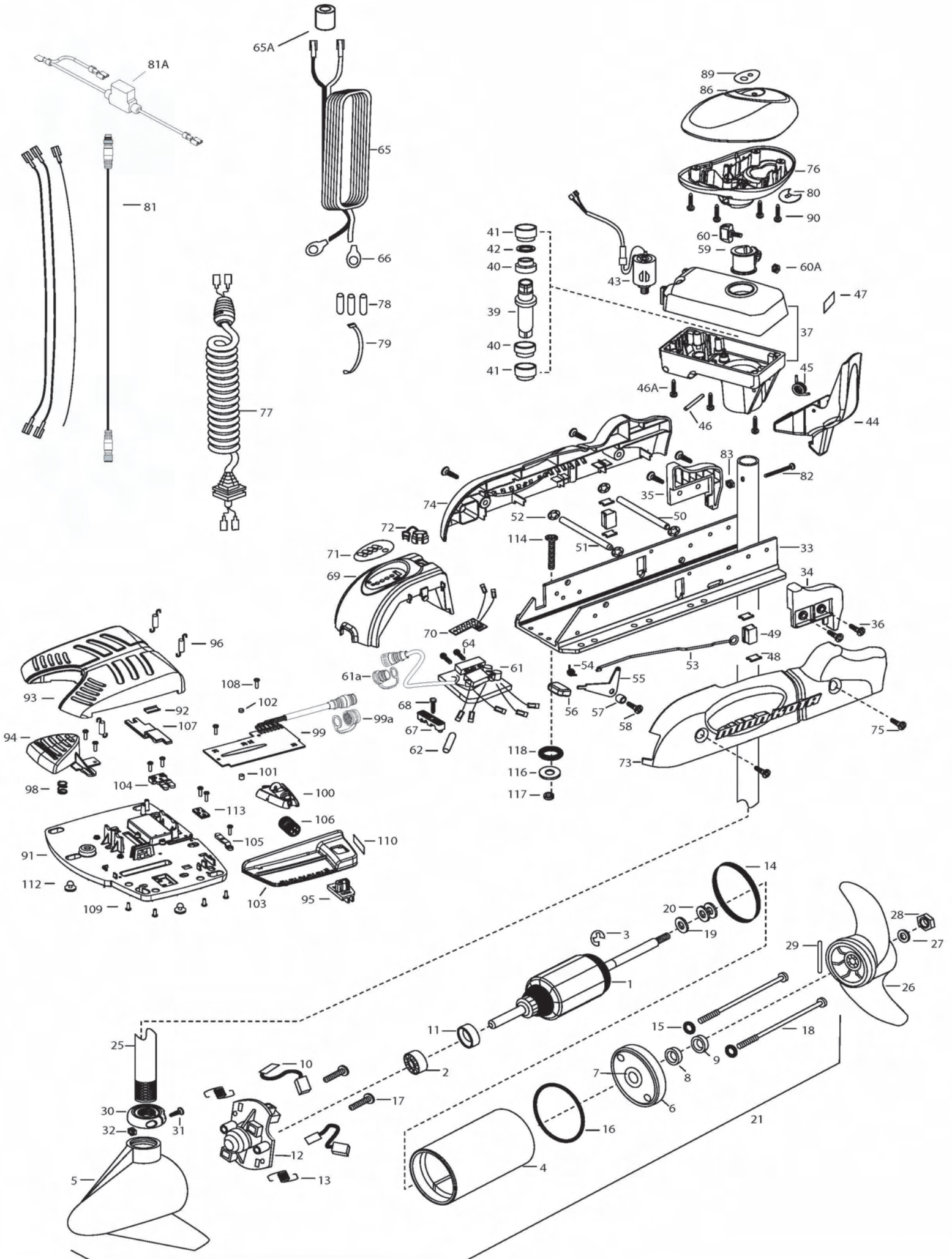

In the U.S.A., replacement parts may be ordered directly from MINN KOTA Parts Dept., 121 Power Drive, P.O. Box 8129 Mankato, Minnesota 56002-8129. In Canada, parts may be ordered from any of the Canadian Authorized Service Centers shown on the enclosed list. Be sure to provide the MODEL and SERIAL numbers of your motor when ordering parts. Please use the correct part numbers from the parts list. Payment for any parts ordered from the MINN KOTA parts department, may be by cash, personal check, Discover Card, MasterCard or VISA. To order, call 1-800-227-6433 or FAX 1-800-527-4464.

Fuera de los Estados Unidos, consultar la lista anexa para ubicar el Centro de servicio autorizado MINN KOTA. No dejar de incluir el número del MODELO y el número de SERIE del motor para el cual se solicitan las piezas. Usar siempre los números de pieza correctos indicados en la lista de piezas.

1	2-100-121	ARMATURE ASSEMBLY 12V VARS TXT	*40	2307304	BUSHING- INNER [2.EA]	78	2065400	WIRE INSULATOR-LGE 1-3/4 [3.EA]
2	140-010	BALL BEARING	*41	2307305	BUSHING- OUTER [2.EA]	79	2256300	TIE WRAP-5" BLACK
3	788-015	RETAINING RING	*42	2304603	O-RING	80	2224702	INSERT- PLUG
4	2-200-101	HOUSING ASSEMBLY CENTER 3.62 TXT	43	2307050	MOTOR- DRIVE HOUSING HIGH SPD		2224700	INSERT- PLUG US2
5	421-065	HOUSING -BRUSH END 3.62 TXT	44	2307201	LATCH HANDLE PD/AP	81	2211415	EXTENSION CABLE US2
	9421-167	HOUSING -BRUSH END 3.62 US2 48"	45	2302750	SPRING- LATCH TORSION PD/AP	81A	2218200	FUSE HOLDER, US2 MOTORS ONLY
	9421-168	HOUSING -BRUSH END 3.62 US2 54"	46	2302627	PIN- ROLL ZINC	82	2033400	SCREW-10-24 X 1-3/4 PPH Z/P
6	2-400-101	PLAIN END HOUSING ASSEMBLY 3.625	46A	2303407	SCREW - DRIVE HOUSING [6 EA]	83	2013110	NUT-HEX 10-24 ZCP
7	144-049	BEARING - FLANGE (SERVICE ONLY)	47	2305564	DECAL-STOW/DEPLOY	86	2300237	CONTROL BOX COVER- POWERDRIVE
8	880-003	SEAL	48	2305110	PAD-PIVOT SUPT [4.EA]	89	2315682	DECAL- COVER 55PD
9	880-006	SEAL WITH SHIELD	49	2305103	PIVOT PAD- NEW MTR'L [2.EA]		2315687	DECAL - COVER 55 PD / US
10	188-036	BRUSH ASSEMBLY [2.EA]	50	2300500	PIN-LATCH	90	2012100	SCREW-8-18 X 5/8 THD CUT [4.EA]
11	725-050	BRUSH RETENTION- PAPER TUBE	51	2300510	PIN-PIVOT	■	2994725	FOOT PEDAL ASSEMBLY
12	738-036	BRUSH PLATE W/HOLDER	52	2013100	NUT-SPEED [4.EA]	91	2304505	FOOT PEDAL BASE
13	975-040	SPRING - TORSION [2.EA]	53	2303612	ROD-RELEASE RT/AP S	92	2308501	WEAR PLATE FOOT PDL
14	337-036	GASKET	54	2322700	SPRING-RELEASE LEVER	93	2300255	FOOT PEDAL, CORDED UPPER
15	701-008	O-RING, THRU-BOLT [2.EA]	55	2303710	LEVER-RELEASE	94	2303723	BUTTON, MOMENTARY
16	701-081	O-RING	56	2300101	RELEASE-KNOB	95	2303722	BUTTON, MOM/CON
17	830-007	SCREW-8-32 [2.EA]	57	2301700	SPACER-RELEASE LEVER	96	2302730	SPRING-LONG-UPPER PEDAL [3.EA]
18	830-042	THRU-BOLT 10-32X8.83 [2.EA]	58	2303430	SCREW-1/4-20 X 5/8	98	2302732	SPRING-LOWER PEDAL
19	990-067	WASHER- STEEL THRUST	59	2031522	COLLAR- DRIVE (W/INSERT)	99	2304052	CONTROL BOARD ASSEMBLY-FT PDL
20	990-070	WASHER - NYLATRON [2.EA]	60	2011365	SCREW-COLLAR/NEW KNOB	99A	2320207	DUST CAP
21	2097090	MOTOR ASSEMBLY 12V 3.62 54"	60A	2323104	NUT	100	2308620	SLIDER, SPEED
	2107098	MOTOR ASSEMBLY US2 12V 3.62 VARS 54"	61	2304060	CONTROL BOARD ASSEMBLY- 12V PD	101	2308409	MAGNET, 1/4 X 1/4
25	2032076	TUBE-CARBON COMPOSITE 54"	61A	2320208	DUST PLUG	102	2778408	MAGNET, 1/4 X 1/8
	2032075	TUBE-CARBON COMPOSITE 48"	62	2355410	SHRINK TUBE-3/8 ODX2	103	2300252	COVER, SPEED SELECTOR
■	1378131	PROPELLER KIT	64	2303434	SCREW-8-32 X 5/8 [3.EA]	104	2308606	SWITCH, DOUBLE FINGER
26	2091160	PROPELLER W/WEDGE 2	65	2090651	LEADWIRE IOGA 44"	105	2308608	SWITCH, SINGLE FINGER
27	2151726	WASHER-5/16 SS	65A	2307310	BEAD - FERRITE (CE MODELS ONLY)	106	2307900	WHEEL, SPEED
28	2053101	NUT-PROP NYLOC	66	2020700	TERMINAL RING [2.EA]	107	2308625	SLIDER, STEERING
29	2092600	PIN-DRIVE	67	2321310	STRAIN RELIEF- BRACKET PD/AP	108	2302100	SCREW-6-20 X 1/2 [9.EA]
30	2301545	COLLAR- LATCH PD/AP	68	2323405	SCREW-1/4-20 X 5/8	109	2372103	SCREW-6.20 X 3/8 [4.EA]
31	2303434	SCREW- 8-32X5/8 MACH PHCR	69	2306555	HOUSING- CENTER PD/AP	110	2316600	DECAL, ON/OFF SWITCH
32	2303112	NUT 8-32 NYLOC SS	70	2074070	BATTERY GAUGE - 12 VOLT	112	2994859	BAG ASSEMBLY- 5 RUBBER BUMPERS
33	2301936	EXTRUSION- BASE MACHINED	71	2316605	DECAL, BATTERY GAUGE	113	2302907	STRN RLF PD FP
34	2303932	MOTOR REST- RIGHT 3-5/8	72	2302935	STRAIN RELIEF-DR. HOUSING	■	2994864	BAG ASSEMBLY- (BOLT,NUT,WASHERS)
35	2303937	MOTOR REST- LEFT 3-5/8	73	2303960	SIDEPLATE (RIGHT)PD MK	*114	2263462	BOLT-MOUNTING-1/4X2 W/STG [6.EA]
36	2303430	SCREW 1/4-20X5/8 SELF TAP [4.EA]	74	2303965	SIDEPLATE(LEFT)PD MK	*116	2261713	WASHER-1/4 [6.EA]
37	2771826	DRIVE HOUSING / LATCH HANDLE ASSY	75	2303430	SCREW-1/4-20 X 5/8- [4.EA]	*117	2263103	NUT NYLOK 1/4-20 MTG [6.EA]
■	2882011	BUSHING/ OUTSHAFT KIT (INCLUDES 39-42)	76	2302515	CONTROL BOX PD/AP	*118	2301720	WASHER-MOUNTING RUBBER [6.EA]
			77	2991283	COIL CORD W/STRAIN RELIEF 48, 54"	■	2888460	SEAL & ORING KIT
*39	2302010	DRIVE HOUSING OUTPUT SHAFT						

* This item is part of an assembly. This item cannot be sold separately due to machining and /or assembly that is required.

P/N 2314948

REV. U ECN 32764

11-10

12-24 VOLT MODELS / MODÈLES 12-24 V

**THIS IS A UNIVERSAL MULTI-VOLTAGE DIAGRAM. DOUBLE CHECK YOUR MOTORS VOLTAGE FOR PROPER CONNECTIONS
CECI EST UN SCHÉMA À TENSION MULTIPLE UNIVERSEL. REVÉRIFIEZ LA TENSION DE VOTRE MOTEUR POUR BIEN LE BRANCHER.**

PowerDrive 55 is 12-volt only!

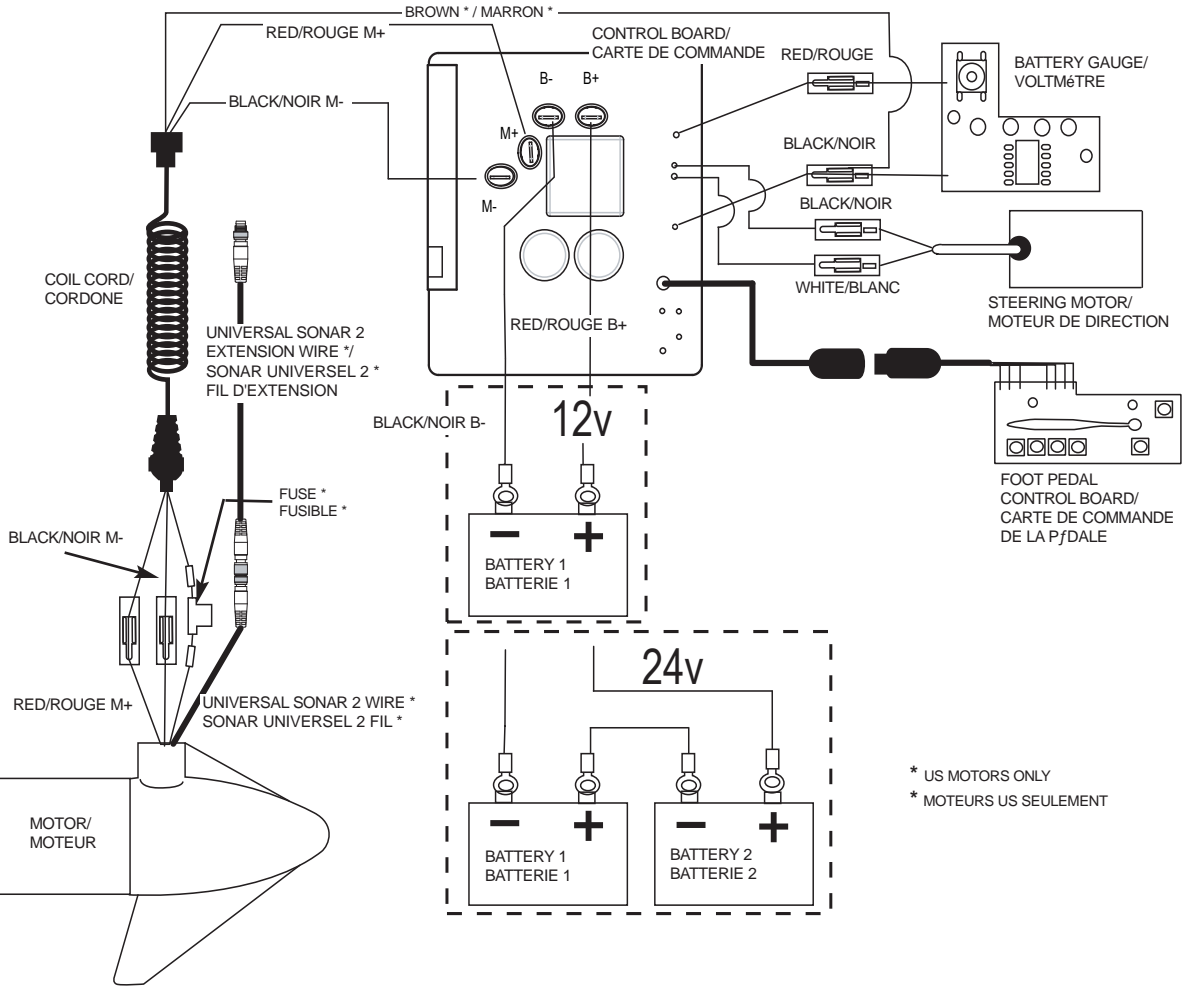

NOTE:
 1. BATTERY 2 AND CONNECTING WIRE USED FOR 24V APPLICATIONS ONLY
 2. UNIVERSAL SONAR 2 WIRES APPLICABLE TO US2 MOTORS ONLY
NOTEZ :
 1. LA BATTERIE 2 DE CONNEXION LE FIL UTILISÉ POUR 24V LES APPLICATIONS SEULEMENT
 2. LE SONAR UNIVERSEL 2 FILS APPLICABLES AUX MOTEURS US2 SEULEMENT