

70PD  
70 LBS THRUST  
24 VOLT 42 AMPS  
54" OR 60" SHAFT

for use with "L" serial numbers  
2-year warranty

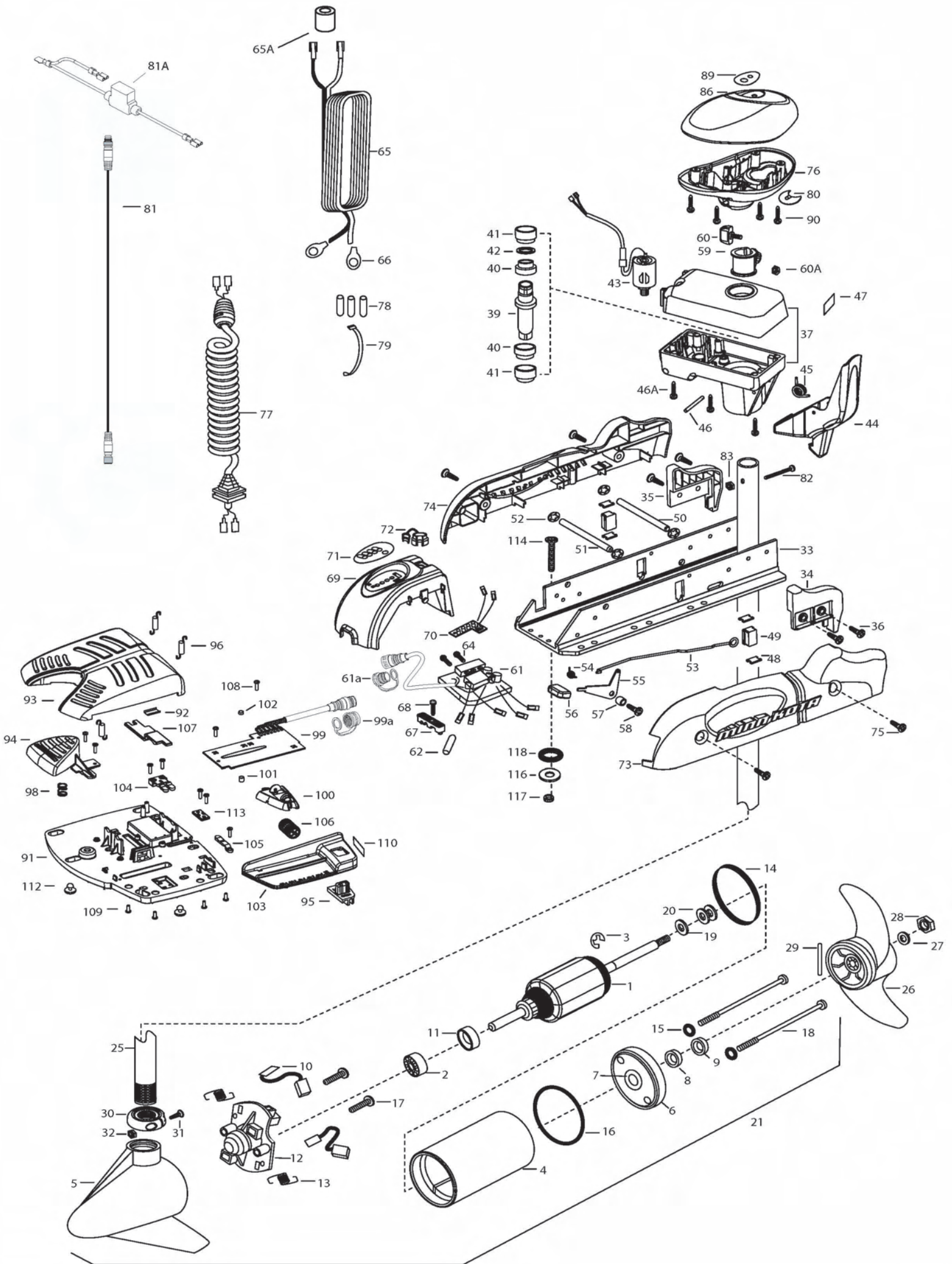

In the U.S.A., replacement parts may be ordered directly from MINN KOTA Parts Dept., 121 Power Drive, P.O. Box 8129, Mankato, Minnesota 56002-8129. In Canada, parts may be ordered from any of the Canadian Authorized Service Centers shown on the enclosed list. Be sure to provide the MODEL and SERIAL numbers of your motor when ordering parts. Please use the correct part numbers from the parts list. Payment for any parts ordered from the MINN KOTA parts department, may be by cash, personal check, Discover Card, MasterCard or VISA. To order, call 1-800-227-6433 or FAX 1-800-527-4464.

Hors de États-Unis, voir la liste ci-jointe pour le Centre de Service Agréé MINN KOTA le plus proche. Lors d'une commande, ne pas oublier de fournir le numéro de modèle et le numéro de série du moteur. Toujours mentionner le numéro de pièce exact figurant sur la liste des pièces de rechange.

1	2-100-119	ARMATURE ASSEMBLY 24V VARS TXT	*40	2307304	BUSHING- INNER [2.EA]	78	2065400	WIRE INSULATOR-LGE 1-3/4 [3.EA]
2	140-010	BALL BEARING	*41	2307305	BUSHING- OUTER [2.EA]	79	2256300	TIE WRAP-5" BLACK
3	788-015	RETAINING RING	*42	2304603	O-RING	80	2224702	INSERT- PLUG
4	2-200-005	HOUSING ASSEMBLY CENTER 3.62 TXT	43	2307050	MOTOR- DRIVE HOUSING HIGH SPD		2224700	INSERT- PLUG US2
5	421-065	HOUSING -BRUSH END 3.62 TXT	44	2307201	LATCH HANDLE PD/AP	81	2211415	UNIVERSAL SONAR II EXTENSION CABLE
	9421-168	HOUSING - BRUSH END US2	45	2302750	SPRING- LATCH TORSION PD/AP	81A	2218200	FUSE HOLDER, US2 MOTORS ONLY
6	2-400-101	PLAIN END HOUSING ASSEMBLY 3.625	46	2302627	PIN- ROLL ZINC	82	2033400	SCREW-10-24 X 1-3/4 PPH Z/P
7	144-049	BEARING - FLANGE (SERVICE ONLY)	46A	2303407	SCREW - DRIVE HOUSING [6 EA]	83	2013110	NUT-HEX 10-24 ZCP
8	880-003	SEAL	47	2305564	DECAL-STOW/DEPLOY	86	2300237	CONTROL BOX COVER- POWERDRIVE
9	880-006	SEAL WITH SHIELD	48	2305110	PAD-PIVOT SUPT [4.EA]	89	2315685	DECAL- COVER 70PD
10	188-037	BRUSH ASSEMBLY [2.EA]	49	2305103	PIVOT PAD- NEW MTR'L [2.EA]		2315688	DECAL- COVER 70PD US
11	725-050	BRUSH RETENTION- PAPER TUBE	50	2300500	PIN-LATCH	90	2012100	SCREW-8-18 X 5/8 THD CUT [4.EA]
12	738-036	BRUSH PLATE W/HOLDER	51	2300510	PIN-PIVOT	■	2994725	FOOT PEDAL ASSEMBLY
13	975-040	SPRING - TORSION [2.EA]	52	2013100	NUT-SPEED [4.EA]	91	2304505	FOOT PEDAL BASE
14	337-036	GASKET	53	2303612	ROD-RELEASE RT/AP S	92	2308501	WEAR PLATE FOOT PDL
15	701-008	O-RING, THRU-BOLT [2.EA]	54	2322700	SPRING-RELEASE LEVER	93	2300255	FOOT PEDAL, CORDED UPPER
16	701-081	O-RING	55	2303710	LEVER-RELEASE	94	2303723	BUTTON, MOMENTARY
17	830-007	SCREW-8-32 [2.EA]	56	2300101	RELEASE-KNOB	95	2303722	BUTTON, MOM/CON
18	830-042	THRU-BOLT 10-32X8.83 [2.EA]	57	2301700	SPACER-RELEASE LEVER	96	2302730	SPRING-LONG-UPPER PEDAL [3.EA]
19	990-067	WASHER- STEEL THRUST	58	2303430	SCREW-1/4-20 X 5/8	98	2302732	SPRING-LOWER PEDAL
20	990-070	WASHER - NYLATRON [2.EA]	59	2031522	COLLAR- DRIVE (W/INSERT)	99	2304052	CONTROL BOARD ASSEMBLY-FT PDL
21	2096031	MOTOR ASSEMBLY 24V 3.62 54"	60	2011365	SCREW-COLLAR/NEW KNOB	99A	2320207	DUST CAP
	2096032	MOTOR ASSEMBLY 24V 3.62 60"	60A	2323104	NUT	100	2308620	SLIDER, SPEED
	2106045	MOTOR ASSEMBLY US2 24V 3.62 54"	61	2304061	CONTROL BOARD ASSEMBLY- 24V PD	101	2308409	MAGNET, 1/4 X 1/4
	2106036	MOTOR ASSEMBLY US2 24V 3.62 60"	61A	2320208	DUST COVER	102	2778408	MAGNET, 1/4 X 1/8
25	2032076	TUBE-CARBON COMPOSITE 54"	62	2355410	SHRINK TUBE-3/8 ODX2	103	2300252	COVER, SPEED SELECTOR
	2032074	TUBE-CARBON COMPOSITE 60"	64	2303434	SCREW-8-32 X 5/8 [3.EA]	104	2308606	SWITCH, DOUBLE FINGER
■	1378131	PROPELLER KIT	65	2090651	LEADWIRE IOGA 44"	105	2308608	SWITCH, SINGLE FINGER
26	2091160	PROPELLER W/WEDGE 2	65A	2307310	BEAD - FERRITE (CE MODELS ONLY)	106	2307900	WHEEL, SPEED
27	2151726	WASHER-5/16 SS	66	2020700	TERMINAL RING [2.EA]	107	2308625	SLIDER, STEERING
28	2053101	NUT-PROP NYLOC	67	2321310	STRAIN RELIEF- BRACKET PD/AP	108	2302100	SCREW-6-20 X 1/2 [9.EA]
29	2092600	PIN-DRIVE	68	2323405	SCREW-1/4-20 X 5/8	109	2372103	SCREW-6.20 X 3/8 [4.EA]
30	2301545	COLLAR- LATCH PD/AP	69	2306555	HOUSING- CENTER PD/AP	110	2316600	DECAL, ON/OFF SWITCH
31	2303434	SCREW- 8-32X5/8 MACH PHCR	70	2074071	BATTERY GAUGE - 24 VOLT	112	2994859	BAG ASSEMBLY- 5 RUBBER BUMPERS
32	2303112	NUT 8-32 NYLOC SS	71	2316605	DECAL, BATTERY GAUGE	113	2302907	STRN RLF PD FP
33	2301936	EXTRUSION- BASE MACHINED	72	2302935	STRAIN RELIEF-DR. HOUSING	■	2994864	BAG ASSEMBLY- (BOLT,NUT,WASHERS)
34	2303932	MOTOR REST- RIGHT 3-5/8	73	2303960	SIDEPLATE (RIGHT)PD MK	*114	2263462	BOLT-MOUNTING-1/4X2 W/STG [6.EA]
35	2303937	MOTOR REST- LEFT 3-5/8	74	2303965	SIDEPLATE(LEFT)PD MK	*116	2261713	WASHER-1/4 [6.EA]
36	2303430	SCREW 1/4-20X5/8 SELF TAP [4.EA]	75	2303430	SCREW-1/4-20 X 5/8- [4.EA]	*117	2263103	NUT NYLOK 1/4-20 MTG [6.EA]
37	2771826	DRIVE HOUSING / LATCH HANDLE ASSY	76	2302515	CONTROL BOX PD/AP	*118	2301720	WASHER-MOUNTING RUBBER [6.EA]
■	2882011	BUSHING/ OUTSHAFT KIT (INCLUDES 39-42)	77	2991283	COIL CORD WSTRAIN RELIEF 48, 54"	■	2888460	SEAL & ORING KIT
*39	2302010	DRIVE HOUSING OUTPUT SHAFT		2991284	COIL CORD WSTRAIN RELIEF 60"			

\* This item is part of an assembly. This item cannot be sold separately due to machining and /or assembly that is required.

P/N 2314950

REV V ECN 32425

8-10

# 12-24 VOLT MODELS / MODÈLES 12-24 V

**THIS IS A UNIVERSAL MULTI-VOLTAGE DIAGRAM. DOUBLE CHECK YOUR MOTORS VOLTAGE FOR PROPER CONNECTIONS  
CECI EST UN SCHÉMA À TENSION MULTIPLE UNIVERSEL. REVÉRIFIEZ LA TENSION DE VOTRE MOTEUR POUR BIEN LE BRANCHER.**

**PowerDrive 70 is 24-volt only!**

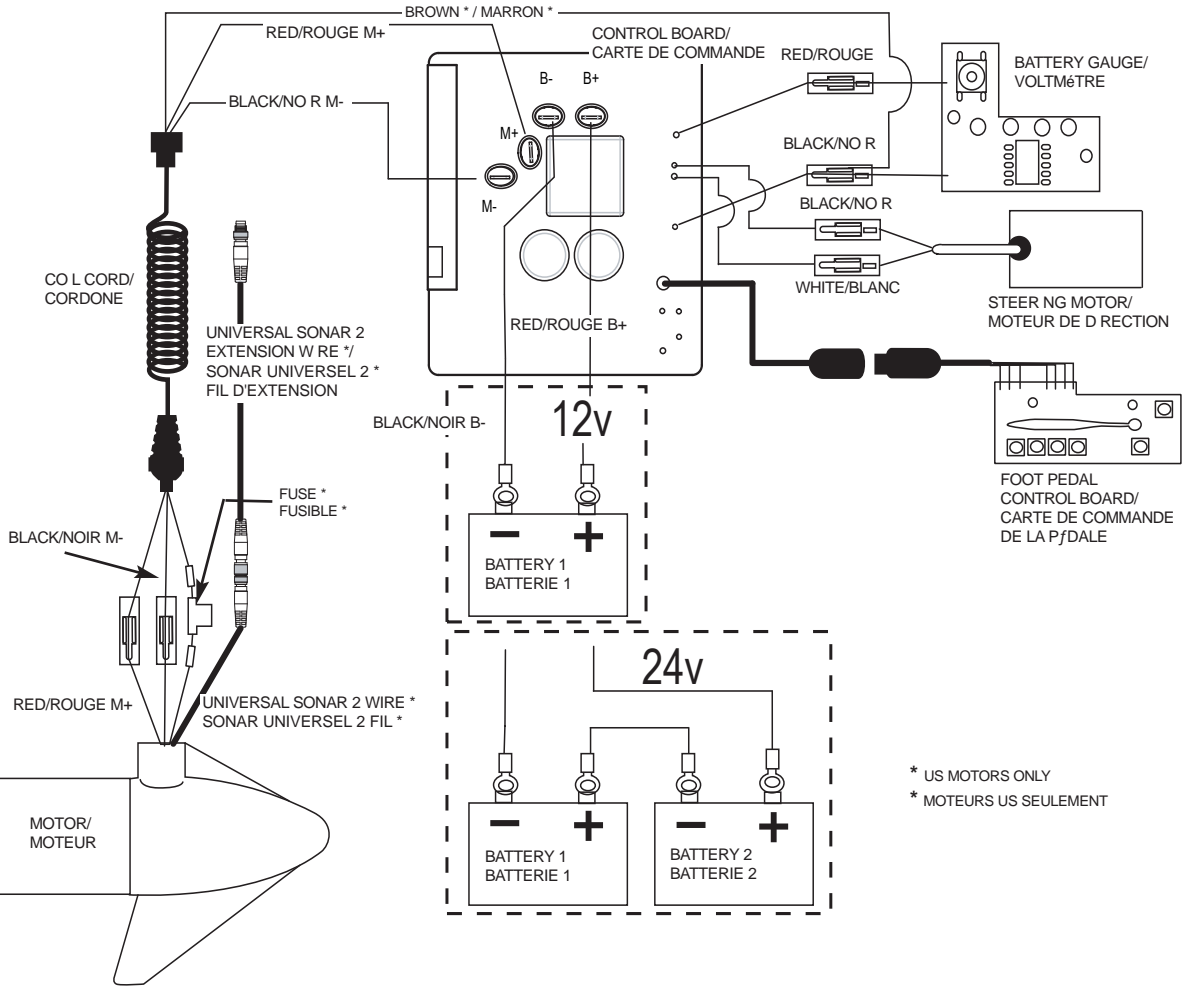

\* US MOTORS ONLY  
\* MOTEURS US SEULEMENT

**NOTE:**  
 1. BATTERY 2 AND CONNECTING WIRE USED FOR 24V APPLICATIONS ONLY  
 2. UNIVERSAL SONAR 2 WIRES APPLICABLE TO US2 MOTORS ONLY  
**NOTEZ :**  
 1. LA BATTERIE 2 DE CONNEXION LE FIL UTILISÉ POUR 24V LES APPLICATIONS SEULEMENT  
 2. LE SONAR UNIVERSEL 2 FILS APPLICABLES AUX MOTEURS US2 SEULEMENT