

80PD  
80 LBS THRUST  
24 VOLT 56 AMPS  
54" OR 60" SHAFT

for use with "L" serial numbers  
2-year warranty

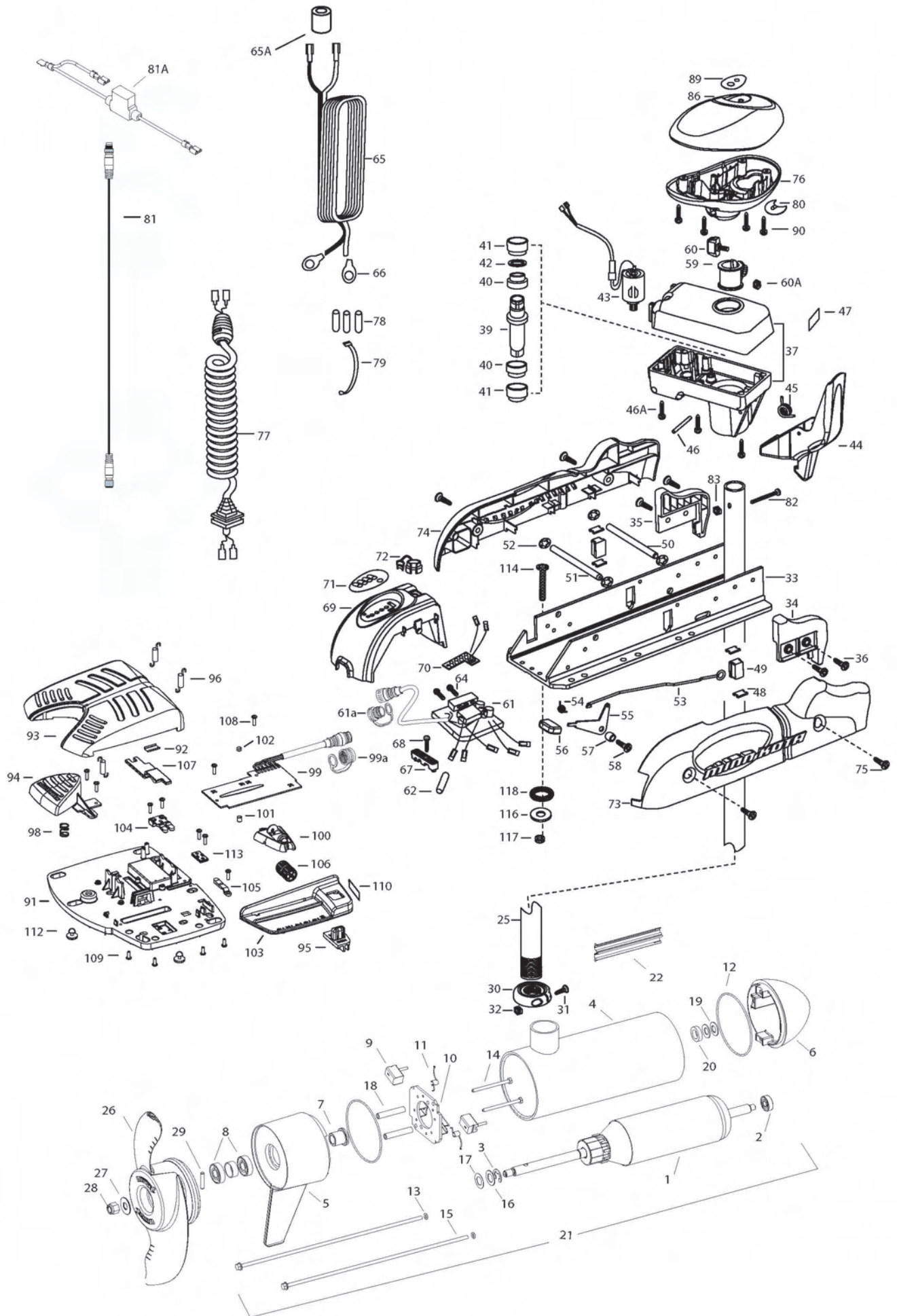

1	2-100-214	ARMATURE ASSEMBLY	*39	2302010	DRIVE HOUSING OUTPUT SHAFT	2991282	COIL CORD WSTRAIN RELIEF 60"
2	140-010	BEARING	*40	2307304	BUSHING- INNER [2.EA]	78	2065400 WIRE INSULATOR-LGE 1-3/4 [3.EA]
3	788-040	RETAINING RING	*41	2307305	BUSHING- OUTER [2.EA]	79	2256300 TIE WRAP-5" BLACK
4	2-200-160	CENTER HOUSING ASSEMBLY	*42	2304603	O-RING	80	2224702 INSERT- PLUG
5	2-300-160	BRUSH END HOUSING ASSEMBLY	43	2307050	MOTOR- DRIVE HOUSING HIGH SPD	2224700	INSERT- PLUG US2
6	421-276	PLAIN END HOUSING ASSEMBLY STD	44	2307201	LATCH HANDLE PD/AP	81	2211415 UNIVERSAL SONAR II EXTENSION CABLE
	9421-289	PLAIN END HOUSING ASSEMBLY SONAR 52"	45	2302750	SPRING- LATCH TORSION PD/AP	81A	2218200 FUSE HOLDER, US2 MOTORS ONLY
	9421-290	PLAIN END HOUSING ASSEMBLY SONAR 62"	46	2302627	PIN- ROLL ZINC	82	2033400 SCREW-10-24 X 1-3/4 PPH Z/P
7	144-017	FLANGE BEARING	46A	2303407	SCREW - DRIVE HOUSING [6 EA]	83	2013110 NUT-HEX 10-24 ZCP
8	880-025	SEAL	47	2305564	DECAL-STOW/DEPLOY	86	2300237 CONTROL BOX COVER- POWERDRIVE
9	188-094	BRUSH	48	2305110	PAD-PIVOT SUPT [4.EA]	89	2315693 DECAL- COVER 80PD
10	9-738-004	BRUSH PLATE ASSEMBLY	49	2305103	PIVOT PAD- NEW MTR'L [2.EA]	2315694	DECAL- COVER 80PD US
11	975-041	BRUSH SPRING	50	2300500	PIN-LATCH	90	2012100 SCREW-8-18 X 5/8 THD CUT [4.EA]
12	701-043	O-RING, MOTOR	51	2300510	PIN-PIVOT	■	2994725 FOOT PEDAL ASSEMBLY
13	701-009	O-RING, THRU-BOLT	52	2013100	NUT-SPEED [4.EA]	91	2304505 FOOT PEDAL BASE
14	830-027	SCREW, 10-32 X 2	53	2303612	ROD-RELEASE RT/AP S	92	2308501 WEAR PLATE FOOT PDL
15	830-094	THRU-BOLT	54	2322700	SPRING-RELEASE LEVER	93	2300255 FOOT PEDAL, CORDED UPPER
16	990-051	WASHER, STEEL	55	2303710	LEVER-RELEASE	94	2303723 BUTTON, MOMENTARY
17	990-052	WASHER, NYLATRON	56	2300101	RELEASE-KNOB	95	2303722 BUTTON, MOM/CON
18	973-025	SPACER, BRUSH PLATE	57	2301700	SPACER-RELEASE LEVER	96	2302730 SPRING-LONG-UPPER PEDAL [3.EA]
19	992-010	WASHER, BELLEVILLE[2 EA.]	58	2303430	SCREW-1/4-20 X 5/8	98	2302732 SPRING-LOWER PEDAL
20	990-045	SPACER, THRUST	59	2031522	COLLAR- DRIVE (W/INSERT)	99	2304052 CONTROL BOARD ASSEMBLY-FT PDL
■	2889460	SEAL AND O-RING KIT	60	2011365	SCREW-COLLAR/NEW KNOB	99A	2320207 DUST CAP
21	2316219	MOTOR ASSEMBLY 24V 4	60A	2323104	NUT	100	2308620 SLIDER, SPEED
	2326242	MOTOR ASSEMBLY 24V 4 US2	61	2304061	CONTROL BOARD ASSEMBLY- 24V PD	101	2308409 MAGNET, 1/4 X 1/4
22	582-013	CLIP-RETAINING SONAR	61A	2320208	DUST COVER	102	2778408 MAGNET, 1/4 X 1/8
25	2032076	TUBE-CARBON COMPOSITE 54"	62	2355410	SHRINK TUBE-3/8 ODX2	103	2300252 COVER, SPEED SELECTOR
	2032074	TUBE-CARBON COMPOSITE 60"	64	2303434	SCREW-8-32 X 5/8 [3.EA]	104	2308606 SWITCH, DOUBLE FINGER
■	1378132	PROPELLER KIT	65	2090651	LEADWIRE IOGA 44"	105	2308608 SWITCH, SINGLE FINGER
26	2331160	PROPELLER W/WEDGE 2	65A	2307310	BEAD - FERRITE (CE MODELS ONLY)	106	2307900 WHEEL, SPEED
27	2091701	WASHER-1/2 SS	66	2020700	TERMINAL RING [2.EA]	107	2308625 SLIDER, STEERING
28	2093101	NUT-PROP NYLOC	67	2321310	STRAIN RELIEF- BRACKET PD/AP	108	2302100 SCREW-6-20 X 1/2 [9.EA]
29	2262658	PIN-DRIVE	68	2323405	SCREW-1/4-20 X 5/8	109	2372103 SCREW-6.20 X 3/8 [4.EA]
30	2301545	COLLAR- LATCH PD/AP	69	2306555	HOUSING- CENTER PD/AP	110	2316600 DECAL, ON/OFF SWITCH
31	2303434	SCREW- 8-32X5/8 MACH PHCR	70	2074071	BATTERY GAUGE - 24 VOLT	112	2994859 BAG ASSEMBLY- 5 RUBBER BUMPERS
32	2303112	NUT 8-32 NYLOC SS	71	2316605	DECAL, BATTERY GAUGE	113	2302907 STRN RLF PD FP
33	2301936	EXTRUSION- BASE MACHINED	72	2302935	STRAIN RELIEF-DR. HOUSING	■	2994864 BAG ASSEMBLY- (BOLT,NUT,WASHERS)
34	2303933	MOTOR REST- RIGHT 4"	73	2303960	SIDEPLATE (RIGHT)PD MK	114	2263462 BOLT-MOUNTING-1/4X2 W/STG [6.EA]
35	2303938	MOTOR REST- LEFT 4"	74	2303965	SIDEPLATE(LEFT)PD MK	116	2261713 WASHER-1/4 [6.EA]
36	2303430	SCREW 1/4-20X5/8 SELF TAP [4.EA]	75	2303430	SCREW-1/4-20 X 5/8- [4.EA]	117	2263103 NUT NYLOK 1/4-20 MTG [6.EA]
37	2771826	DRIVE HOUSING / LATCH HANDLE ASSY	76	2302515	CONTROL BOX PD/AP	118	2301720 WASHER-MOUNTING RUBBER [6.EA]
■	2882011	BUSHING/OUTSHAFT KIT (INCLUDES 39-42)	77	2991280	COIL CORD WSTRAIN RELIEF 48, 54"	■	2889460 SEAL & ORING KIT

\* This item is part of an assembly. This item cannot be sold separately due to machining and /or assembly that is required.

# 12-24 VOLT MODELS / MODÈLES 12-24 V

**THIS IS A UNIVERSAL MULTI-VOLTAGE DIAGRAM. DOUBLE CHECK YOUR MOTORS VOLTAGE FOR PROPER CONNECTIONS  
CECI EST UN SCHÉMA À TENSION MULTIPLE UNIVERSEL. REVÉRIFIEZ LA TENSION DE VOTRE MOTEUR POUR BIEN LE BRANCHER.**

**PowerDrive 80 is 24-volt only!**

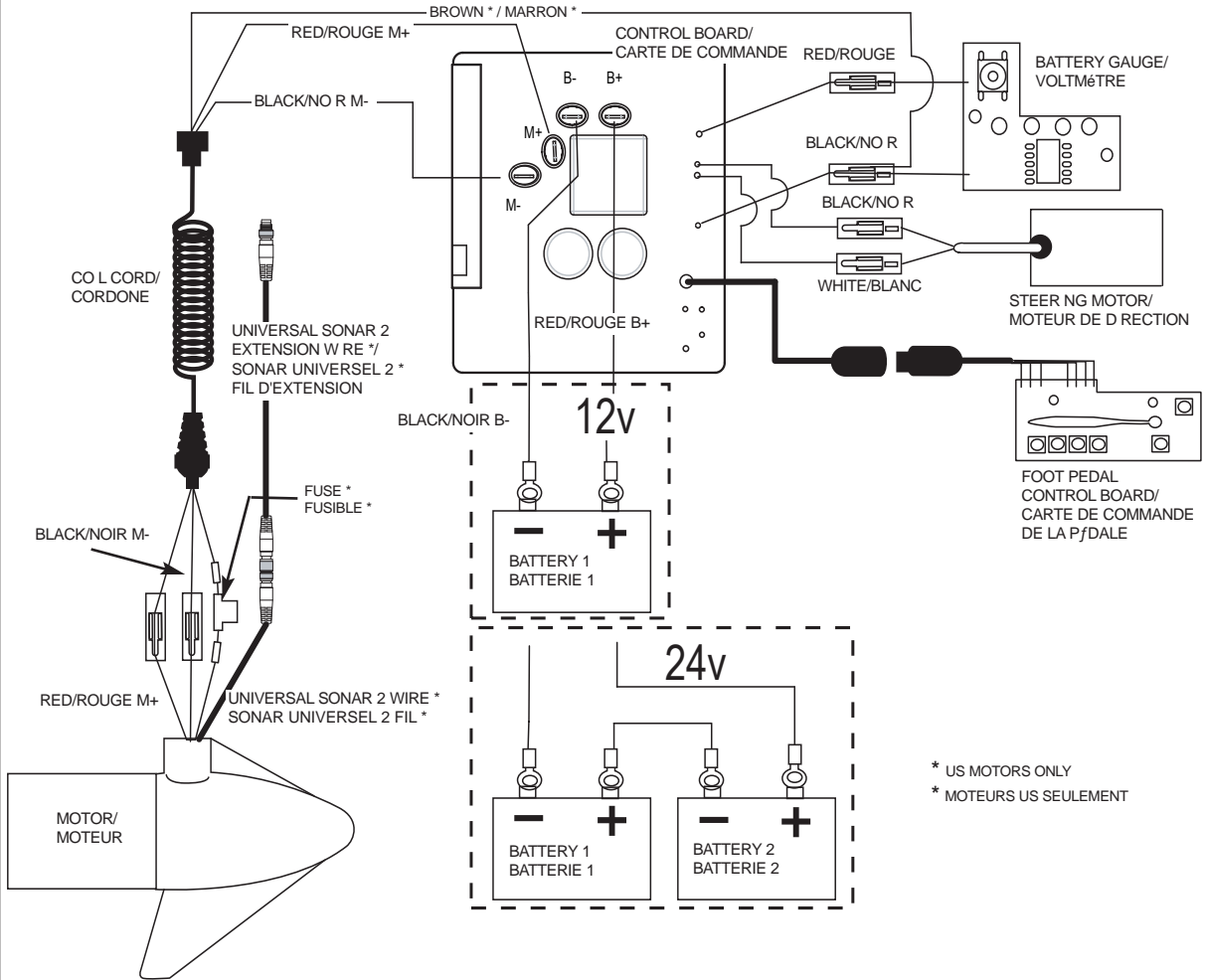

\* US MOTORS ONLY  
\* MOTEURS US SEULEMENT

**NOTE:**

1. BATTERY 2 AND CONNECTING WIRE USED FOR 24V APPLICATIONS ONLY
2. UNIVERSAL SONAR 2 WIRES APPLICABLE TO US2 MOTORS ONLY

**NOTEZ :**

1. LA BATTERIE 2 DE CONNEXION LE FIL UTILISÉ POUR 24V LES APPLICATIONS SEULEMENT
2. LE SONAR UNIVERSEL 2 FILS APPLICABLES AUX MOTEURS US2 SEULEMENT