

**MAXXUM 101**  
101 lbs Thrust  
36 Volt 46 Amps  
42" SHAFT

for use with "M" serial numbers  
2-year warranty

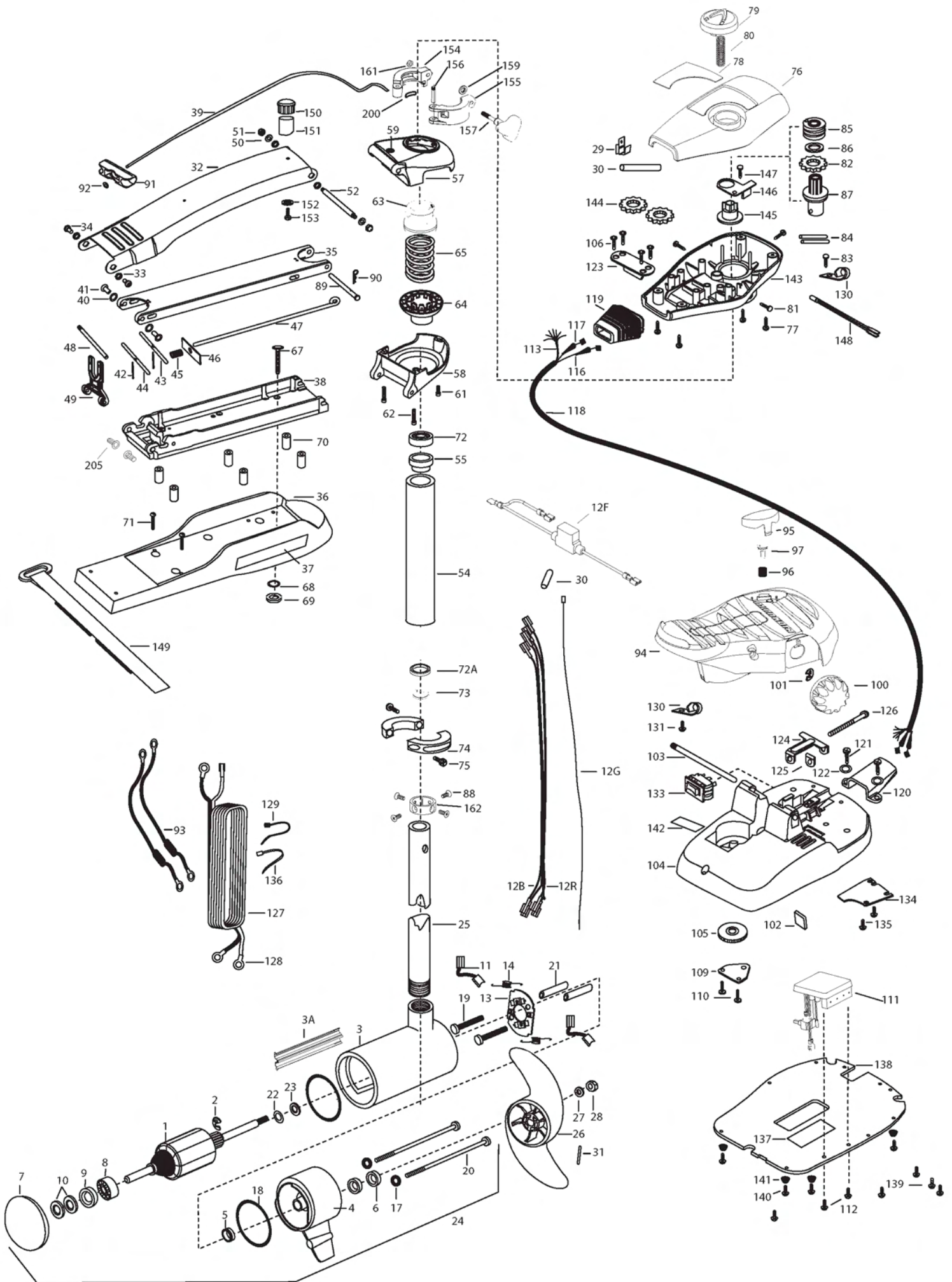

1	2-100-216	ARMATURE ASSEMBLY 36V 4 VARS TXT	50	9908236	WASHER SS [2.EA]	109	2266401	COVER-PULLEY STAMPING
2	788-040	RETAINING RING	51	2223100	NUT- TENSION 5/16-18 SS [2.EA]	110	2301310	SCREW-8-18 X 1/2" SS [2.EA]
3	2-200-110	CENTER HOUSING ASSEMBLY 4.0 FW TXT 101	52	2262605	PIN- BWGRD UPPER THREADED ZP	111	2264056	CONTROL BOARD ASSY 24-36V MAX
3A	582-014	CLIP, RETAINING, US2	■	2772085	TUBE W/BEARING RACE ASSEMBLY	112	2223455	SCREW 10-32 X 1/2 [2.EA]
4	2-300-160	BRUSH END HOUSING ASSEMBLY 4.0 FW TXT	54	2272085	TUBE OUTER -21" 4 HOLES	113	2261220	WIRE HARNESS MAX 101
5	144-017	BEARING -FLANGE (SERVICE ONLY)	55	2266260	BEARING RACE- 565T	116	2267505	CABLE ASSEMBLY-RIGHT 5'
6	880-025	SEAL [2.EA]				117	2267515	CABLE ASSEMBLY-LEFT 5'
7	421-276	PLAIN END HOUSING ASSEMBLY 4.0	■	2991763	BOWGUARD ASSEMBLY-FT CT FW	118	2265430	CABLE JACKET 5'
	9421-284	PLAIN END HOUSING ASSEMBLY 4.0 US2 42"	57	2772319	BRACKET BASE TOP/EYELET	119	2265110	BOOT-CONTROL BOX
8	140-010	BALL BEARING	58	2991770	BRACKET BOTTOM/BEARING ASSEMBLY	120	2265115	BOOT-FOOT PEDAL BASE
9	990-045	THRUST SPACER	59	2772352	EYELET KIT -ROPE	121	2372100	SCREW-8-18 X 5/8",THDT [2.EA]
10	992-010	SPRING WASHER [2.EA]	61	2263423	SCREW 5/16-18 X 1" SHCS ZINC	122	2261714	WASHER-MAXXUM FT PDL [2.EA]
11	186-094	BRUSH 4" [2.EA]	62	2263425	SCREW 5/16-18 X 2-1/2" SHCS [2.EA]	123	2261901	BRACKET-CONDUIT AT/MAX
12R	640-014	BRUSH WIRE- BLACK 10 AWG 54 1/2	63	2071541	SPRING-SLEEVE UPPER	124	2263210	BRACKET-CONDUIT ADJUST
12B	640-118	BRUSH WIRE- RED 10 AWG 56 XLP	64	2071535	SPRING SLEEVE, LOWER	125	2263140	NYLOCK KEEPER
12G	640-315	GROUND WIRE42" (US MOTORS ONLY)	65	2262706	SPRING, BOWGUARD, NIK	126	2263466	SCREW-1/4-20 X 2" STL PPH
12F	2218200	FUSE HOLDER (US MOTORS ONLY)	■	2994830	BAG ASSEMBLY-MAXXUM	127	2261238	LEADWIRE MAX
13	738-004	BRUSH PLATE - 4" TERMINAL	*67	2263431	SCREW 1/4-20 X 3.5" PPH [6.EA]	128	2020700	TERMINAL RING, 3/8" [2.EA]
14	975-041	SPRING -TORSION [2.EA]	*68	2261713	WASHER-1/4" FLAT S/S [6.EA]	129	2256300	TIE WRAP-5.5" BLACK
17	701-009	O-RING -THRU BOLT [2.EA]	*69	2263103	NUT -NYLOCK JAM 1/4-20 S/S [6.EA]	130	2263201	CLAMP WIRE HARNESS MICRO [2.EA]
18	701-043	O-RING [2.EA]	70	2261505	SPACER, MOTOR REST [6.EA]	131	2332103	SCREW-6-20 X 3/8" THD
■	2889460	SEAL & ORING KIT	71	2263434	SCREW, 8-18 X 1" PPH [2.EA]	133	2254031	SWITCH-MOM/OFF/COM
19	830-027	SCREW -SELF TREADED 10-32 X 2" [2.EA]	72	2266000	BEARING, BALL-STEEL	134	2266412	SWITCH PLATE, FT PEDAL
20	830-096	THRU BOLT 12-24 X 11.56" SS [2.EA]	72A	2266116	BEARING, CARTRIDGE	135	2332103	SCREW-6-20 X 3/8" THD [2.EA]
21	973-025	SPACER -BRUSH PLATE [2.EA]	73	2266001	BEARING, SPLIT RING	136	2256301	TIE WRAP-5.5" WHITE [2.EA]
22	990-051	WASHER-THRUST, STEEL	74	2261619	COLLAR HALF-ZINC-2 PER	137	2365107	INSULATING PAD 2.3 X 3.2"
23	990-052	WASHER- NYLATRON	75	2263452	SCREW- 1/4-20X3/4 SHCP SS [2.EA]	138	2264511	BOTTOM PLATE, MAX 101
24	2316280	MOTOR ASSEMBLY 36V 4 VARS TXT	76	2280201	CONTROL BOX COVER	139	2372100	SCREW-8 X 5/8" SS [5.EA]
	2326285	MOTOR ASEMBLY 36V 4 VARS. TXT US2	77	2372100	SCREW-8-18 X 5/8" THD SS [4.EA]	140	2263455	SCREW #12-14 X 1/2" THR FRM [4.EA]
25	2032003	TUBE (COMP) 4 HOLE 42"	78	2275606	DECAL COVER, MAXXUM 101	141	2265126	BUMPER PAD, FOOT PEDAL [4.EA]
■	1378132	PROPELLER KIT	79	2990140	DIRECTIONAL INDICATOR	142	2266610	DECAL-ON/OFF SWITCH
26	2331160	PROPELLER (W.WEDGE 2)	80	2282730	SPRING-INDICATOR	143	2282500	CONTROL BOX
27	2091701	WASHER-PROP (LARGE) MAX 101	81	2053414	SCREW-8-32 X 1/2" TRI-LOBE [3.EA]	144	2267800	GEAR-INDICATOR [2.EA]
28	2093101	NUT-PROP (LARGE) MAX 101	82	2267800	GEAR INDICATOR	145	2262221	INDICATOR-DRIVE
29	2020713	TERMINAL- ADAPTOR MAX50/S	83	2372100	SCREW-8-18 X 5/8" SS	146	2261905	BRACKET/INDICATOR
30	2335400	SHRINK TUBE 1/4ODX2" [2.EA.]	84	2355410	SHRINK TUBE-3/8 OD X 2" [2.EA]	147	2301310	SCREW-8-18 X 1/2" SS
31	2262658	PROP PIN	85	2232360	PULLEY-CABLE DRUM	148	2264015	LIGHT/INDICATOR
■	2991840	MOUNT, BOW ASSY, W/O BGRD FW STD MAX	86	2261730	WASHER-NYLON A/T	149	2263802	STRAP- HOLD DOWN 30.5 VELCRO]
32	2264241	ARM-UPPER FW STD	87	2996247	TOP BEARING RACE /PINION DRIVE ASSEMBLY	■	2994841	BAG ASSEMBLY- MAXXUM STABILIZER
33	2293501	BUSHING, STAINLESS STEEL [4.EA]	88	2223468	SCREW-8-32 X 7/16" ZINC PLATE [4.EA]	*150	2268400	SHAFT- SUPPORT
34	2263500	BOLT, SHOULDER [2.EA]	89	2262607	PIN- CLEVIS ZN PL	*151	2268401	BUMPER- SHAFT
35	2994307	ARM-LOWER ASSEMBLY, STD, FW EXT	90	2260805	SPRING CLIP ZN PL	*152	2263465	SCREW 1/4-10X1" HHD Z/P
36	2263912	MOTOR REST STD, MAXXUM	91	2150400	PULL-GRIP	*153	2261716	WASHER- CONICAL ID.28 SS
37	2265514	DECAL- MOTOR REST [2.EA]	92	2151700	WASHER-EYE SHAFT .562"	■	2991550	CLAMP COLLAR ASSEMBLY
38	2773987	BOWPLATE/INSERT- STD FW	93	2998200	CIRCUIT BREAKER ASSEMBLY 36V-101 [2.EA]	154	2071550	CLAMP COLLAR "A"
39	2251601	ROPE 40" MAXXUM	94	2994496	FOOT PEDAL/PLUG ASSEMBLY	155	2071555	CLAMP COLLAR "B"
40	2267318	BEARING NYLINER [2.EA]	95	2993705	PUSH-BUTTON MAGNET ASSEMBLY	156	2072621	PIN-KNURLED
41	2261708	WASHER-3/8 X 1/2 X.010" SS [2.EA]	96	2302732	SPRING-LOWER PEDAL SS	157	2281505	KNOB-CLAMP COLLAR
42	2152610	SPRING-PIN (LOCKBAR) [2.EA]	97	2260810	CLIP, REED SWITCH	159	2071718	WASHER #10 NYLON RETAINING
43	2233600	LOCK BAR- (BOW MOUNT)	100	2280115	KNOB-SPEED CONTROL	161	2073102	NUT - HEX 1/4 - 28 SS
44	2233602	LOCK BAR, REAR - ZINC	101	2263000	E-RING TRU-ARC#5133-43	162	2071560	SPLIT COLLAR
45	2152700	SPRING -LOCKBAR	102	2266413	TENSION SCREW PLATE FT	163	2211410	EXTENSION CABLE US2
46	2262703	SPRING STOP	103	2260511	PIN-PIVOT A/T FT PDL	200	2075120	URETHANE PAD
47	2153602	EYE SHAFT -LOCKBAR STD PLTD	104	2992102	FOOT PEDAL BASE/PIN ASSEMBLY	205	2261540	INSERT-THREADED BOWPLATE (2 EA)
48	2260506	HINGE-PIN HEADLESS ZINC	105	2262301	PULLEY FOOT PEDAL			
49	2293811	YOKE, MAXXUM MOUNT POLYPROPYLENE	106	2223430	SCREW- #8 X3/4" PPH TYPE 25 SS [4.EA]			

\* This item is part of an assembly. This item cannot be sold separately due to machining and /or assembly that is required.

THIS IS A UNIVERSAL MULTI-VOLTAGE DIAGRAM. DOUBLE CHECK YOUR MOTORS VOLTAGE FOR PROPER CONNECTIONS  
 CECI EST UN SCHÉMA À TENSION MULTIPLE UNIVERSEL. REVÉRIFIEZ LA TENSION DE VOTRE MOTEUR POUR BIEN LE BRANCHER.

Maxxum 101 is 36-volts only!

OPTIONAL BROWN WIRE \*  
 SEE BOAT WIRING DIAGRAM  
 FIL MARRON OPTIONNEL \*  
 ÉQUIPÉS DE SONAR. VOYEZ LE SCHÉMA DE CÂBLAGE DU BATEAU.

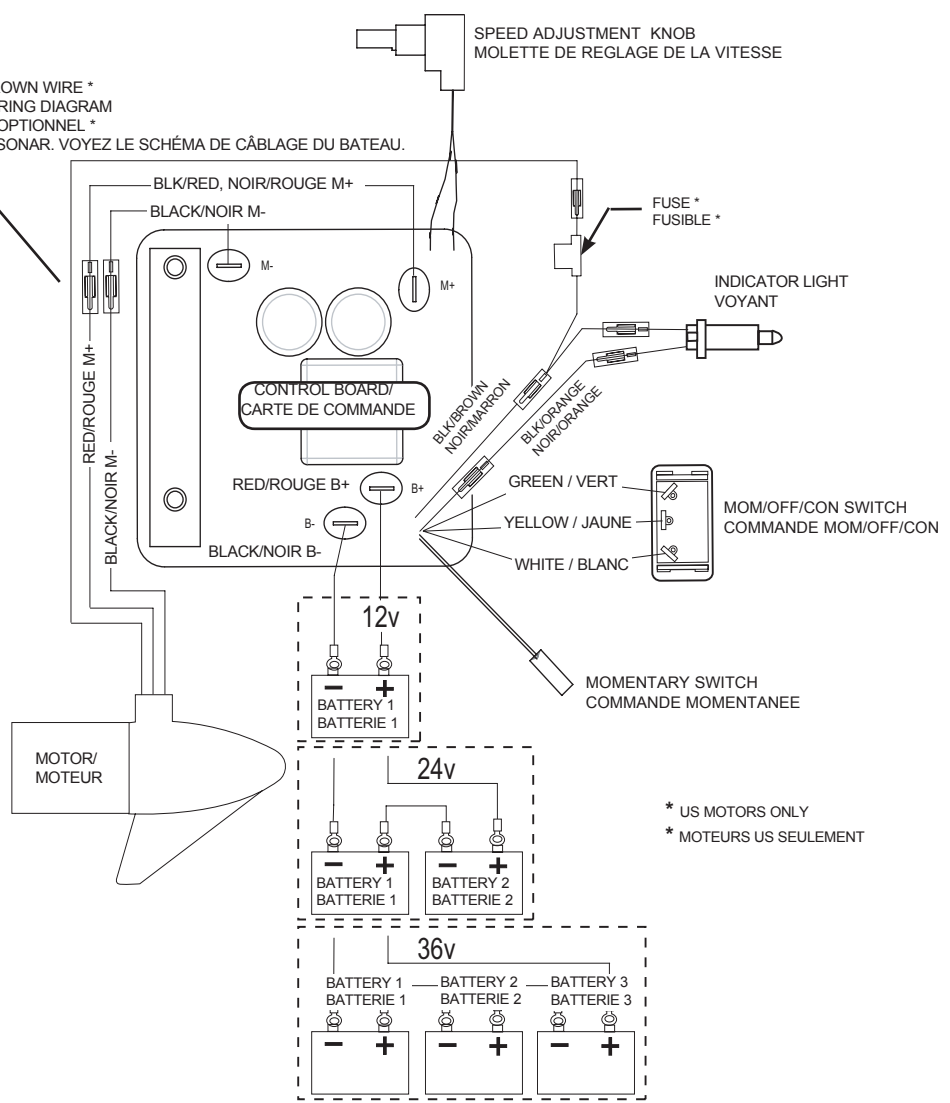

\* US MOTORS ONLY  
 \* MOTEURS US SEULEMENT