

Edge / Maxxum 55
for use with "N" serial numbers
2-year warranty

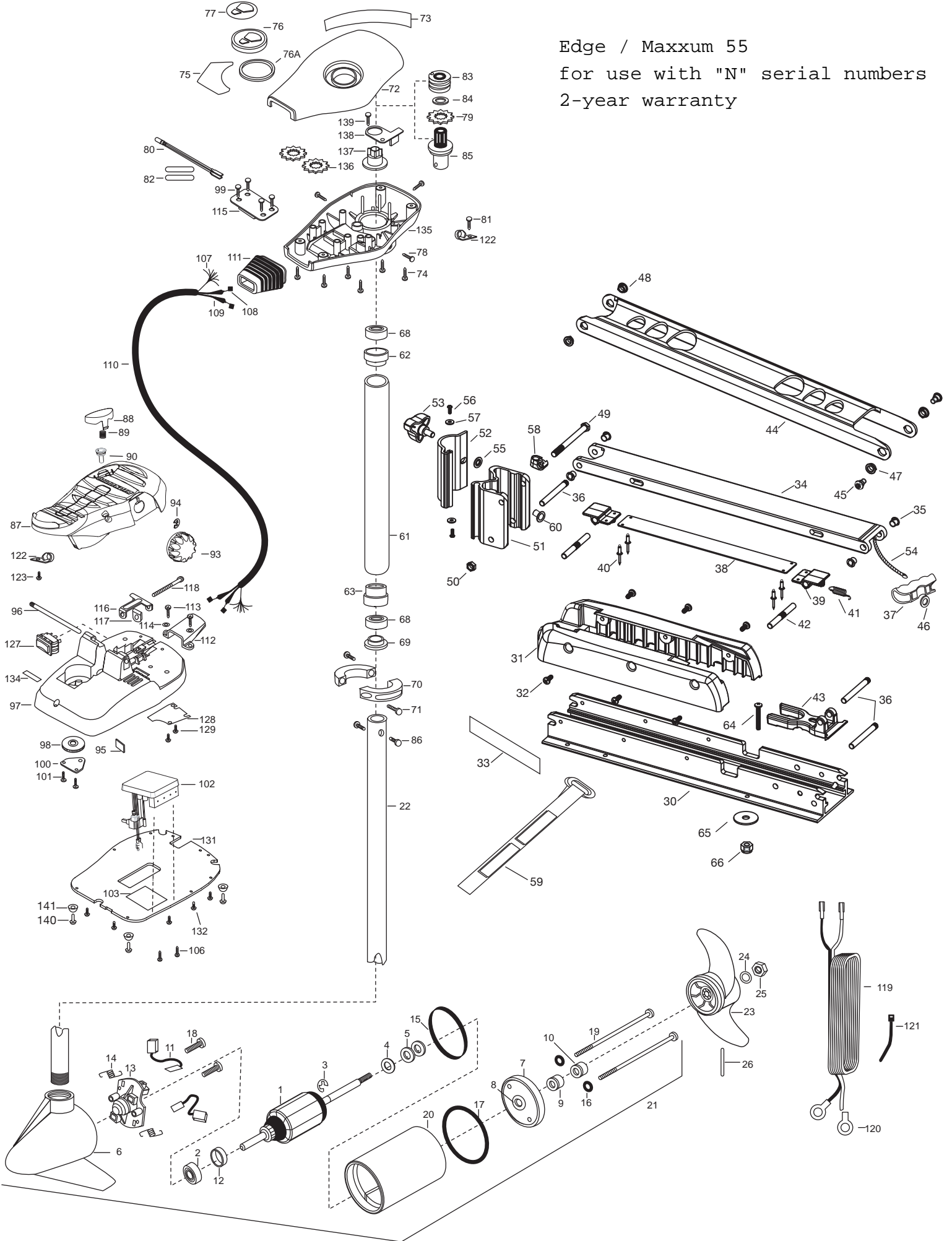

PARTS LIST

ITEM #	QTY	PART NUMBER	DESCRIPTION
1	1	2-100-121	ARMATURE ASSEMBLY 12v 3.625
2	1	140-010	BEARING BALL
3	1	788-015	RETAINING RING
4	1	990-067	WASHER-STEEL THRUST
5	2	990-070	WASHER- NYLATRON
6	1	421-065	BRUSH END HOUSING
7	1	2-400-101	PLAIN END HOUSING ASSEMBLY
8	1	144-049	BEARING -FLANGE
9	1	880-003	SEAL
10	1	880-006	SEAL W/ SHIELD
11	2	188-036	BRUSH ASSEMBLY
12	1	725-050	BRUSH RETENTION
13	1	738-036	BRUSH PLATE W/HOLDER
14	2	975-040	SPRING- TORSION
15	1	337-036	GASKET
16	2	701-008	O-RING
17	1	701-081	O-RING
18	2	830-007	SCREW- SELF THREAD 8-32X1
19	2	830-042	THRU BOLT 10-32X8.83
20	1	2-200-101	CENTER HOUSING FIELD ASSEMBLY
21	1	2097084	MOTOR ASSEMBLY 12V 3.62 VARS
22	1	2032062	TUBE (COMP)W/CSK HOLE-36"
	1	2032063	TUBE (COMP)W/CSK HOLE-42"
■	1	1378131	PROP KIT
*23	1	2091160	PROPELLER W.WEDGE 2
*24	1	2151726	WASHER-5/16 STD SS
*25	1	2053101	NUT- NYLOC 5/16 SS
*26	1	2092600	PIN- DRIVE SS
■	1	2991954	STD-BOWMT FW 30,33,36AT
30	1	2266502	BOWPLATE, FW, STD, 45"
31	1	2263905	MOTOR REST, BLK
32	6	2303430	SCREW 1/4-20 X 5/8"
33	2	2265667	MOTOR REST DECAL, FW
■	1	2991700	ARM-LOWER FW ASSEMBLY
34	1	2264342	ARM-LOWER, FW, STD
35	4	2266002	NYLINER 3/8" SHAFT
36	3	2260503	PIVOT PIN
37	1	2150400	PULL-GRIP
■	1	2993811	LATCH STRAP ASSEMBLY, STD, 45"
38	1	2263605	LATCH STRAP, STD, 45"
39	2	2261902	BRACKET-LATCH
40	4	2268602	RIVET 1/8" SS
41	1	2262709	SPRING-LATCH PIN
42	2	2260501	LATCH PIN

ITEM #	QTY	PART NUMBER	DESCRIPTION
43	1	2261544	YOKE-TUBE
44	1	2264271	ARM-UPPER, SHORT FW
45	2	2263510	BOLT-SHOULDER, SS
46	1	2151700	WASHER-EYE SHAFT (.562 OD)
47	2	2267302	BUSHING-LOWER 7/16" ID, SS
48	2	2267303	BUSHING-UPPER 3/8" IS, SS
49	1	2263505	BOLT 3/8-16 X 4.25"
50	1	2263114	NUT-NYLOCK JAM 3/8-16
51	1	2261872	HINGE BASE, FW
52	1	2261877	HINGE DOOR, FW
53	1	2260905	HANDLE-SOFT GRIP
54	1	2251600	ROPE- (31")
55	1	2261728	WASHER-RETAINING 3/8
56	2	2053415	SCREW #8-32 X 3/8" TRI
57	2	2261732	WASHER #8, NYLON
58	1	2262310	ROPE GUIDE
59	1	2263805	VELCRO STRAP
60	1	2264703	INSERT-THREADED
■	1	2992015	TUBE W/BEARING RACE ASSEMBLY
*61	1	2272066	TUBE OUTER 18" - 4 HOLES
62	1	2266260	BEARING RACE
63	1	2266220	BEARING RACE-STEEL
■	1	2994838	BAG ASSEMBLY-(BOLTS,NUTS,WASHERS)
*64	6	2263462	SCREW 1/4-20 X 2" SS
*65	6	2261713	WASHER-1/4 SS
*66	6	2263103	NUT 1/4-20 NYLOCK, SS
68	2	2266000	BEARING BALL-STEEL
69	1	2266115	BEARING CONE
70	2	2261619	COLLAR HALF-ZINC-2 PER
71	2	2263452	SCREW-1/4-20X3/4
72	1	2260215	CONTROL BOX COVER
73	1	2265507	DECAL-CTRL BOX-TOP/SIDE
74	4	2372100	SCREW-8-18 X 5/8 THD SS
75	1	2275615	DECAL COVER, 55 EDGE/MAXXUM
76	1	2260150	POINTER DISC SHORT YELLOW
76A	1	2261733	WASHER-FOAM, INDICATOR
77	1	2265800	DECAL-INDICATOR
78	3	2053414	SCREW-#8-32 X 1/2 TRI-LOBE
79	1	2267800	GEAR-INDICATOR
80	1	2264015	LIGHT/INDICATOR
81	1	2372100	SCREW-8-18 X 5/8 SS
82	2	2355410	SHRINK TUBE-3/8 OD X 2"
83	1	2232360	PULLEY-CABLE DRUM
84	1	2261730	WASHER-NYLON A/T CON B

ITEM #	QTY	PART NUMBER	DESCRIPTION
85	1	2996246	TOP BEARING RACE/PINION ASSEMBLY
86	2	2263410	SCREW-8-32 X 5/16 (ZN PL)
87	1	2994496	FOOT PEDAL/PLUG ASSEMBLY (AT)
88	1	2993705	PUSH-BUTTON
89	1	2302732	SPRING-LOWER PEDAL SS
90	1	2260810	CLIP, REED SWITCH
93	1	2280115	KNOB-SPEED CONTROL (VAR)
94	1	2263000	E-RING TRU-ARC#5133-43
95	1	2266413	TENSION SCREW PLATE FTPDL
96	1	2260511	PIN-PIVOT A/T FT PDL
97	1	2774550	FOOT PEDAL BASE/PIN ASSEMBLY
98	1	2262301	PULLEY (FOOT PEDAL)
99	4	2223430	SCREW-8X 3/4 PPH TYPE 25 SS
100	1	2266405	COVER-PULLEY (STAMPING)
101	2	2301315	SCREW-8-18 X 1/2 SS
102	1	2264055	CONTROL BOARD ASSEMBLY-12V
103	1	2365107	INSULATING PAD 2.3 X 3.2
106	2	2223455	SCREW, 10-32 X 1/2"
107	1	2261220	WIRE HARNESS AT & MAX
108	1	2267500	CABLE ASSEMBLY-RIGHT (5')
109	1	2267510	CABLE ASSEMBLY-LEFT (5')
110	1	2265430	CABLE JACKET
111	1	2265110	BOOT-FOOT PEDAL BOX
112	1	2265115	BOOT-FOOT PEDAL BASE
113	2	2372100	SCREW-8-18 X 5/8 THD (SS)
114	2	2261714	WASHER-MAXXUM FT PDL
115	1	2261901	BRACKET-CONDUIT
116	1	2263210	BRACKET-CONDUIT ADJUSTMENT
117	1	2263104	NYLOCK KEEPER
118	1	2263463	SCREW-1/4-20 X 2" STL PPH
119	1	2261233	LEADWIRE VARIABLE
120	2	2020700	TERMINAL RING, 3/8"
121	1	2256300	TIE WRAP-5.5" BLACK
122	2	2263201	CLAMP WIRE HARNESS MICRO
123	1	2332103	SCREW-6-20 X 3/8 THD SS
127	1	2254031	SWITCH-MOM/OFF/CON
128	1	2266412	SWITCH PLATE, FT PEDAL
129	2	2332103	SCREW-6-20 X 3/8 THD SS
130	2	2256301	TIE WRAP-5.5" WHITE
131	1	2264511	BOTTOM PLATE, MAXXUM FT
132	8	9953104	SCREW-8 X 1/2" SS
134	1	2266610	DECAL-ON/OFF SWITCH
135	1	2262535	CONTROL BOX-PLASTIC
136	2	2267800	GEAR INDICATOR
137	1	2262220	INDICATOR-DRIVE

ITEM #	QTY	PART NUMBER	DESCRIPTION
138	1	2261905	BRACKET/INDICATOR
139	1	2301310	SCREW-8-18 X 1/2 (SS)
150	1	2266701	PLUG, NYLON PUSH RIVET
■	1	2888460	SEAL & ORING KIT

*THIS ITEM IS PART OF AN ASSEMBLY. THIS ITEM CANNOT BE SOLD SEPARATELY DUE TO MACHINING AND/OR ASSEMBLY THAT IS REQUIRED

MOTOR WIRING DIAGRAM

Edge / Maxxum 55 is 12-volt only!

OPTIONAL BROWN WIRE FOR SONAR EQUIPT MOTORS.
SEE BOAT WIRING DIAGRAM

