

MAX55/SC -42
55 lbs Thrust
12 Volt 50 Amps
42" SHAFT

for use with "N" serial numbers
2-year warranty

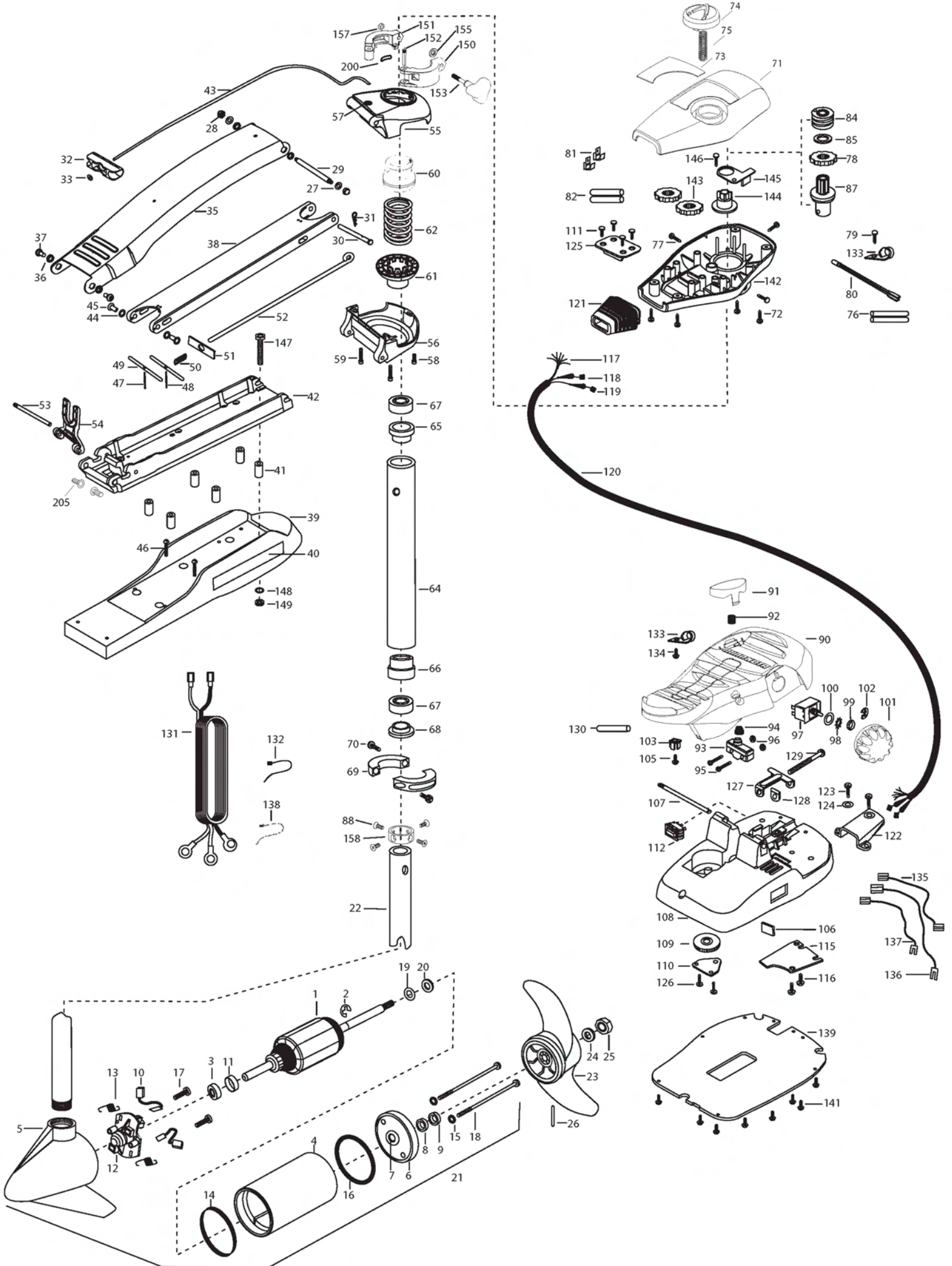

1	2-100-121	ARMATURE ASSEMBLY 12V 3.625 5SPC 55#	53	2260506	HINGE-PIN HEADLESS ZINC	109	2262301	PULLEY- FOOT PEDAL
2	788-015	RETAINING RING	54	2293811	YOKE,MAX MNT-POLYPROPYLENE	110	2266400	COVER-PULLEY STAMPING
3	140-010	BALL BEARING	■	2991762	BOWGUARD ASSEMBLY- FT CTRL FW	111	2223430	SCREW- #8 X3/4 SS PPH TYPE 25 [4.EA]
4	431-101	CENTER HOUSING ASSEMBLY 3.625 FW TXT	55	2772319	BRACKET BASE TOP/EYELET ASSEMBLY	112	2254031	SWITCH-M0M/OFF/CON
5	2-300-196	BRUSH END HOUSING ASSEMBLY 3.62 SPCO	56	2991771	BRKT BTM/BEARING FW ASSEMBLY	115	2266412	SWITCH PLATE, FT PEDAL
6	2-400-101	PLAIN END HOUSING ASSEMBLY	57	2772352	EYELET KIT	116	2332103	SCREW-6-20 X 3/8 THD SS [2.EA]
7	144-049	BEARING - FLANGE (SERVICE ONLY)	58	2263423	SCREW 5/16-18 X 1" SHCS ZINC	117	2261208	WIRE HARNESS, A/T FT. PHD
8	880-003	SEAL	59	2263425	SCREW 5/16-18 X 2 1/2" SHCS [2.EA]	118	2267505	CABLE ASSY-RIGHT (5')
9	880-006	SEAL WITH SHIELD	60	2071541	SPRING-SLEEVE UPPER	119	2267515	CABLE ASSY-LEFT (5')
10	188-036	BRUSH ASSEMBLY [2.EA]	61	2071535	SPRING SLEEVE, LOWER	120	2265430	CABLE JACKET (5')
11	725-050	BRUSH RETENTION- PAPER TUBE	62	2262706	SPRING, BOWGUARD, NIK PL	121	2265110	BOOT-CONTROL BOX
12	738-036	BRUSH PLATE W/HOLDER	■	2772012	TUBE W/BEARING RACE ASSEMBLY	122	2265115	BOOT-FOOT PEDAL BASE
13	975-040	SPRING - TORSION [2.EA]	64	2272069	TUBE OUTER-21" 4 HOLES	123	2372100	SCREW-8-18 X 5/8 THD SS [2.EA]
14	337-036	GASKET	65	2266260	BEARING RACE	124	2261714	WASHER-MAXXUM FT PDL [2.EA]
15	701-008	O-RING, THRU-BOLT [2.EA]	66	2266220	BEARING RACE-STEEL	125	2261901	BRACKET-CONDUIT
16	701-081	O-RING	67	2266000	BEARING BALL-STEEL [2.EA]	126	2301310	SCREW-8-18 X 1/2 SS [2.EA]
17	830-007	SCREW-8-32 [2.EA]	68	2266115	BEARING CONE	127	2263210	BRACKET-CONDUIT ADJUSTMENT
18	830-042	THRU-BOLT 10-32X8.83" [2.EA]	69	2771617	COLLAR HALF-ZINC- 2 PER KIT	128	2263104	NYLOCK KEEPER
19	990-067	WASHER- STEEL THRUST	70	2263452	SCREW-1/4-20 X 3/4" SHCS [2.EA]	129	2263463	SCREW-1/4-20 X 2" STL PPH
20	990-070	WASHER - NYLATRON [2.EA]	71	2280201	CONTROL BOX COVER	130	2355410	SHRINK TUBE-3/8 OD X 2"
21	2097087	MOTOR ASSEMBLY 12V 3.625 5SPC FW 55#	72	2372100	SCREW-8-18 X 5/8" THD SS [4.EA]	131	2261225	LEADWIRE- BATTERY
22	2032003	TUBE (COMP) 4 HOLE-42"	73	2275601	DECAL-COVER	132	2256300	TIE WRAP-5.5" BLACK
■	1378131	PROP KIT	74	2990140	DIRECTIONAL INDICATOR	133	2263201	CLAMP WIRE HARNESS MICRO [2.EA]
23	2091160	PROPELLER (W.WEDGE 2)	75	2282730	SPRING, INDICATOR	134	2332103	SCREW-6-20 X 3/8 THDT SS
24	2151726	WASHER-5/16 STD SS	76	2375400	SHRINK TUBE-1/4OD X 1-3/4" [2.EA]	135	2260301	CONNECTING WIRE (SWITCH)
25	2053101	NUT-PROP,NYLOC (MED) 5/16 SS	77	2053414	SCREW-#8-32 X 1/2" TRI-LOBE [3.EA]	136	2260312	WIRE,BLK W/WHT STRP 19 1/2
26	2092600	PIN-DRIVE (95-4HP'S) SS	78	2267800	GEAR-INDICATOR	137	2260322	WIRE,BLK W/BLUE STRP-12"
27	9008236	WASHER 1/4 FLAT ZINC [4.EA]	79	2372100	SCREW-8-18 X 5/8" SS	138	2256301	TIE WRAP-5.5" WHITE
28	2223100	NUT- TENSION 5/16-18 SS [2.EA]	80	2264015	LIGHT/INDICATOR	139	2266414	BOTTOM PLATE MAX FOOT PED
29	2262605	PIN- BWGRD UPPER THREADED	81	2020713	TERMINAL-ADAPTOR, MAX [2.EA]	141	9953104	SCREW-8 X 1/2" SS [8.EA]
30	2262607	CLEVIS PIN ZP MAXXUM BWGRD	82	2335400	SHRINK TUBE-1/2 OD X 2" [2.EA]	142	2282500	CONTROL BOX
31	2260805	SPRING CLIP	84	2232360	PULLEY-CABLE DRUM	143	2267800	GEAR-INDICATOR [2.EA]
32	2150400	PULL-GRIP	85	2261730	WASHER-NYLON A/T CON B	144	2262221	INDICATOR-DRIVE
33	2151700	WASHER-EYE SHAFT(.562 OD)	87	2996247	TOP BEARING RACE/ PINION DR	145	2261905	BRACKET/INDICATOR
■	2991840	MOUNT- BOW ASSEMBLY, W/O BGRD FW STD	88	2223468	SCREW-8-32 X 7/16" ZN PL [4.EA]	146	2301310	SCREW-8-18 X 1/2" SS
35	2264241	ARM-UPPER FW,STD	90	2994496	FOOT PEDAL/PLUG ASSEMBLY (AT)	■	2994830	BAG ASSEMBLY-MAXXUM
36	2293501	BUSHING, STAINLESS STEEL [4.EA]	91	2283700	PUSH-BUTTON FOOT PEDAL	*147	2263431	SCREW 1/4-20 X 3.5" PPH [6.EA]
37	2263500	BOLT- SHOULDER (MAXXUM) [2.EA]	92	2302732	SPRING-LOWER PEDAL SS	*148	2261713	WASHER-1/4 FLAT SS [6.EA]
38	2994307	ARM-LOWER ASSEMBLY,STD,FW,EXT	93	2264020	SWITCH MOMENTARY	*149	2263103	NUT-1/4-20 NYLOCK-JAM SS [6.EA]
39	2263912	MOTOR REST STD MAXXUM	94	2265140	BOOT-MICROSWITCH	■	2991550	CLAMP COLLAR ASSEMBLY
40	2265514	DECAL-MAXXUM,MOTOR REST [2.EA]	95	2262114	SCREW-MOUNTING/SWITCH [2.EA]	150	2071550	CLAMP COLLAR "A"
41	2261505	SPACER, MOTOR REST [6.EA]	96	2233100	NUT-SWITCH MOUNT [2.EA]	151	2071555	CLAMP COLLAR "B"
42	2773987	BOWPLATE/INST ASSEMBLY STD FW	97	2264026	SWITCH-5 SPEED (ALL TERRAIN)	152	2072621	PIN-KNURLED
43	2251601	ROPE (40"), MAXXUM MOUNT	98	2261701	LOCKWASHER-STAR	153	2281505	KNOB-CLAMP COLLAR
44	2261708	WASHER-3/8X1/2X.010" SS [2.EA]	99	2263105	NUT-HEX	155	2071718	WASHER #10 NYLON RETAINING
45	2267318	BEARING NYLINER-[2.EA]	100	2261715	SPACER-SWITCH 5 SP MODELS	157	2073102	NUT - HEX 1/4 - 28 SS
46	2263434	SCREW, 8-18 X 1" PPH SS [2.EA]	101	2280110	KNOB-SPEED CONTROL (5 SPD)	158	2071560	SPLIT COLLAR
47	2152610	SPRING-PIN LOCKBAR [2.EA]	102	2263000	E-RING TRU-ARC#5133-43	200	2075120	URETHANE PAD
48	2233600	LOCK BAR- BOW MOUNT	103	2260730	CONNECTOR 1/4 MALE TAB OD	205	2261540	INSERT-THREADED BOWPLATE (2 EA)
49	2233602	LOCK BAR, REAR - ZINC	105	2332103	SCREW-6-20 X 3/8" THD SS			
50	2152700	SPRING-LOCKBAR CAD.PLTD	106	2266413	TENSION SCREW PLATE FTPED			
51	2262703	SPRING STOP	107	2260511	PIN-PIVOT A/T FT PDL			
52	2153602	EYE SHAFT-2LOCKBAR STD-PL	108	2992102	FT PED BASE/PIN ASSEMBLY SONAR			

2888460 SEAL & ORING KIT

* This item is part of an assembly. This item cannot be sold separately due to machining and /or assembly that is required.

