

MAXXUM 70
70 lbs Thrust
24 Volt 42 Amps
42" SHAFT

for use with "N" serial numbers
2-year warranty

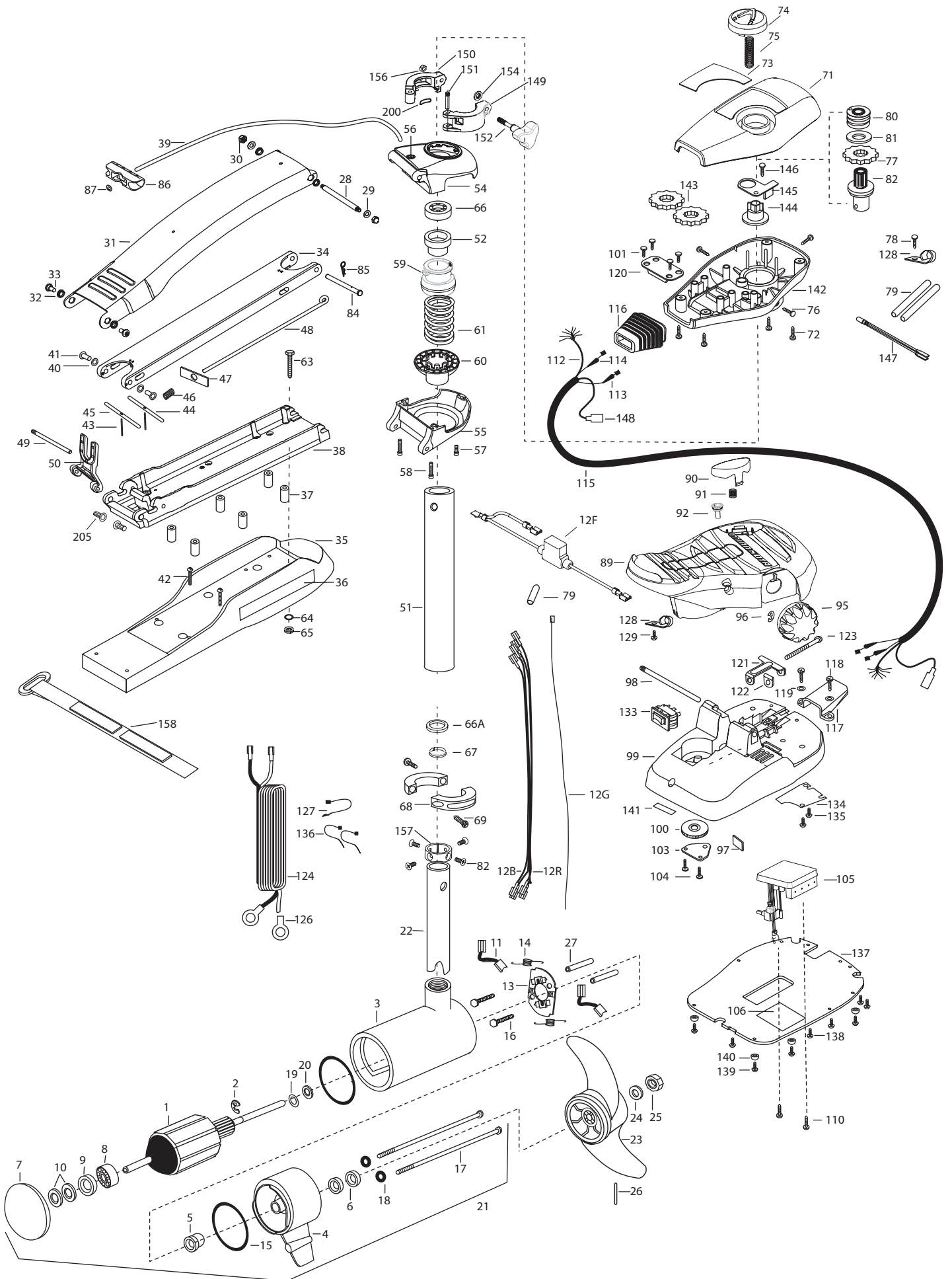

1	2-100-271	ARMATURE ASSEMBLY 24V 4"	47	2262703	SPRING STOP- MAXXUM	101	2223430	SCREW- #8X3/4 PPH TYPE 25 SS [4.EA]
2	788-040	RETAINING RING	48	2153602	EYE SHAFT-2LOCKBAR STD	103	2266400	COVER- PULLEY
3	2-200-160	CENTER HOUSING ASSEMBLY 4.0 TXT	49	2260506	HINGE-PIN HEADLESS ZINC	104	2301310	SCREW- 8-18 X 1/2 [4.EA]
4	2-300-160	BRUSH END HOUSING ASSEMBLY	50	2293811	YOKE- MAXXUM MOUNT,POLYPROPYLENE	105	2264056	CTRL BOARD ASSEMBLY 24-36V MAX
5	144-017	BEARING- FLANGE (SERVICE ONLY)	■	2992085	TUBE W/BEARING RACE ASSEMBLY	106	2365107	INSULATING PAD (2.3X3.2)
6	880-025	SEAL [2.EA]	51	2272085	TUBE OUTER-21" 4 HOLES	110	2223455	SCREW- 10-32 X 1/2" [2.EA]
7	421-276	PLAIN END HOUSING ASSEMBLY	52	2266260	BEARING RACE	112	2261220	WIRE HARNESS AT & MAX
8	140-010	BALL BEARING				113	2267505	CABLE ASSEMBLY- RIGHT (5')
9	990-045	THRUST SPACER	■	2991762	BOWGUARD ASSEMBLY- FT CTRL,FW	114	2267515	CABLE ASSEMBLY- LEFT (5')
10	992-010	SPRING WASHER	54	2772319	BRACKET BASE TOP/ EYELET ASSEMBLY	115	2265430	CABLE JACKET (5')
11	186-094	BRUSH [2.EA]	*55	2991771	BRKT BOTTOM/BEARING FW ASSEMBLY	116	2265110	BOOT- CONTROL BOX
12B	640-017	LEADWIRE-BLACK 10 AWG 61 XLP	56	2772352	EYELET- KIT	117	2265115	BOOT- FOOT PEDAL BASE
12R	640-121	LEADWIRE-RED 10 AWG 62 1/2	57	2263423	SCREW 5/16-18 X 1" SHCS ZINC	118	2372100	SCREW- 8-18X5/8 THD [2.EA]
12G	640-317	BROWN GROUND WIRE (US MOTORS ONLY)	58	2263425	SCREW 5/16-18 X 2 1/2 SHCS [2.EA]	119	2261714	WASHER- MAXXUM FT PDL [2.EA]
12F	2218200	FUSE HOLDER (US MOTORS ONLY)	59	2071541	SPRING SLEEVE- UPPER	120	2261901	BRACKET- CONDUIT
13	738-040	BRUSH PLATE 4"	60	2071535	SPRING SLEEVE- LOWER	121	2263210	BRACKET- CONDUIT ADJUST
14	975-041	SPRING- TORSION [2.EA]	61	2262712	SPRING- BOWGUARD, NIK PL	122	2263401	NYLOCK KEEPER
15	701-043	O-RING [2.EA]	■	2994830	BAG ASSEMBLY- MAXXUM	123	2263463	SCREW- 1/4-20X2" STL PPH
16	830-027	SCREW -SELF THREAD 10-32X2 [2.EA]	*63	2263431	SCREW- 1/4-20 X 3.5 PPH [6.EA]	124	2261233	LEADWIRE- A/T VARIABLE
17	830-094	THRU BOLT 12-24X10.31 [2.EA]	*64	2261713	WASHER- 1/4 FLAT S/S [6.EA]	126	2020700	TERMINAL RING- 3/8" [2.EA]
18	701-009	O-RING —THRU BOLT [2.EA]	*65	2263103	NUT- 1/4-20 NYLOCK-JAM SS [6.EA]	127	2256300	TIE WRAP- 5.5' BLACK
■	2889460	SEAL & ORING KIT	66	2266000	BEARING BALL- STEEL	128	2263201	CLAMP WIRE HARNESS MICRO [2.EA]
19	990-051	WASHER- STEEL	66A	2266116	BEARING, CARTRIDGE	129	2332103	SCREW- 6-20X3/8 THD (SS)
20	990-052	WASHER- NYLATRON	*67	2266001	BEARING, SPLIT RING	133	2254031	SWITCH- MOM/OFF/CON
21	2316223	MOTOR ASSEMBLY 24V F/W	*68	2261619	COLLAR HALF- ZINC [2.EA]	134	2266412	SWITCH PLATE- FT PEDAL
22	2032003	TUBE- COMPOSITE W/4 HOLE 42"	*69	2263452	SCREW- 1/4-20X3/4 [2.EA]	135	2332103	SCREW- 6-20X3/8 THD SS [2.EA]
■	1378132	PROPELLER KIT	71	2280201	CONTROL BOX COVER	136	2256301	TIE WRAP- 5.5' WHITE [2.EA]
23	2331160	PROPELLER W.WEDGE II	72	2372100	SCREW- 8-18 X 5/8 THD [4.EA]	137	2774511	BOTTOM PLATE- MAXXUM FT
24	2091701	WASHER- SS	73	2275604	DECAL- COVER MAX70/FC	138	9953104	SCREW-8 X 1/2" (SS) [5.EA]
25	2093101	NUT-PROP NYLOC	74	2990140	DIRECTIONAL INDICATOR	139	2263455	SCREW- #12-14X1/2 THR FRM [4.EA]
26	2262658	PIN-DRIVE	75	2282730	SPRING - INDICATOR	140	2265126	BUMPER PAD- FOOT PEDAL [4.EA]
27	973-025	SPACER- BRUSH PLATE [2.EA]	76	2053414	SCREW- 8-32 X 1/2 TRI-LOBE [3. EA]	141	2266610	DECAL- ON/OFF SWITCH
28	2262605	PIN- BWGRD UPPER THREADED ZP	77	2267800	GEAR- INDICATOR	142	2282500	CONTROL BOX
29	9908236	WASHER- 1/4 FLAT ZINC [2.EA]	78	2372100	SCREW- 8-18 X 5/8	143	2267800	GEAR- INDICATOR [2.EA]
30	2223100	NUT- TENSION 5/16-18 SS [2.EA]	79	2355410	SHRINK TUBE- 3/8 OD X 2" [2.EA]	144	2262221	INDICATOR- DRIVE
■	2771840	MOUNT- BOW ASSEMBLY, STD FW MAX	80	2232360	PULLEY- CABLE DRUM	145	2261905	BRACKET/INDICATOR
31	2264241	ARM-UPPER STD FW	81	2261730	WASHER- NYLON A/T CON	146	2301310	SCREW- 8-18X1/2"
32	2293501	BUSHING- STAINLESS STEEL [4.EA]	82	2996247	TOP BEARING RACE /PINION DRIVE	147	2264015	LIGHT/INDICATOR
33	2263500	BOLT- SHOULDER MAXXUM [2.EA]	83	2223468	SCREW- 8-32 X 7/16 [4.EA]	148	2211400	EXTENSION CABLE- SONAR
34	2774315	ARM-LOWER ASSEMBLY,STD,FW,EXTRA [INCLUDES 39, 43-47, 86,87]	84	2262607	PIN- CLEVIS ZP MAXXUM BWGRD	■	2991550	CLAMP COLLAR ASSEMBLY
			85	2260805	CLIP- SPRING ZP MAX BG	149	2071550	CLAMP COLLAR "A"
35	2263912	MOTOR REST (STD) FW	86	2150400	PULL- GRIP	150	2071555	CLAMP COLLAR "B"
36	2265514	DECAL- MAXXUM MOTOR REST [2.EA]	87	2151700	WASHER- EYE SHAFT(.562 OD)	151	2072621	PIN-KNURLED
37	2261505	SPACER- MOTOR REST [6.EA]	89	2994496	FOOT PEDAL/PLUG ASSEMBLY	152	2281505	KNOB-CLAMP COLLAR
38	2773987	BOWPLATE- W/INSERT	90	2993705	PUSH- BUTTON MAGNET ASSY	154	2071718	WASHER #10 NYLON RETAINING
39	2251601	ROPE (40"), MAXXUM MOUNT	91	2302732	SPRING- LOWER PEDAL	156	2073102	NUT - HEX 1/4 - 28 SS
40	2261708	WASHER- 3/8X1/2X.010 SS [2.EA]	92	2260810	CLIP, REED SWITCH	157	2071560	SPLIT COLLAR
41	2267318	BEARING NYLINER [2.EA]	95	2280115	KNOB- SPEED CONTROL (VAR)	158	2263804	STRAP - VELCRO 30.5"
42	2263434	SCREW, 8-18X1" PPH [2.EA]	96	2263000	E-RING THU-ARC	200	2075120	URETHANE PAD
43	2152610	SPRING- PIN LOCKBAR [2.EA]	97	2266413	TENSION SCREW PLATE FTPEDAL	205	2261540	INSERT-THREADED BOWPLATE (2 EA)
44	2233600	LOCK BAR- BOW MOUNT	*98	2260511	PIN- PIVOT A/T FT PDL			
45	2233602	LOCK BAR REAR - ZINC	99	2774550	FT PEDAL BASE/PIN ASSEMBLY			
46	2152700	SPRING- LOCKBAR CAD.PLTD	100	2262301	PULLEY- FOOT PEDAL			

* This item is part of an assembly. This item cannot be sold separately due to machining and /or assembly that is required.

THIS IS A UNIVERSAL MULTI-VOLTAGE DIAGRAM. DOUBLE CHECK YOUR MOTORS VOLTAGE FOR PROPER CONNECTIONS
CECI EST UN SCHÉMA À TENSION MULTIPLE UNIVERSEL. REVÉRIFIEZ LA TENSION DE VOTRE MOTEUR POUR BIEN LE BRANCHER.

Maxxum 70 is 24-volt only!

OPTIONAL BROWN WIRE *
 SEE BOAT WIRING DIAGRAM
 FIL MARRON OPTIONNEL *
 ÉQUIPÉS DE SONAR. VOYEZ LE SCHÉMA DE CÂBLAGE DU BATEAU.

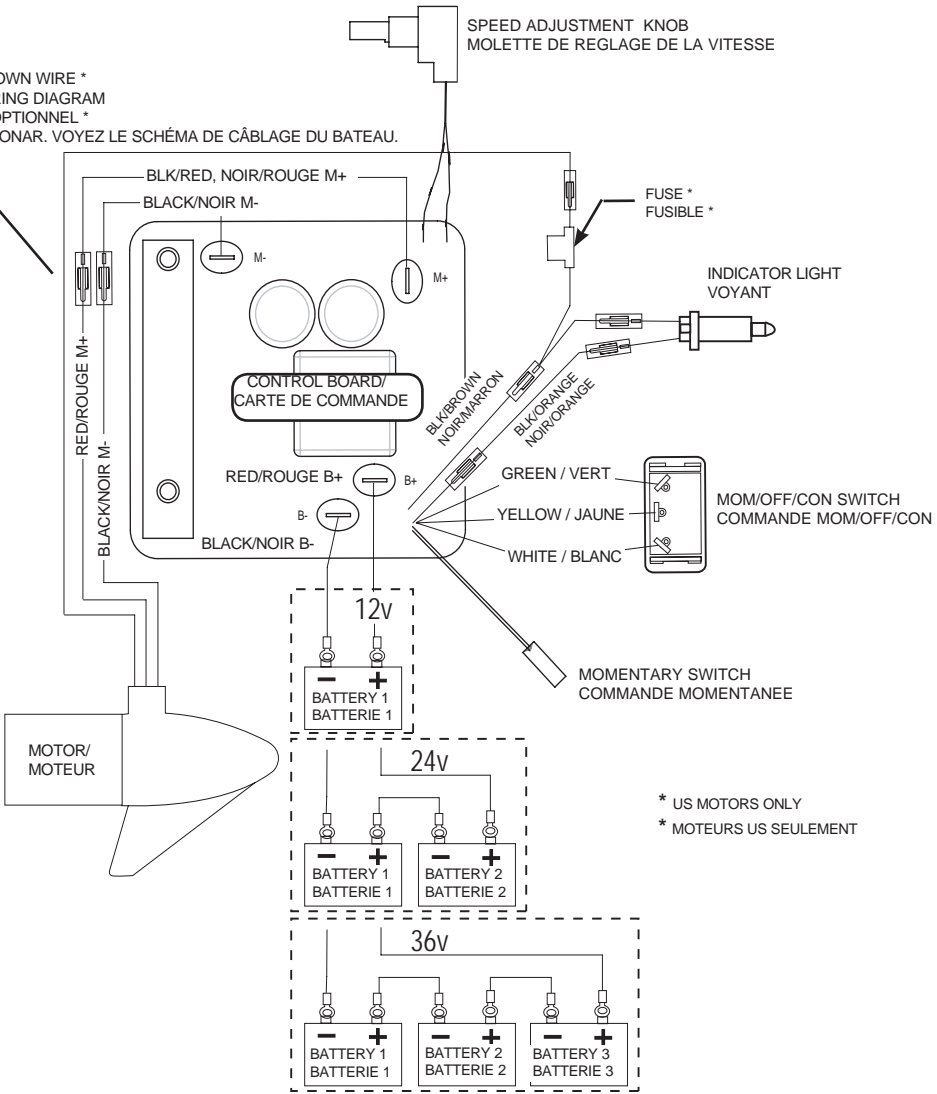

* US MOTORS ONLY
 * MOTEURS US SEULEMENT