

MAXXUM 80/HC
80 LBS THRUST
24 VOLT 56 AMPS
52" SHAFT

for use with "N" serial numbers
2-year warranty

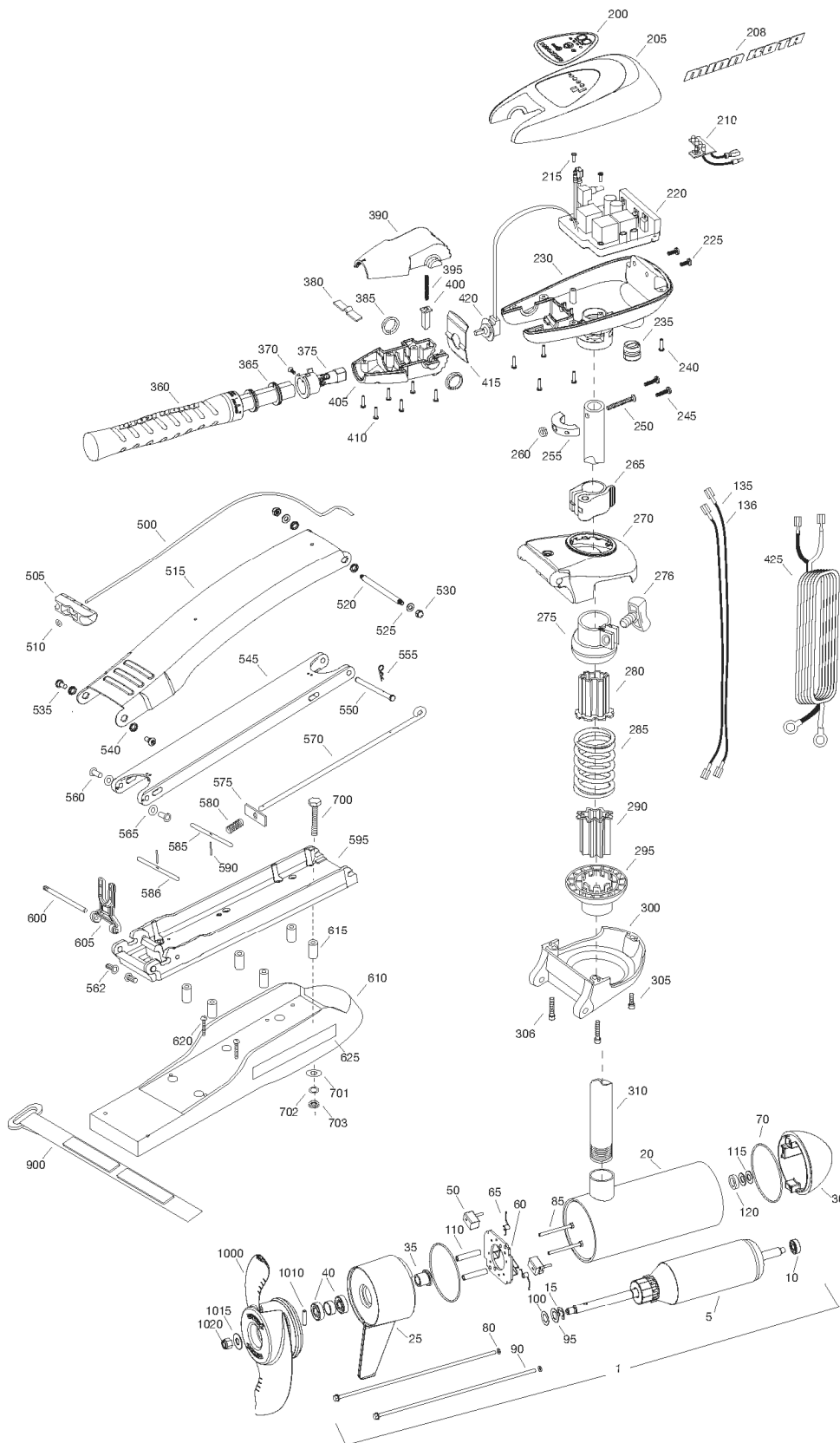

Item	P/N	Description	Qty	Item	P/N	Description	Qty	Item	P/N	Description	Qty
1	2316217	24V Motor 52" FW	1	■	2990957	Handle assy, VARS [360-410]	1	900	2263804	Strap, hold down	1
5	2-100-214	Armature assembly	1	360	2990456	Grip/handle assy, VARS [360-375]	1				
10	140-010	Bearing	1	365	2060015	Bearing, handle	2	■	1378132	Propeller kit WW2	
15	788-040	Retaining ring	1	370	2063405	Screw, #6 PFH SS	1	■	2994876	Propeller bag assy	
20	2-200-160	Center housing assembly	1	375	2884092	Yoke / spider assy, VARS	1	1000	2331160	Propeller WW2	1
25	2-300-160	Brush end housing assembly	1	380	2302742	Spring, detent, off	1	1010	2262658	Drive pin, large	1
30	421-276	Plain end housing assembly STD	1	385	2060005	Bearing, handle pivot	2	1015	2091701	Washer, prop, large	1
35	144-017	Flange bearing	1	390	2060900	Handle pivot, top	1	1020	2093101	Nut, nylock, prop, large	1
40	880-025	Seal	2	395	2302745	Spring, release button	1				
50	188-094	Brush	2	400	2063700	Button, release	1				
60	9-738-004	Brush plate assembly	1	405	2060905	Handle pivot, bottom	1				
65	975-041	Brush spring	2	410	2303412	Screw, #6 x 5/8 SS	6				
70	701-043	O-ring, motor	2								
80	701-009	O-ring, thru-bolt	2	415	2062715	Spring, handle pivot	1				
85	830-027	Screw, 10-32 x 2	2	420	2061700	Washer, pot holder	1				
90	830-094	Thru-bolt	2	425	2992523	Leadwire assy	1				
95	990-051	Washer, steel	2								
100	990-052	Washer, nylon	2	■	2991840	Mount, Bow Assy W/ Bowguard	1				
110	973-025	Spacer, brush plate	2			[270-306], [500-625]					
115	992-010	Washer, Belleville	2	500	2251601	Rope	1				
120	992-045	Spacer, thrust	1	505	2150400	Pull grip	1				
135	640-018	Leadwire, black	1	510	2151700	Washer	1				
136	640-123	Leadwire, red	1	515	2264241	Arm, upper, std, fw	1				
■	2889460	Seal and O-ring Kit		520	2262605	Pin, bowguard, upper	1				
				525	9908236	Washer, 1/4", ZP	2				
200	2185615	Decal, c-box cover	1	530	2223100	Nut, 5/16-18 SS	2				
205	2060295	C-box cover	1	535	2263500	Bolt, shoulder	2				
208	2065665	Decal - MinnKota	2	540	2293501	Bushing, SS	2				
210	2074071	Battery meter, 24v FW	1	545	2994307	Arm, Lower, std, fw	1				
215	2043427	Screw, #8 x 7/8 SS	2	550	2262607	Pin, clevis ZP	1				
220	2184017	Control board, 24/36V	1	555	2260805	Spring, clip	1				
■	2888411	Potentiometer Replacement Kit		560	2261318	Bushing, nylon	2				
225	2303434	Screw, #8-30 x 5/8 SS	2	562	2261540	Insert-threaded bowplate	2				
230	2062501	Control box, VARS, FW	1	565	2261708	Washer, spacer, .010 thk	2				
235	2062905	Strain relief	1	570	2153602	Eyeshaft, ZP	1				
240	2303412	Screw, #6 x 5/8 SS	6	575	2262703	Spring stop	1				
245	2263434	Screw, #8 x 1 SS	2	580	2152700	Spring, lock bar	1				
250	2383407	Screw, #10-24 x 2 SS	1	585	2233622	Lock bar, front, ZP	1				
255	2061515	Collar, c-box	1	586	2233620	Lock bar, back, ZP	1				
260	2383124	Nut, 10-24, nylock, SS	1	590	2152610	Spring pin	2				
265	2991521	Cam lock/depth collar assy	1	595	2773987	Bowplate w/ insert, std, fw	1				
				600	2260506	Hinge pin, ZP	1				
■	2991760	Bowguard Assembly [270-306]	1	605	2293811	Yoke, Max	1				
270	2261976	Bracket, top	1	610	2263912	Motor rest, std, fw	1				
275	2261525	Spring sleeve, Upper	1	615	2261505	Spacer, motor rest	6				
276	2011365	Knob, collar	1	620	2263434	Screw, #8, SS	2				
280	2264702	Tube insert, bowmount	2	625	2265514	Decal, motor rest	2				
285	2262711	Spring, bowguard	1								
295	2261535	Spring sleeve, Lower	1	■	2994830	Bag assembly	1				
300	2991775	Bracket Assy, bottom	1	700	2263431	Screw, 1/4-20 x 3 1/2" PPH, SS	6				
305	2263423	Screw, 5/16 x 1" SHCS ZP	1	701	2301720	Washer, rubber mounting	6				
306	2263425	Screw, 5/16 x 2.5" SHCS ZP	2	702	2261713	Washer, 1/4 SS	6				
				703	2263101	Nut, 1/4-20 Nylock, SS	6				
310	2032068	Tube Composite 52"	1								

* This item is part of an assembly. This item cannot be sold separately due to machining and /or assembly that is required.

12-24-36 VOLT VARIABLE SPEED MODELS MODÈLES 12-24-36 V VITESSE VARIABLE

THIS IS A UNIVERSAL MULTI-VOLTAGE DIAGRAM. DOUBLE CHECK YOUR MOTORS VOLTAGE FOR PROPER CONNECTIONS
CECI EST UN SCHEMA À TENSION MULTIPLE UNIVERSEL. REVÉRIFIEZ LA TENSION DE VOTRE MOTEUR POUR BIEN LE BRANCHER.

Maxxum 80 is 24-volt only!

