

**MAX 55/SC/B - 42"**  
**55 lbs Thrust**  
**12 Volt 45 Amps**  
**42" SHAFT**

*for use with motors with serial numbers beginning MKAE*  
*3-year warranty from the date of purchase*

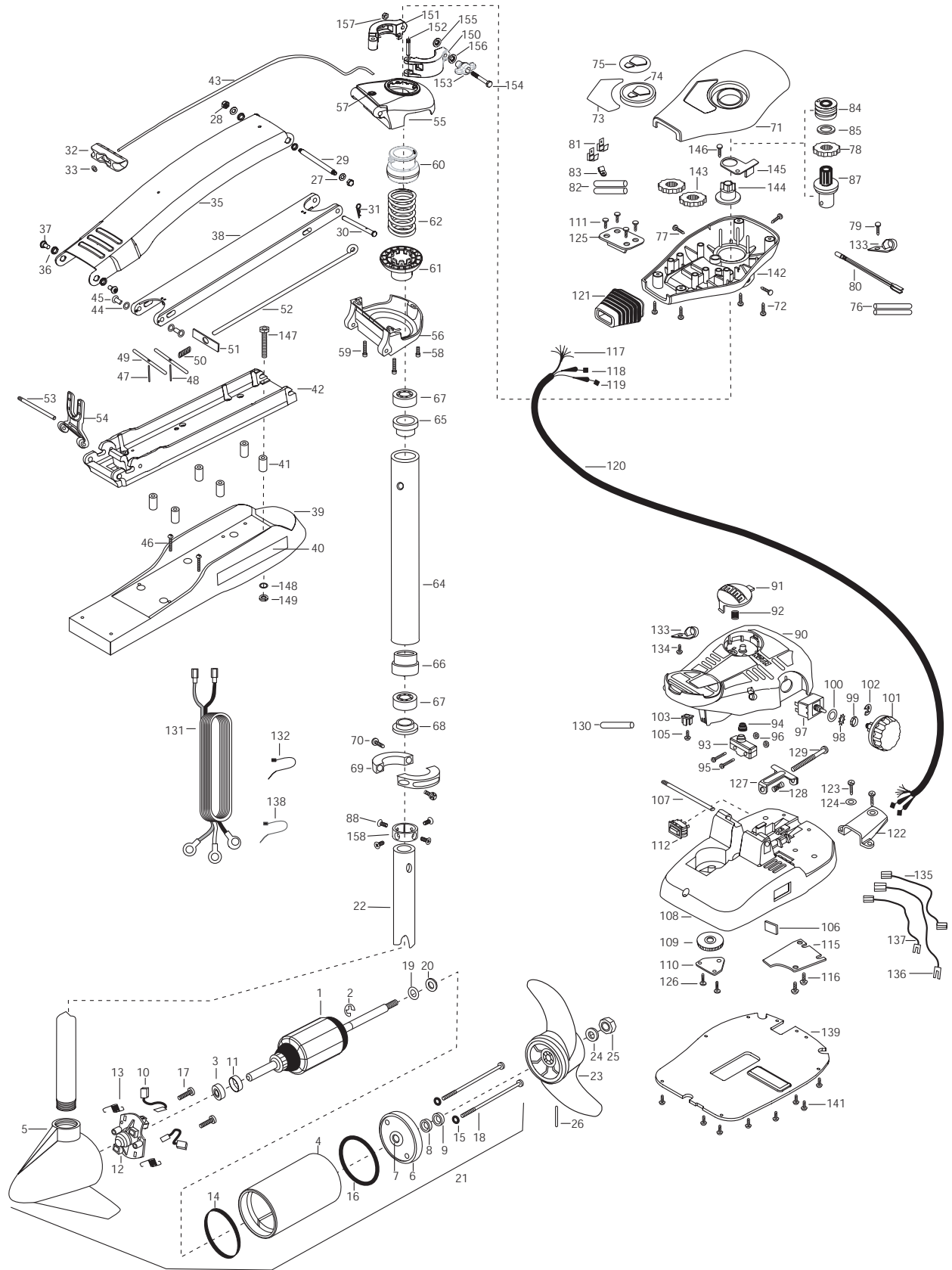

1	2-100-013	ARMATURE ASSEMBLY 12V 3.625 5SPC 55#	53	2260506	HINGE-PIN HEADLESS ZINC	108	2992102	FT PED BASE/PIN ASSEMBLY SONAR
2	788-015	RETAINING RING	54	2293811	YOKE,MAX MNT-POLYPROPYLENE	109	2262301	PULLEY- FOOT PEDAL
3	140-010	BALL BEARING	■	2991893	BOWGUARD ASSEMBLY- FT CTRL FW	110	2266400	COVER-PULLEY STAMPING
4	431-101	CENTER HOUSING ASSEMBLY 3.625 FW TXT	55	2772315	BRACKET BASE TOP/EYELET ASSEMBLY	111	2223430	SCREW- #8 X3/4 SS PPH TYPE 25 [4.EA]
5	2-300-196	BRUSH END HOUSING ASSEMBLY 3.62 SPCO	56	2991999	BRKT BTM/BEARING FW ASSEMBLY	112	2254031	SWITCH-MOM/OFF/CON
6	2-400-101	PLAIN END HOUSING ASSEMBLY	57	2772352	EYELET KIT	115	2266412	SWITCH PLATE, FT PEDAL
7	144-049	BEARING - FLANGE (SERVICE ONLY)	58	2263402	SCREW 1/4-20 X 3/4" ZINC	116	2332103	SCREW-6-20 X 3/8 THD SS [2.EA]
8	880-003	**SEAL	59	2263404	SCREW-1/4-20X2 1/4" SHCP SS [2.EA]	117	2261208	WIRE HARNESS, A/T FT. PHD
9	880-006	**SEAL WITH SHIELD	60	2071541	SPRING-SLEEVE UPPER	118	2267500	CABLE ASSY-RIGHT (5')
10	188-036	BRUSH ASSEMBLY [2.EA]	61	2071535	SPRING SLEEVE, LOWER	119	2267510	CABLE ASSY-LEFT (5')
11	725-050	BRUSH RETENTION- PAPER TUBE	62	2262706	SPRING, BOWGUARD, NIK PL	120	2265430	CABLE JACKET (5')
12	738-036	BRUSH PLATE W/HOLDER	■	2772012	TUBE W/BEARING RACE ASSEMBLY	121	2265110	BOOT-CONTROL BOX
13	975-040	SPRING - TORSION [2.EA]	64	2272069	TUBE OUTER-21" 4 HOLES	122	2265115	BOOT-BOOT PEDAL BASE
14	337-036	**GASKET	65	2266260	BEARING RACE	123	2372100	SCREW-8-18 X 5/8 THD SS [2.EA]
15	701-008	**O-RING, THRU-BOLT [2.EA]	66	2266220	BEARING RACE-STEEL	124	2261714	WASHER-MAXXUM FT PDL [2.EA]
16	701-081	**O-RING	67	2266000	BEARING BALL-STEEL [2.EA]	125	2261901	BRACKET-CONDUIT
17	830-007	SCREW-8-32 [2.EA]	68	2266115	BEARING CONE	126	2301310	SCREW-8-18 X 1/2 SS [2.EA]
18	830-042	THRU-BOLT 10-32X8.83" [2.EA]	69	2771617	COLLAR HALF-ZINC- 2 PER KIT	127	2263210	BRACKET-CONDUIT ADJUSTMEN
19	990-067	WASHER- STEEL THRUST	70	2263452	SCREW-1/4-20 X 3/4" SHCS [2.EA]	128	2262720	SPRING-CONDUIT AD
20	990-070	WASHER - NYLATRON [2.EA]	71	2260283	CONTROL BOX COVER -MAXXUM	129	2263463	SCREW-1/4-20 X 2" STL PPH
21	2099092	MOTOR ASSEMBLY 12V 3.625 5SPC FW 55#	72	2372100	SCREW-8-18 X 5/8" THD SS [4.EA]	130	2355410	SHRINK TUBE-3/8 OD X 2"
22	2032003	TUBE (COMP) W/CSK HOLE-43 3/4"	73	2265655	DECAL-COVER MAX55/SC	131	2261225	LEADWIRE- BATTERY
■	1378122	PROP KIT (includes 23-26)	74	2260150	POINTER DISC SHORT RED	132	2256300	TIE WRAP-5.5" BLACK
23	2091150	PROPELLER (W.WEDGE)	75	2265800	DECAL-INDICATOR	133	2263201	CLAMP WIRE HARNESS MICRO [2.EA]
24	2151726	WASHER-5/16 STD SS	76	2375400	SHRINK TUBE-1/4OD X 1-3/4" [2.EA]	134	2332103	SCREW-6-20 X 3/8 THD SS
25	2053101	NUT-PROP,NYLOC (MED) 5/16 SS	77	2053414	SCREW-#8-32 X 1/2" TRI-LOBE [3.EA]	135	2260301	CONNECTING WIRE (SWITCH)
26	2092600	PIN-DRIVE (95-4HP'S) SS	78	2267800	GEAR-INDICATOR	136	2260312	WIRE,BLK W/WHT STRP 19 1/2
27	2261722	WASHER FLAT [2.EA]	79	2301310	SCREW-8-18 X 1/2" SS	137	2260322	WIRE,BLK W/BLUE STRP-12"
28	2223100	NUT- TENSION 5/16-18 SS [2. EA]	80	2264015	LIGHT/INDICATOR	138	2256301	TIE WRAP-5.5" WHITE
29	2262605	PIN- BWGRD UPPER THREADED	81	2020713	TERMINAL-ADAPTOR, MAX [2.EA]	139	2266414	BOTTOM PLATE MAX FOOT PED
30	2262607	CLEVIS PIN ZP MAXXUM BWGRD	82	2335400	SHRINK TUBE-1/2 OD X 2" [2.EA]	141	9953104	SCREW-8 X 1/2" SS [8.EA]
31	2260801	SPRING CLIP	83	2052511	CABLE CLAMP, 1/4" VANTAGE	142	2262535	CONTROL BOX-PLASTIC
32	2150400	PULL-GRIP	84	2232360	PULLEY-CABLE DRUM	143	2267800	GEAR-INDICATOR [2.EA]
33	2151700	WASHER-EYE SHAFT(.562 OD)	85	2261730	WASHER-NYLON A/T CON B	144	2262220	INDICATOR-DRIVE
■	2771840	MOUNT- BOW ASSEMBLY, W/BGRD FW STD	87	2996247	TOP BEARING RACE/ PINION DR	145	2261905	BRACKET/INDICATOR
35	2264241	ARM-UPPER FW,STD	88	2223468	SCREW-8-32 X 7/16" ZN PL [4.EA]	146	2301310	SCREW-8-18 X 1/2" SS
36	2293501	BUSHING, STAINLESS STEEL [4.EA]	90	2790002	FOOT PEDAL/PLUG ASSEMBLY (AT)	■	2994830	BAG ASSEMBLY-MAXXUM
37	2263500	BOLT- SHOULDER (MAXXUM) [2.EA]	91	2263700	PUSH-BUTTON FOOT PEDAL	*147	2263431	SCREW 1/4-20 X 3.5" PPH [6.EA]
38	2994307	ARM-LOWER ASSEMBLY,STD,FW,EXT	92	2302732	SPRING-LOWER PEDAL SS	*148	2261713	WASHER-1/4 FLAT SS [6.EA]
39	2263912	MOTOR REST STD MAXXUM	93	2264020	SWITCH MOMENTARY	*149	2263103	NUT-1/4-20 NYLOCK-JAM SS [6.EA]
40	2265514	DECAL-MAXXUM,MOTOR REST [2.EA]	94	2265140	BOOT-MICROSWITCH	■	2991550	CLAMP COLLAR ASSEMBLY
41	2261505	SPACER, MOTOR REST [6.EA]	95	2262114	SCREW-MOUNTING/SWITCH [2.EA]	150	2071550	CLAMP COLLAR "A"
42	2773987	BOWPLATE/INST ASSEMBLY STD FW	96	2233100	NUT-SWITCH MOUNT [2.EA]	151	2071555	CLAMP COLLAR "B"
43	2251601	ROPE (40"), MAXXUM MOUNT	97	2264026	SWITCH-5 SPEED (ALL TERRAIN)	152	2072621	PIN-KNURLED
44	2261708	WASHER-3/8X1/2X.010" SS [2.EA]	98	2261701	LOCKWASHER-STAR	153	2070120	KNOB-CLAMP COLLAR
45	2236000	BEARING NYLINER-[2.EA]	99	2263105	NUT-HEX	154	2073412	SCREW 1/4-28 X 2 3/4" SS
46	2263434	SCREW, 8-18 X 1" PPH SS [2.EA]	100	2261715	SPACER-SWITCH 5 SP MODELS	155	2071718	WASHER #10 NYLON RETAINING
47	2152610	SPRING-PIN LOCKBAR [2.EA]	101	2260170	KNOB-SPEED CONTROL (5 SPD)	156	2071716	WASHER - FLAT SS
48	2233600	LOCK BAR- BOW MOUNT	102	2263000	E-RING TRU-ARC#5133-43	157	2073102	NUT - HEX 1/4 - 28 SS
49	2233602	LOCK BAR, REAR - ZINC	103	2260730	CONNECTOR 1/4 MALE TAB OD	158	2071560	SPLIT COLLAR
50	2152700	SPRING-LOCKBAR CAD.PLTD	105	2332103	SCREW-6-20 X 3/8" THD SS			
51	2262703	SPRING STOP	106	2266413	TENSION SCREW PLATE FTPED			
52	2153602	EYE SHAFT-LOCKBAR STD-PL	107	2260511	PIN-PIVOT A/T FT PDL			

\*\*Seal & Oring Kit P/N 2888460

\* This item is part of an assembly. This item cannot be sold separately due to machining and /or assembly that is required.

P/N 2264956 REV.A 8-01

