

**MAXXUM 74 & SONAR**  
74 LBS THRUST  
24 VOLT 45 AMPS  
42" OR 36" SHAFT

for use with motors with serial numbers beginning MKAE  
3-year warranty from the date of purchase

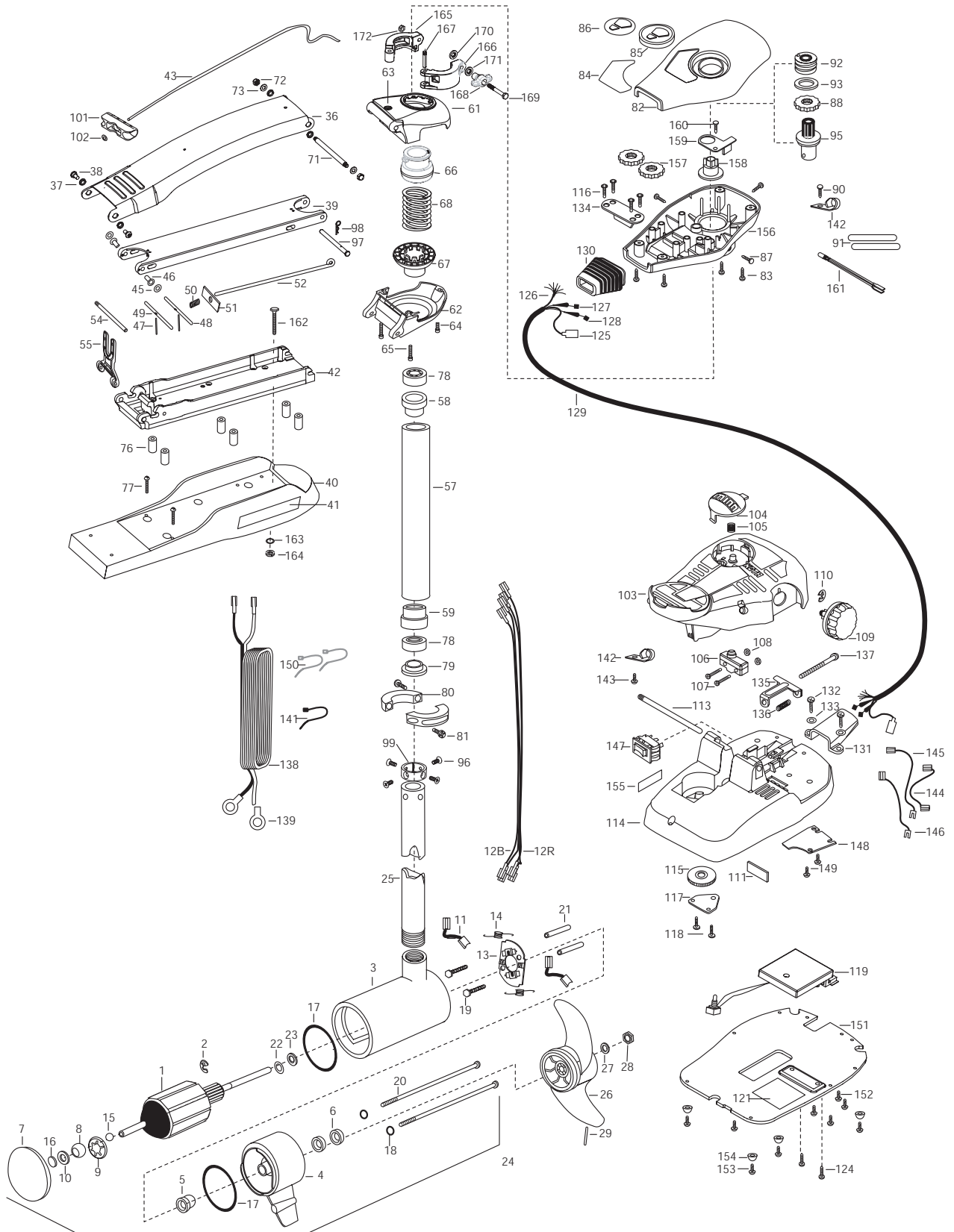

1	2-100-103	ARMATURE ASSEMBLY 24V 4"	57	2272069	TUBE -OUTER 21" 4 HOLES [FOR 42"]	119	2264038	CONTROL BOARD ASSEMBLY 24V MAX
2	788-040	RETAINING RING		2272066	TUBE -OUTER 18" 4 HOLES [FOR 36"]	121	2365107	INSULATING PAD 2.3 X 3.2
3	2-200-160	HOUSING ASSEMBLY CENTER 4.0	58	2266260	BEARING RACE-(565T)	124	2263448	SCREW, 8-32 X 1 [2.EA]
	92-200-170	HOUSING ASSEMBLY CENTER 4.0- SONAR	59	2266220	BEARING RACE-STEEL	125	2211400	EXTENSION CABLE- SONAR
4	2-300-160	BRUSH END HOUSING ASSEMBLY	■	2991893	BOWGUARD ASSEMBLY-FT CTRL,MAX	126	2261219	WIRE HARNESS AT & MAX 82.5
5	144-017	BEARING- FLANGE (SERVICE ONLY)	61	2772315	BRACKET BASE TOP/EYELETASSEMBLY	127	2267500	CABLE ASSEMBLY-RIGHT 5'
6	880-025	**SEAL [2.EA]	62	2991999	BRKT BOTTOM/BEARING FW ASSEMBLY	128	2267510	CABLE ASSEMBLY-LEFT 5'
7	92-400-172	PLAIN END HOUSING ASSEMBLY- SONAR	63	2262315	EYELET KIT -ROPE	129	2265430	CABLE JACKET 5'
	2-400-160	PLAIN END HOUSING ASSEMBLY	64	2263402	SCREW 1/4-20 X 3/4 ZINC	130	2265110	BOOT-CONTROL BOX
8	144-021	BEARING SPHERICAL	65	2263404	SCREW-1/4-20X2-1/4 SHCP [2.EA]	131	2265115	BOOT-FOOT PEDAL BASE
9	784-025	BEARING RETAINER	66	2071541	SPRING-SLEEVE UPPER	132	2372100	SCREW-8-18 X 5/8 THD SS [2.EA]
10	991-040	WASHER- FELT	67	2071535	SPRING SLEEVE, LOWER	133	2261714	WASHER-MAXXUM PT PDL [2.EA]
11	186-094	BRUSH [2.EA]	68	2262712	SPRING, BOWGUARD, NIK PL	134	2261901	BRACKET-CONDUIT AT/MAX
12B	640-013	BRUSH LEAD BLK 10 AWG 51-1/2	71	2262605	PIN- THREADED	135	2263210	BRACKET-CONDUIT ADJUSTMENT
12R	640-117	BRUSH LEAD RED 10 AWG 53	72	2223100	NUT- NYLOC [2.EA]	136	2262720	SPRING-CONDUIT
13	738-004	BRUSH PLATE 4"	73	2261722	WASHER [2.EA]	137	2263463	SCREW-1/4-20 X 2 STL PPH
14	975-041	SPRING- TORSION [2.EA]	■	2994832	BAG ASSEMBLY	138	2261227	LEADWIRE VARIABLE
15	116-025	BALL- STEEL	*76	2261505	SPACER, MOTOR REST [6.EA]	139	2020700	TERMINAL RING, 3/8 [2.EA]
16	303-043	THRUST DISC	*77	2263434	SCREW, 8-18 X 1 PPH SS [2.EA]	141	2256300	TIE WRAP-5.5 BLACK
17	701-043	**O-RING [2.EA]	78	2266000	BEARING BALL-STEEL	142	2263201	CLAMP WIRE HARNESS MICRO [2.EA]
18	701-009	**O-RING —THRU BOLT [2.EA]	79	2266115	BEARING CONE	143	2332103	SCREW-6-20 X 3/8 THD SS
19	830-027	SCREW -SELF THREAD 10-32X2 [2.EA]	80	2771617	COLLAR HALF-ZINC-2 PER- KIT	144	2260316	CONNECTING WIRE VAR.SPD
20	830-094	THRU BOLT 12-24X10.31 [2.EA]	81	2263452	SCREW-1/4-20 X 3/4 SHCS SS [2.EA]	145	2260312	WIRE,BLK W/WHT STRP 19 1/2
21	973-025	SPACER- BRUSH PLATE [2.EA]	82	2260283	CONTROL BOX COVER-MAXXUM	146	2260323	WIRE,BLK W/GRN STP VARIAB
22	990-051	WASHER- STEEL	83	2372100	SCREW-8-18 X 5/8 THD [4.EA]	147	2254031	SWITCH-MOM/OFF/COM
23	990-052	WASHER- NYLATRON	84	2265532	DECAL COVER, MAXXUM 74	148	2266412	SWITCH PLATE, PT PEDAL
24	2317036	MOTOR ASSEMBLY 24V 4" VARS	85	2260150	POINTER DISC TRNSLCNT RED	149	2332103	SCREW-6-20 X 3/8 THD SS [2.EA]
	2327032	MOTOR ASSEMBLY 24V 4" VARS- SONAR	86	2265800	DECAL-INDICATOR	150	2256301	TIE WRAP-5.5 WHITE [2.EA]
25	2032003	TUBE COMP W/CSK HOLE 43-3/4	87	2053414	SCREW-#8-32 X 1/2 TRI-LOBE [3.EA]	151	2264511	BOTTOM PLATE, MAXXUM PT
	2032001	TUBE COMP W/CSK HOLE 36"	88	2267800	GEAR-INDICATOR	152	9953104	SCREW-8 X 1/2 PPH SS [5.EA]
■	1378129	PROPELLER KIT (includes 26-29)	90	2301310	SCREW-8-18 X 1/2 SS	153	2263455	SCREW #12 [4.EA]
26	2331120	PROPELLER W.WEDGE HP&RT	91	2355410	SHRINK TUBE-3/8 OD X 2- [2.EA]	154	2265126	BUMPER [4.EA]
27	2091701	WASHER-PROP LARGE	92	2232360	PULLEY-CABLE DRUM	155	2266610	DECAL-ON/OFF SWITCH
28	2093101	NUT-PROP NYLOCK SS	93	2261730	WASHER-NYLON	156	2262535	CONTROL BOX-PLASTIC AT'S
29	2092600	PIN-DRIVE SS	95	2996247	PINION/RACE ASSEMBLY	157	2267800	GEAR-INDICATOR [2.EA]
■	2771840	MOUNT,BOW ASSEMBLY, FW STD W/BG	96	2223468	SCREW-8-32 X 7/16 ZN PL [4.EA]	158	2262220	INDICATOR-DRIVE
36	2264241	ARM UPPER-FW STD	97	2262607	PIN- CLEVIS ZN	159	2261905	BRACKET/INDICATOR
37	2293501	BUSHING, STAINLESS STEEL [4.EA]	98	2260801	SPRING CLIP ZN	160	2301310	SCREW-8-18 X 1/2 SS
38	2263500	BOLT, SHOULDER MAXXUM [2.EA]	99	2071560	SPLIT COLLAR	161	2264015	LIGHT/INDICATOR
39	2774315	ARM-LOWER ASSEMBLY,STD,FW,EXT	101	2150400	PULL-GRIP	■	2994830	BAG ASSEMBLY-MAXXUM
40	2263912	MOTOR REST STD MAXXUM	102	2151700	WASHER-EYE SHAFT .562 OD	*162	2263431	SCREW 1/4-20 X 3.5 PPH [6.EA]
41	2265514	DECAL-MAXXUM,MOTOR REST [2.EA]	103	2790002	FOOT PEDAL/PLUG ASSEMBLY	*163	2261713	WASHER-1/4 FLAT S/S [6.EA]
42	2773987	BOWPLATE- FW STD MACH/INSERT	104	2263700	PUSH-BUTTON FOOT PEDAL	*164	2263103	NUT-1/4-20 NYLOCK-JAM [6.EA]
43	2251601	ROPE 40" MAXXUM MOUNT	105	2302732	SPRING-LOWER PEDAL SS	■	2991550	CLAMP COLLAR ASSEMBLY
45	2261708	WASHER-3/8X1/2X.016 [2.EA]	106	2264023	SWITCH-SEALED ASSEMBLY	165	2071550	CLAMP COLLAR "A"
46	2236000	BEARING NYLINER- [2.EA]	107	2262114	SCREW-MOUNTING/SWITCH [2.EA]	166	2071555	CLAMP COLLAR "B"
47	2152610	SPRING-PIN LOCKBAR [2.EA]	108	2233100	NUT-SWITCH MOUNT [2.EA]	167	2072621	PIN-KNURLED
48	2233600	LOCK BAR- BOW MOUNT	109	2260160	KNOB-SPEED CONTROL VAR	168	2070120	KNOB-CLAMP COLLAR
49	2233602	LOCK BAR- REAR ZINC	110	2263000	E-RING TRU-ARC#5133-43	169	2073412	SCREW 1/4-28 X 2 3/4" SS
50	2152700	SPRING-LOCKBAR CAD.PLT	*111	2266413	PLATE -TENSION SCREW FTPED.	170	2071718	WASHER #10 NYLON RETAINING
51	2262703	SPRING STOP	113	2260511	PIN-PIVOT A/T PT PDL	171	2071716	WASHER - FLAT SS
52	2153602	EYE SHAFT-2LOCKBAR STD-PLTD	114	2774550	FT PEDAL BASE/PIN ASSEMBLY	172	2073102	NUT - HEX 1/4 - 28 SS
54	2260506	HINGE-PIN HEADLESS ZINC	115	2262301	PULLEY- FOOT PEDAL			
55	2293811	YOKE,MAX MNT-POLYPROPYLENE	116	2223430	SCREW- 8X3/4 PPH TYPE 25 SS [4.EA]			
■	2772012	TUBE W/BEARING RACE ASSEMBLY 42"	117	2266400	COVER-PULLEY STAMPING			
	2772015	TUBE W/BEARING RACE ASSEMBLY 36"	118	2301310	SCREW-8-18 X 1/2 SS [2.EA]			

**\*\*Seal & Oring Kit P/N 2889460**

\* This item is part of an assembly. This item cannot be sold separately due to machining and /or assembly that is required.

P/N 2264945 REV.G

12-03

